



FIDESYS

strength analysis system

Version 2.1

User Guide



Contents	
Introduction	8
At a glance	8
Getting Started	9
System requirements.....	9
Hardware requirements	9
Operating system.....	9
Installation	10
Microsoft Windows	10
Linux	12
Activation and trial period.....	13
Trial period.....	13
Activation.....	14
Information on the purchased license	14
Removing the software.....	14
Overview.....	15
Package structure	15
Running the software.....	15
Main Window	15
Software history	17
Version 2.0	17
Version 1.7.1.....	17
Version 1.7.0.....	18
Version 1.6 R2	19
Version 1.6	19
Version 1.5 R2	20
Version 1.5	20
Version 1.4	21
Version 1.3.....	21
Version 1.2	21
Version 1.1.....	21
Using the Program	22
Geometry.....	22
Geometry import	22
Geometry creating	23
Meshing.....	23
Volume meshing	24



Surface mesh generation	24
Setting material and element type.....	25
Element types	25
Set the Material	25
Setting tabular dependencies for materials.....	27
Import/Export Material.....	28
Setting the yielding model	29
Von Mises yield criterion	29
Drucker-Prager yield criterion	31
Polylinear hardening	33
Element types	34
Blocks operations.....	34
Setting shell properties.....	37
Setting beam properties	38
Specifying Sphere element properties	39
Set spring properties.....	39
Setting boundary conditions.....	40
Types of boundary conditions	40
Setting initial conditions	41
Types of initial conditions.....	41
Time/coordinate dependency	41
Setting contact interaction	44
Contact region	44
Autoselection of contact	45
Contact algorithm.....	48
Elements Type	48
Contact status.....	48
Starting calculation.....	49
Analysis types	49
Types of analysis.....	50
Multistep solution	51
Setting steps for boundary conditions.....	51
Setting steps for blocks (volumes).....	53
Spectral element method	55
SEM brief description and advantages	55
SEM Usage.....	57
Parallel calculations on several computers using MPI technology	58



MPI brief description and advantages	58
MPI implementation in Fidesys	58
MPI installation	58
MPI local usage	59
MPI usage on several nodes	59
Requirements for the correct operation	59
MPI setting on several nodes.....	59
Registration before the first usage	61
Overview of the calculation results.....	61
Calculation example using MPI.....	62
Heterogeneous materials effective property calculation	62
Geometry of the model for effective property calculation.....	62
Starting calculation	64
Element types	64
Effective property calculation and its results	64
SEG-Y format.....	66
Results Visualization and Postprocessing	70
Fidesys Viewer at a glance	70
Main Window	70
Basics of the program	71
Display on the data field and legend model.....	71
Selection	71
On-screen information display	71
Overview of the strained model	71
Spherical/cylindrical coordinate systems.....	71
Graphing along straight line	71
Graphing along curves.....	72
Graphing in time dependency	72
Estimation of the mesh quality.....	72
Slice	72
Cross section	72
Beam and shell 3D-display	72
Margin of Safety.....	72
Harmonic analysis	73
Data saving	73
Step-by-Step User Guide	74
Static analysis (3D).....	74



Geometry creation	75
Meshing	77
Setting boundary conditions	80
Setting material and element type	83
Starting calculation	86
Results analysis	86
Using Console Interface	88
Static load (gravity force).....	90
Geometry creation	91
Meshing	93
Setting boundary conditions	94
Setting material and element type	95
Starting calculation	97
Results analysis	97
Using Console Interface	99
Static load (beam model, reaction forces).....	100
Geometry creation	100
Meshing	101
Setting boundary conditions	102
Setting material and element type	103
Setting beam cross section profile	106
Starting calculation	106
Results analysis	107
Using Console Interface	108
Static load (shell)	109
Geometry creation	110
Meshing	110
Setting boundary conditions	111
Setting material and element type	112
Starting calculation	115
Results analysis	116
Using Console Interface	119
Hydrostatic pressure on cylinder (setting boundary conditions according to coordinates).....	120
Geometry creation	120
Meshing	125
Setting material and element type	126
Setting boundary conditions	129



Starting calculation	132
Results analysis	133
Using Console Interface	135
Buckling (shell model).....	136
Geometry creation	136
Meshing	140
Setting boundary conditions	142
Setting material and element type.....	142
Setting shell thickness.....	145
Starting calculation	146
Results analysis	146
Using Console Interface	151
Modal analysis (3D).....	152
Geometry creation	153
Meshing	153
Setting boundary conditions	154
Setting material and element type.....	155
Starting calculation	157
Results analysis	158
Using Console Interface	160
Modal analysis (shell model)	161
Geometry creation	161
Meshing	162
Setting boundary conditions	163
Setting material and element type.....	164
Setting shell thickness.....	166
Starting calculation	167
Results analysis	167
Using Console Interface	169
Setting heat transfer (3D, working with two blocks).....	170
Geometry creation	171
Meshing	173
Setting material and element type.....	174
Setting boundary conditions	177
Starting calculation	179
Results analysis	179
Using Console Interface	181



Dynamic load: nonsteady heat transfer (3D, implicit scheme).....	182
Geometry creation	182
Meshing	183
Setting material and element type.....	184
Setting boundary conditions	186
Setting time dependency of boundary conditions	186
Starting calculation	188
Results analysis	188
Using Console Interface	192
Harmonic analysis (beam model)	193
Geometry creating	193
Meshing	196
Specifying the material and type of element.....	196
Beam section setting.....	198
Setting boundary conditions	199
Run calculation.....	201
Results analysis	202
Using the console interface	205
Bounded Contact Simulation	206
Geometry creation	207
Meshing	207
Specifying the material and type of element.....	210
Setting boundary conditions	212
Run calculation.....	214
Results analysis	215
Using the console interface	216
Change of pressure in well	217
Geometry creating	217
Meshing	220
Specifying the material and type of element.....	225
Setting boundary conditions	228
Run the calculation.....	232
Results analysis	233
Estimate the safety margin	235
Using the console interface	236
The loading history of the elastic-plastic plate	238
Geometry creating	238



Meshing	239
Specifying the material and element type	240
Setting boundary conditions	241
Set the dependence of the BC on the time and / or coordinates	242
Run calculation.....	244
Results analysis	244
Using the console interface	245
Sequential addition of volumes in the calculation process	247
Geometry creating	247
Meshing	249
Specifying the material and type of element.....	249
Setting boundary conditions	251
Run calculation.....	252
Result Analysis	254
Using the console interface	255
Sequential deletion of volumes in the calculation process.....	256
Geometry creating	257
Meshing	260
Set the Material	262
Setting boundary conditions	263
Set the material and element type	264
Run calculation.....	266
Result Analysis	267
Using the console interface	269
Seismic wave propagation (SEG-Y results).....	270
Geometry creating	270
Meshing	274
Specifying the material and type of item.....	274
Setting boundary conditions	276
Set the BC dependency on time and / or coordinates	277
Receivers.....	278
Run calculation.....	279
Results analysis	280
Using the console interface	282
Contacts.....	283



Introduction

At a glance

CAE Fidesys is a software package for strength analysis. The package comprises the following types of analysis:

- Static
- Dynamic (transient)
- Buckling
- Modal
- Harmonic;
- Effective properties.

The package also includes a program **Fidesys Viewer** for visualization and analysis of the obtained results:

- Visualization of scalar and vector fields
- SEG-Y files visualization
- Graph
- Plotting dependencies of functions on frequency;
- Time dependency analysis.



Getting Started

System requirements

CAE Fidesys from the beginning has been designed in such a way that the system requirements of the package are low: it can be run on an ordinary personal computer. If the computer has one or more multi-core processors calculations will be automatically parallelized on all cores. Starting version 1.5, calculation parallelization to several nodes connected to a local network or a cluster are available in the 64-bit version of the program package.

CAE Fidesys software package has the following minimal requirements for software and hardware.

Hardware requirements

- CPU: Dual-core 1,7 GHz minimum
- RAM: 4GB minimum
- Free hard drive space: 5 GB
- Video card NVIDIA GeForce GTX 460 or faster
- Screen resolution: 1024x768 or higher

Operating system

The following Windows versions 64-bit are supported:

- Windows 7 Service Pack 1;
- Windows 8;
- Windows 8.1;
- Windows Server 2008 R2 SP1;
- Windows Server 2008 Service Pack 2;
- Windows Server 2012;
- Windows Server 2012 R2;
- Windows 10 ;
- Ubuntu 18.04
- CentOS 6;
- CentOS 7;
- Debian 9;
- RedHat 6;
- RedHat 7;
- Open SUSE Leap 15
- Alt Linux 7
- Alt Linux 8

Installation

Microsoft Windows

The user installing the software on a computer must have administrator rights on that PC. Please, close all the **CAE Fidesys** windows before installation if there's another version of **CAE Fidesys** installed.

1. Download the **CAE Fidesys** installer from the site <http://www.cae-fidesys.com/ru/download/login> and run it for the architecture you are interested in (Windows x64 or Windows x32), or run the installation from the DVD-ROM.

If any other version of CAE Fidesys is already installed on a computer, it will be suggested to remove it or to cancel the installation while starting the installation program.

2. Click **Next** in a pop-up window.

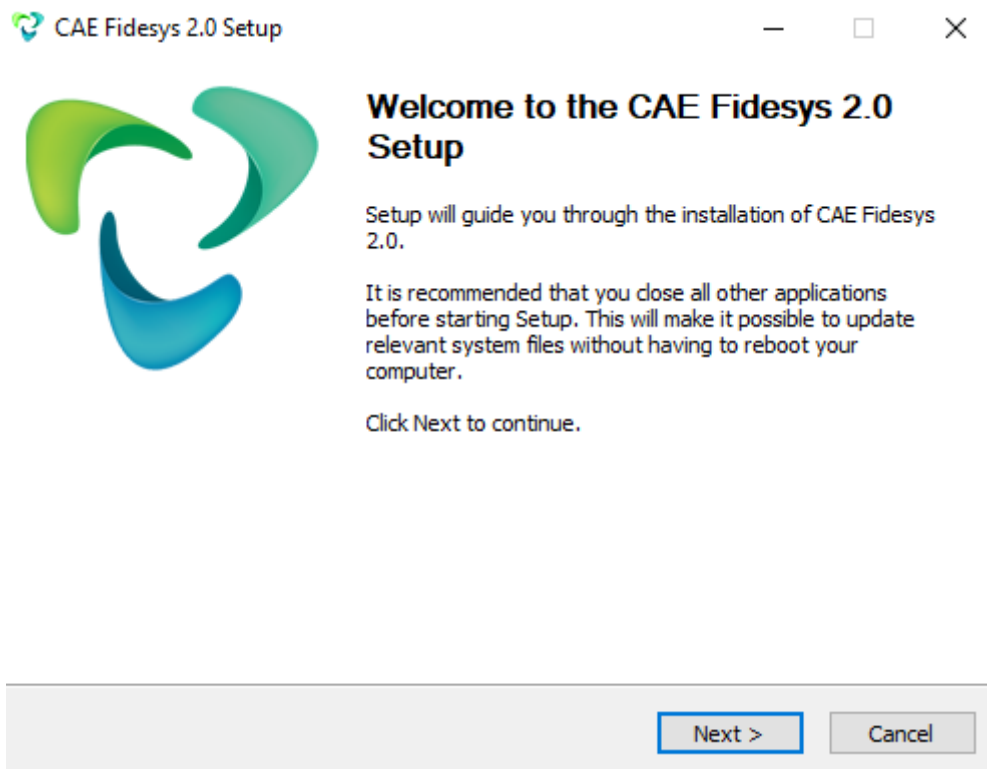

3. Please, read the license agreement. If you do not agree with any of its paragraphs, interrupt the installer by clicking **Cancel**. If you totally agree with its terms, click **Agree** to proceed the installation.

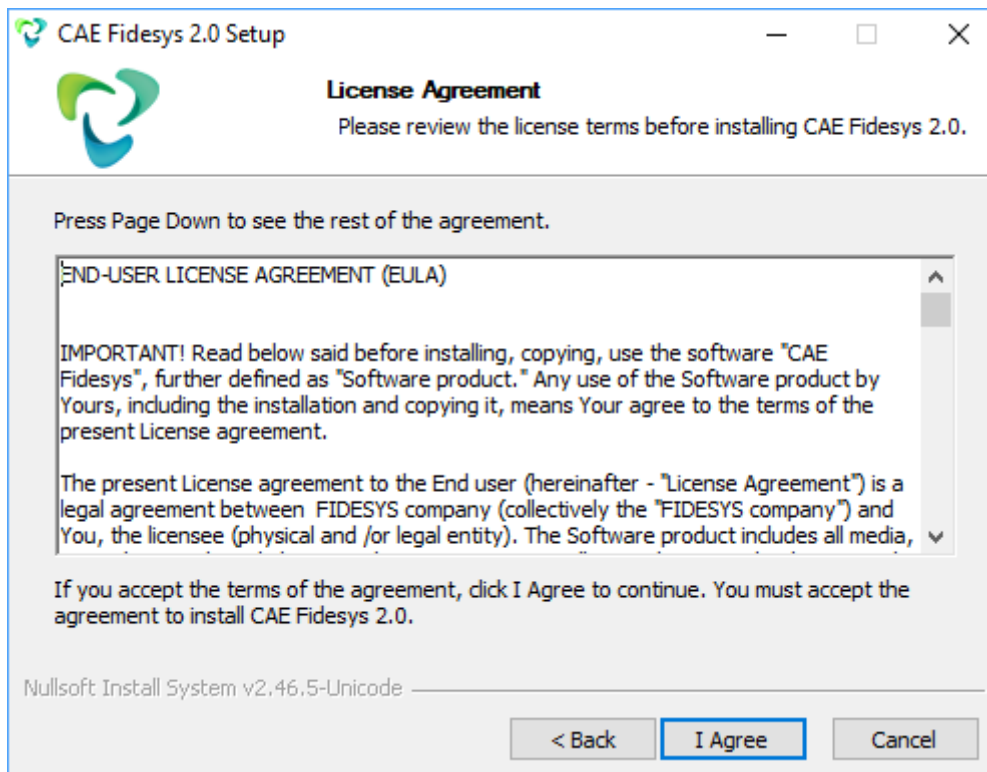

4. Select a folder for installation and click **Next**.

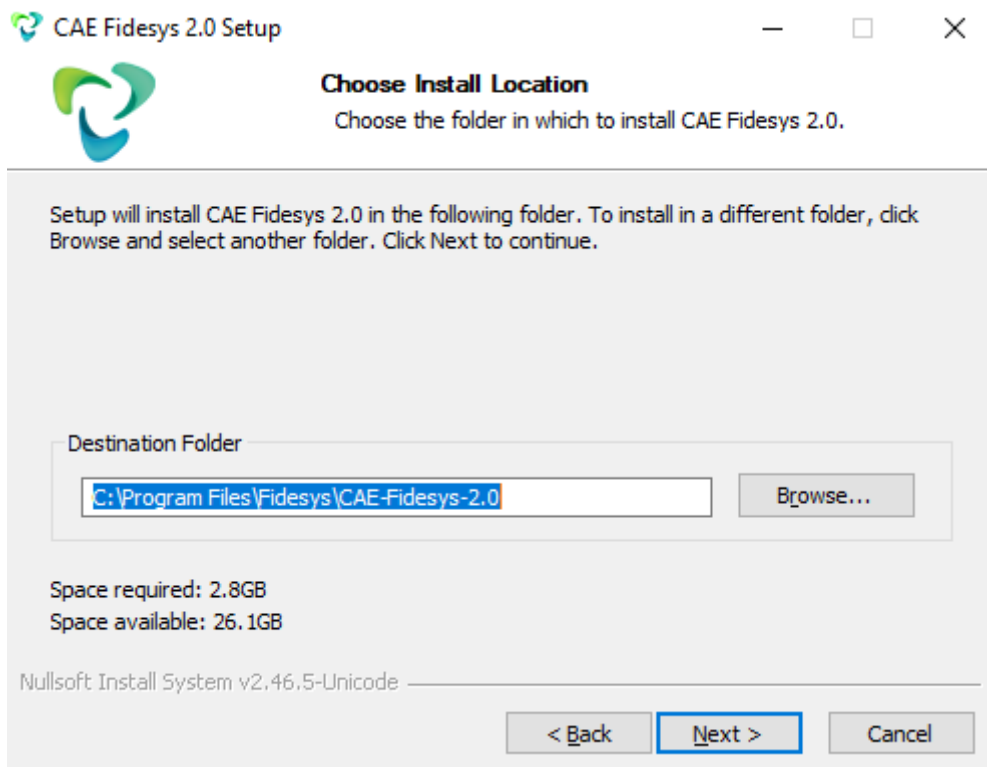

5. In the Start menu enter the name of the folder where a shortcut for running the program will be created. If you do not want to create a folder in the Start menu, choose **Do not create shortcuts**. Click **Install**.

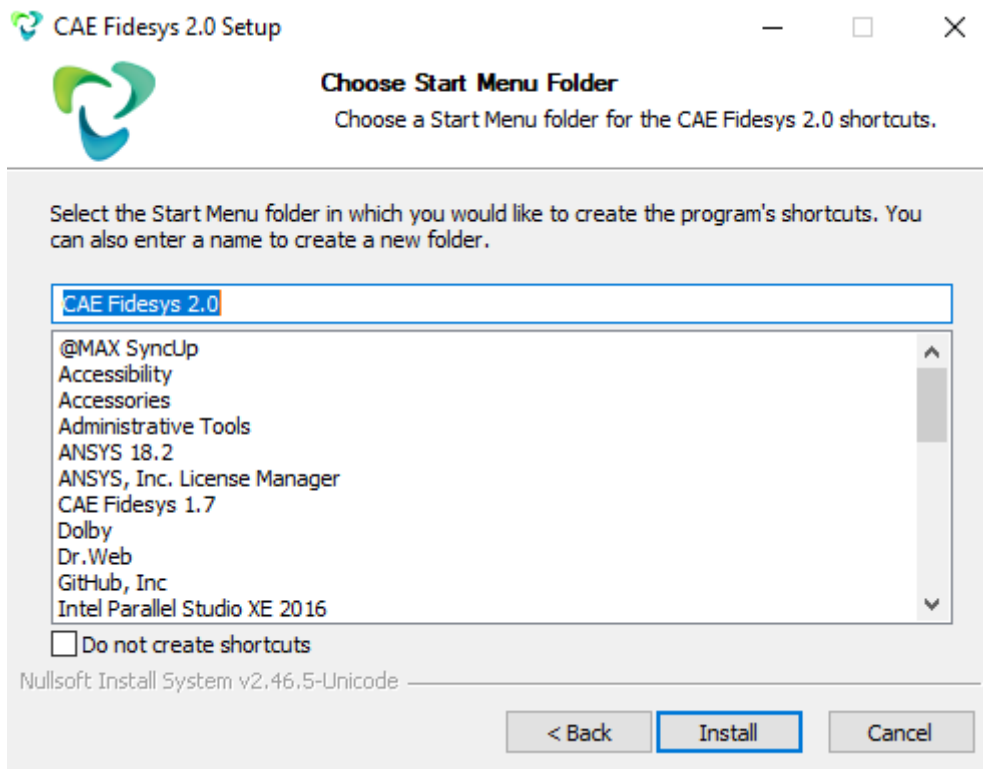

6. The process of installation may take some time. Click **Ready** after installing.

Linux

Only 64-bit Linux distribution kits are currently supported.

1. Please, download the **CAE Fidesys** file for Linux x64 from <http://www.cae-fidesys.com/ru/download/login>.
2. Right-click on the downloaded file and select **Properties** item from the contextual menu.
3. In the opened window, go to the tab **Permissions** and tick **Allow executing file as program**. Click **Close**.

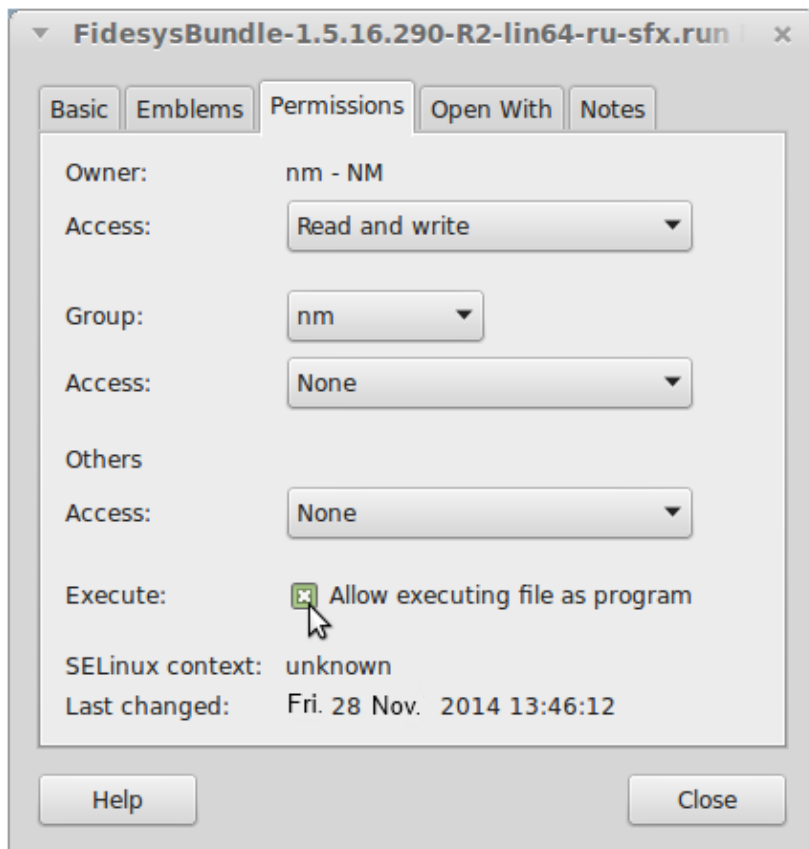

4. Run the installer by double-clicking on the installer file. When the dialog box appears, click **Run in Terminal** button:

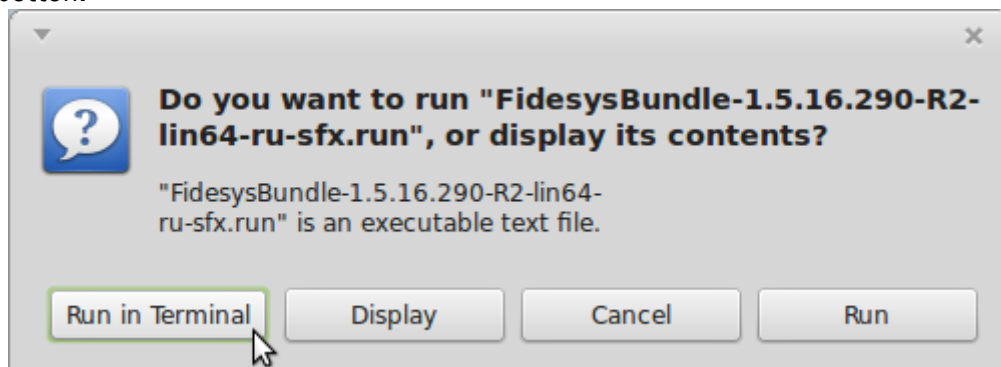

Activation and trial period

When you first run the preprocessor, the *Fidesys Licensing* window appears with a proposal to purchase a license or to activate a trial period.

Trial period

30-day trial period activates automatically on package installation. The trial period starts at the moment when application installation is completed. The trial period is intended for familiarization with the product and is not for any commercial calculations (related directly or indirectly to getting a profit out of them). The trial period can not be activated on a virtual machine, and a trial version is not dedicated to work with via remote desktop.

To activate a trial period, click the button **Trial period** in the start window.

As long as the program is running in trial mode, the *Fidesys Licensing* window will appear each time you launch it. Please, press the button **Try** to continue working in a trial mode.

Activation

To activate the product:

1. Press the button **Activate** in the *Fidesys Licensing* window.
2. Select **I do not have a V2C file** and click **Generate C2V**. Save File dialog window will be opened. Save the C2V file and send it to the organization where the product was purchased.
3. In response, you will get a file containing an activation key with V2C extension. Having received the V2C file, select **I have V2C file** and click **Apply V2C**. You will see an Open File dialog window. Specify a path to the received V2C file.

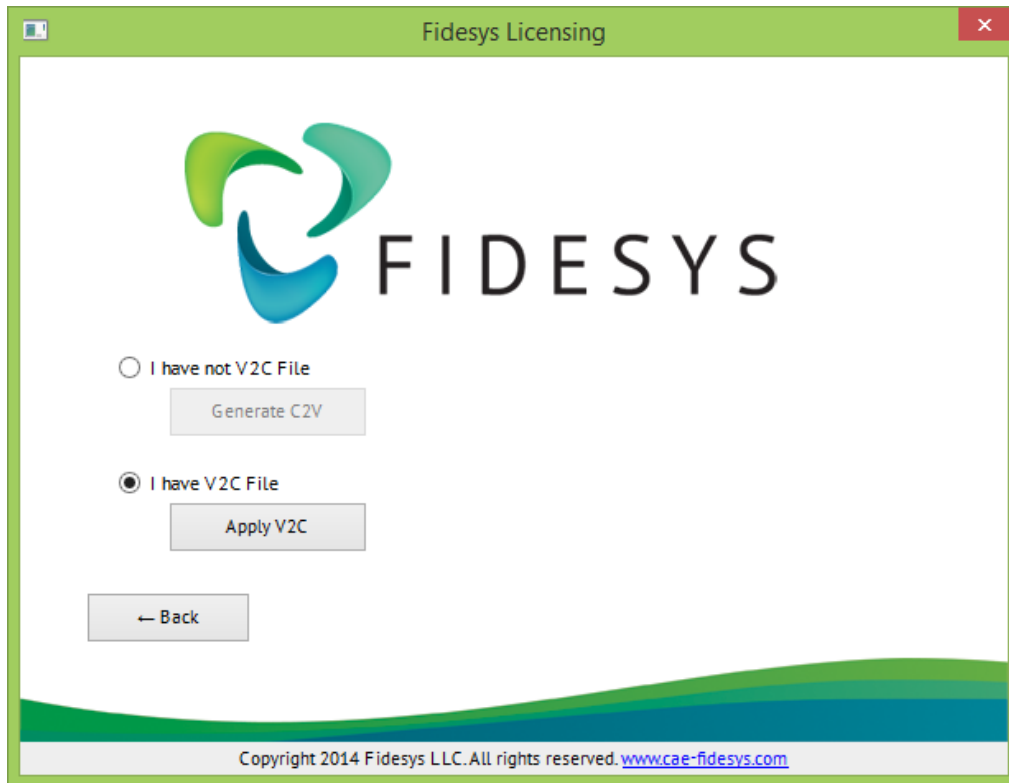

4. Your product is activated.
Activation will performed automatically while using dongle.

Information on the purchased license

On selecting **Help** → **About** in the Main Menu, you will see a window with the following information:

- The full software version number;
- License type and its expiration date;
- The list of features available in the purchased license.

Removing the software

The user removing the software must have administrator rights.

Please, finish all the running copies of the application before removing the software: both preprocessor (*Fidesys*) and postprocessor (*Fidesys Viewer*).

To remove the software, open Windows Control Panel and select **Programs and Features (Add or Remove Programs** in the earlier versions of Windows). Select *CAE Fidesys #.#.#.# xNN* in the list of installed programs, where #.#.#.# are the four numbers standing for the number of the version and xNN is the architecture (x64). Right-click it and choose **Delete/Change**. Confirm your choice by clicking **Delete** in the opened window.

Removing the software does not involve removing its activation data.

Overview

Package structure

CAE Fidesys comprises two main components:

- **Fidesys** — preprocessing and analysis (computational kernels).
- **FidesysCalc** – calculations;
- **Fidesys Viewer** — postprocessing and visualization of results.

Running the software

You can run the program in either of the following ways:

- Using the Start menu (if you chose creating shortcuts in it when installing): choose **Fidesys** in the folder where you installed the program.
- Using any file manager for Windows from the list where the program was installed (C:\Program Files\Fidesys\Fidesys 2.0 by default): run the file **fidesys.exe** (it is in the folder **preprocessor\bin**).

Several copies of the program can be run on the same PC at a time.

If the license fee for the program is activated, after running the program you see its Main window. If the trial period is activated, a **Fidesys Licensing** window appears in which you should either click the button **Activate** in order to purchase a license or click **Try** to continue working in trial mode and go to the Main window.

Main Window

CAE Fidesys has an intuitive graphic interface providing communication between the user and the software, and it allows the user to perform the full cycle of calculations step-by-step.

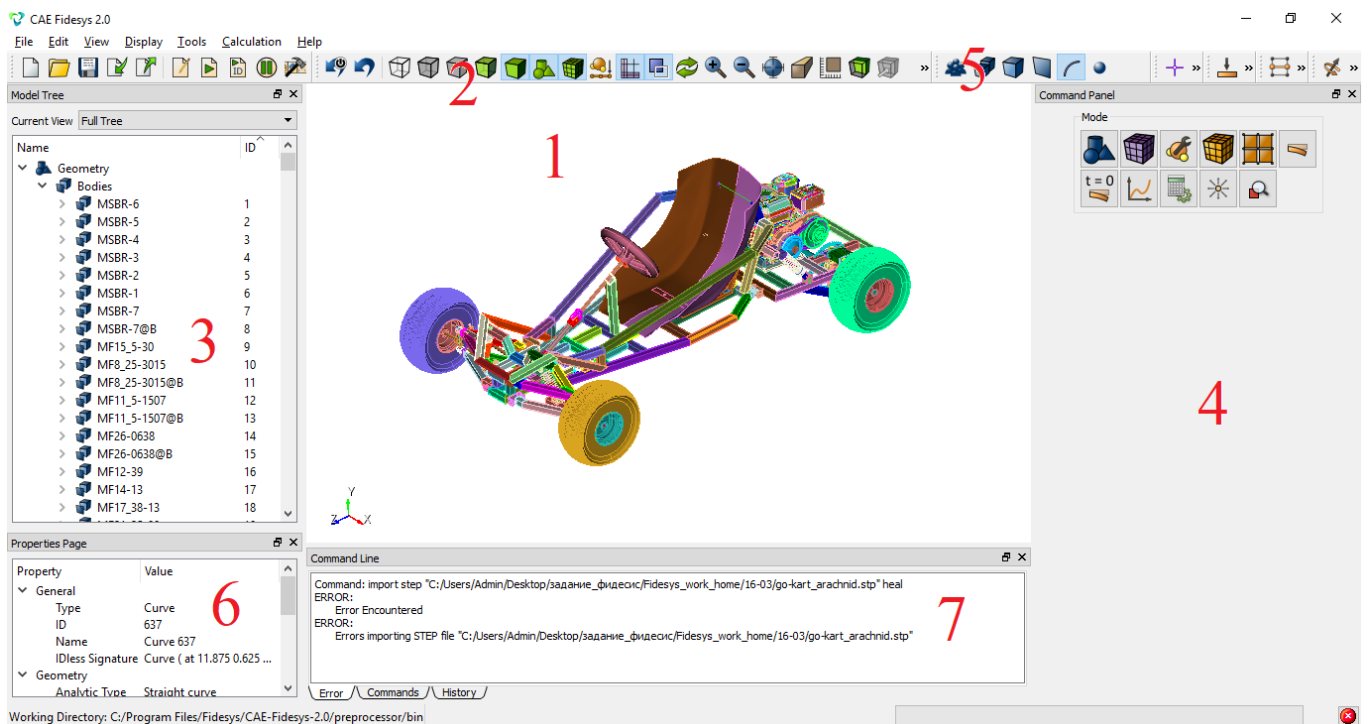



Workbench (1) displays the model and visual effects.

Main Menu (2) includes standard operations for working with files and projects, managing the visualization modes, panel display settings, help, and other functionality available in the drop-down lists of the menu.

Power Tools (3) comprise the Model Tree, as well as the tools for geometry and mesh analysis.

Command Panel (4) contains most of commands for working with the program. Panel display buttons are logically located, and it allows the user to perform the full cycle of calculations step-by-step.

Toolbar (5) comprises the buttons for calling the most frequently used commands while working with the program.

Properties Page (6) displays the properties of the selected object in the Workbench or in the Model Tree.

Console (7) is used for the input of commands of *CAE Fidesys* and for the output of the messages for the user.

Software history

Version 2.1

Released: June 2019

- Working with geometric models consisting of a large number of elements has accelerated. In particular, the loading and preprocessing time for such models has been reduced.
- Added automatic recording of the results of dynamic calculations (displacements, velocity, pressure, principal stresses) in SEG-Y files for beam and shell elements.

Version 2.0

Released: February 2019

Added calculation of multi-step loading

- Available setting of active boundary conditions for each loading step (adding / removing BC in steps);
- Available setting of the boundary conditions for each loading step in the form of a table dependence (change of BC on the steps);
- Available setting of active blocks in the model for each loading step (adding / deleting blocks in steps).

Recording and reading a file in SEG-Y format

- Added automatic recording of the results of dynamic calculations (displacements, velocity, pressure, principal stresses) in SEG-Y files for required receiver lines;
- The ability to open and analyze SEG-Y files has been added to *FidesysViewer*.

Additions and improvements in the preprocessor

- Added support for formula and table dependencies for material constants in import and export of materials;
- Added drawing graphs for table dependencies;
- The ability to create models in the preprocessor is enabled regardless of the type of license key. For example, you can create a model for non-linear calculation, having only a key for the Standard version and then calculate on the workstation where the key for the Professional version is available.

Version 1.7.1

Released: September 2018

New types of boundary conditions

- bonded contact (the ability to solve large assemblies on nonconformal mesh of different order);
- radiation;
- heat source;
- volume heat source;
- pore pressure;
- fluid flow;
- source of fluid;
- volume source of fluid.

New types of analysis

- pore fluid transfer;
- calculation of effective coefficients of thermal expansion.

Added ability to set initial conditions



- initial displacement;
- initial speed;
- initial angular velocity;
- initial temperature;
- initial pore pressure.

New material properties

- multilinear hardening (Mises);
- prestress;
- piezoelectricity.

Additions and improvements in the preprocessor

- a new smart method for setting materials.

Additions and improvements in the postprocessor

- improved software interface.

Version 1.7.0

Released: August 2017

New element types

- springs;
- sphere element;
- beam elements of the second order (with intermediate nodes).

New types of boundary conditions

- distributed force;
- rigid coupling;
- gravity;
- angular velocity;
- non-reflective boundary conditions and initial conditions in dynamic analysis.

New types of analysis

- harmonic analysis;
- method of superposition of modal forms, including the setting of damping parameters, for solving dynamic problems.

Added the ability to set dependencies of material parameters on coordinates / temperature.

Added the ability to calculate the effective masses and coefficients of participation of own forms of the structure.

For beam elements added new section profiles.

Improved operation of the generator of unstructured settlement mesh, including the case of hybrid mesh.

Added support for CATIA v5, v6 formats.

Additions and improvements in the preprocessor

- Improved stability.



Additions and improvements in the processor (calculation module)

- Elastoplastic deformation according to the Drucker-Prager model;
- Harmonic analysis;
- Ability to simulate couplings.

Additions and improvements in the postprocessor (3D-visualization module)

- Improved operation of the software interface based on Python Shell.

Version 1.6 R2

Released: April, 2015

Updates and improvements in the preprocessor

- The possibility to automatically process the calculation results of composites effective properties;
- The stability of the operations is increased.

Updates and improvements in the processor

- Elastoplastic deformation by the Drucker-Prager model;
- Calculation of the effective properties of composite materials;
- HPC and Dynamics modules are available in Standard and Professional.

Updates and improvements in the postprocessor (3D-visualization module)

- Programming interface operation based on Python Shell is improved.

Version 1.6

Released: February, 2015

- The support for importing geometry in the following CAD-formats is added:
 - SolidWorks;
 - Parasolid;
 - Pro/Engineer.
- The support of APREPRO (An Algebraic Preprocessor for Parameterizing Finite Element Analyses) is added
- New profiles of beam cross section are added:
 - Channel (C-shape);
 - Corner (L-shape);
 - Taurus (T-shape);
 - Z-shape;
 - Hollow rectangle.
- The possibility to set the boundary conditions using tabular and formular dependency on the coordinates and temperature for static analysis is added;
- The new generator of adaptive tetrahedral meshes is added;
- In accordance with the users wishes, the panel of nonlinear solver settings is changed;
- Contact problems in 3D and 2;
- Contact surface binding in 3D and the contact curves binding in 2D;
- Modal analysis for prestressed bodies;
- The automatic adaptive calculation of the loading steps size is added;



- The output of intermediate results and calculation log (textual information on the status of the calculation by stages) are added for nonlinear problems;
- Thermoelastic problems for 2nd order shell elements: TRISHELL6, SHELL8, SHELL9;
- The support for multiprocessor calculations based on MPI technology for the following calculations is added:
 - Spectral element method;
 - Plasticity for small and finite deformations;
 - Dynamic analysis for the explicit and implicit time schemes.
- The incorporation of plastic deformation using finite element method and spectral element method is modified taking into account:
 - Finite deformations;
 - Thermoelasticity.
- Dynamic analysis performance is improved;
- Performance of spectral element method on hybrid meshes in buckling problems is improved;
- The solution tolerance of static problem with shear loading using 4-node plane and 8-node volumetric elements is increased;
- Fidesys Viewer 1.6: focusing of model elements in the current position of the mouse pointer is added;
- Fidesys Viewer 1.6: strength analysis filter operation is improved;
- Fidesys Viewer 1.6: operation of the “Agreed resultants” filter for shell structures is improved;
- The compatibility with Windows 8 and Windows 8.1 is improved;
- The Progress Bar operation is improved;
- The CAE Fidesys licensing system is added.

Version 1.5 R2

Released: July, 2014

- The ability to set the analytic spatial coordinates dependence of the boundary conditions is added;
- The possibility of producing graphs of the spatial coordinates and time dependency of the boundary conditions is added;
- The generation of console commands for setting up and running the calculation of the graphical interface widgets is added. ;
- Import/export of materials from the graphical interface are added;
- The package includes a new version of Fidesys Viewer with a number of improvements.

Version 1.5

Released: June, 2014

- Static analysis for elastoplastic material models;
- Orthotropic materials;
- Physically nonlinear hyperelastic materials: Mooney-Rivlin and Murnaghan;
- Calculations by spectral element method for hybrid meshes;
- The possibility of parallel calculations on one or more computers using the MPI technology (linear statics, modal analysis, buckling) is added;
- The calculation of the margin of safety in accordance with various strength theories;
- 8-node shell elements SHELL8;
- Console commands to set analysis parameters and to run the calculation;
- The ability to set the time dependence individually for each boundary condition in dynamic problems;
- Windows XP compatibility issues are fixed.



Version 1.4

Released: December, 2013

- Buckling problems;
- Thermal conductivity and thermoelastic problems;
- Curvilinear finite elements;
- Geometrically nonlinear problems;
- The spectral element method for linear and nonlinear two-and three-dimensional static problems and modal analysis;
- Support for hybrid meshes;
- Bug fixing.

Version 1.3

Released: July, 2013

- Beam elements;
- Shell elements;
- Geometry creation of high-speed processes by the spectral element method is added;
- Static and dynamic nonlinear problems;
- High-order finite elements;
- Bug fixing.

Version 1.2

Released: February, 2013

- Computational performance is improved;
- Plane-stress and plane-strain problems;
- The translation into cylindrical and spherical systems is added in the postprocessor;
- The calculation of tensors invariants is added in the postprocessor;
- The visualization of the calculation results as contour lines is added in the postprocessor.

Version 1.1

Released: November, 2012

- Parameter setting and calculation launch from the Main Menu of the preprocessor are added;
- Dynamic transient problems;
- Modal analysis;
- Hexahedral meshes support;
- The operation with projects and the calculation control system are added;
- The postprocessor's localization support;
- The postprocessor performance is improved.

Using the Program

Performing calculations with the use of *CAE Fidesys* implies the following steps:

- Setting the geometry;
- Meshing;
- Setting boundary conditions;
- Setting the material;
- Starting calculation;
- Visualizing and analyzing results.

All of the steps except for the last one are made in preprocessor; the last step is made in postprocessor.

Geometry

CAE Fidesys allows one to generate volume geometry on your own due to the built-in functionality, as well as to import 3D models created in different CAD-systems.

Geometry import

For geometry import choose **File** → **Import** in the Main menu. *CAE Fidesys* supports the import of the following formats:

- ACIS (*.sat, *.sab);
- IGES (*.igs, *.iges);
- STEP (*.stp, *.step);
- Warefront Object (*.obj);
- Stanford Polygon (*.ply);
- Assimp;
- GAMBIT Real Geometry (*.dbs);
- Catia (*.CATPart, *.CATProduct, *.ncgm);
- Parasolid (*.x_t, *.x_b);
- SolidWorks (*.sldprt, *.sldasm);
- ProE (*.ptr, *.asm);
- Abaqus (*.inp);
- STL Files (*.stl);
- Fluent (*.msh);
- GAMBIT Neutral (*.neu);
- Ideas (*.unv);
- Nastran (*.bdf);
- Patran (*.pat, *.neu, *.out);
- Cubit files (*.cub);
- Trelis (*.trelis);
- CATIA v4 (*.model);
- Fidesys Case (*.fc).

Geometry creating

For geometry generation **CAE Fidesys** provides the user with large numbers of volume geometric primitives (parallelepiped, cylinder, prism, cone, pyramid, sphere, torus). It also allows uniting the surfaces in closed volume bodies. For complex geometry generation you can use Boolean operations (Intersect, Subtract, Unite volumes) and different transformations of the object (Rotate, Move, Scale, Reflect). All of the described functionality is available on Command Panel in **Geometry** section.

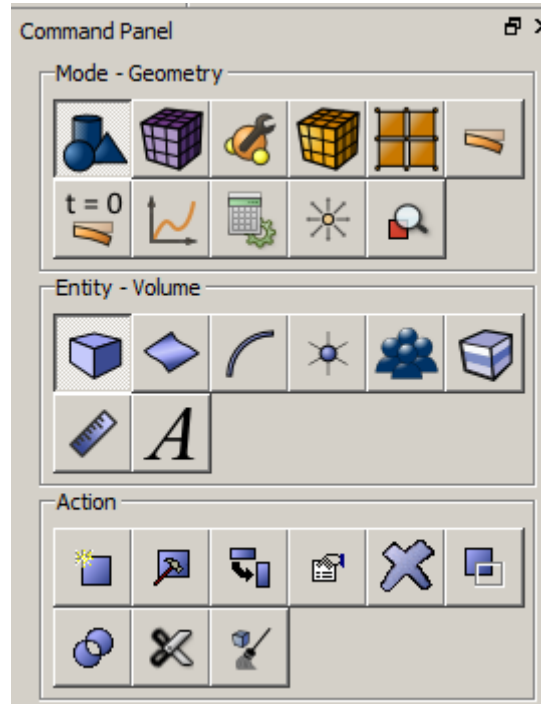

Meshing

CAE Fidesys supports the following types of the finite elements for meshes:

- volume: SOLID (tetrahedrons, hexahedra, pyramids, prisms);
- plane: PLANE (triangles, quadrangles);
- shell: SHELL (triangles, quadrangles);
- beam: BEAM;
- springs: SPRING;
- point masses: LUMPMASS.

The order of all elements, except for springs and point masses, can vary from 1st to 9th. The order of the element above the second means using the method of spectral elements

Volume meshing

Select volume mesh generation section on Command Panel (Mode — **Mesh**, Entity — **Volume**).

- Specify the degree of mesh refinement (Action — **Intervals**) for each volume:
 - Select the volumes (specify their ID). You can enumerate several volumes using space after each of them. All of the volumes can be set by the command **all**;
 - Select the way of mesh generation (Auto, Approximate size, Geometry-adaptive, Interval or Sizing function);
 - Click **Apply Size**.
 -
- Specify the type of the elements for each volume:
 - Select the entities for mesh generation (specify their ID). You can enumerate several volumes using space after each of them. All of the volumes can be set by the command **all**;
 - Select meshing scheme (tetrahedral (Tetmesh) or hexahedral elements (Automatically calculate));
 - For tetrahedral mesh generation select the level of optimization (Extreme, Strong, Heavy, Standard, Medium, Light, or None) and set the checkboxes in front of the corresponding points, if you need to minimize the over-constrained and/or sliver tets.
 - Click **Apply Size**;
 - Click **Mesh**.

For complex geometry it is recommended to set the scheme of surface mesh generation first (triangular or quadrangular elements).

Surface mesh generation

To generate a surface mesh, follow these steps.

- Select surface mesh generation section on Command Panel (Mode — **Mesh**, Entity — **Surface**).
- Specify the degree of reducing of mesh (**Action - Intervals – Approximate size**) of each surface:
 - select volumes (specify their ID). Multiple volumes can be listed through a space; all volumes can be specified using the command **all**;
 - indicate the **Approximate size**;
 - Click **Apply Size**.

To generate an irregular mesh (e.g. make it finer in the vicinity of stress concentrators), you can add nodes on the boundaries near

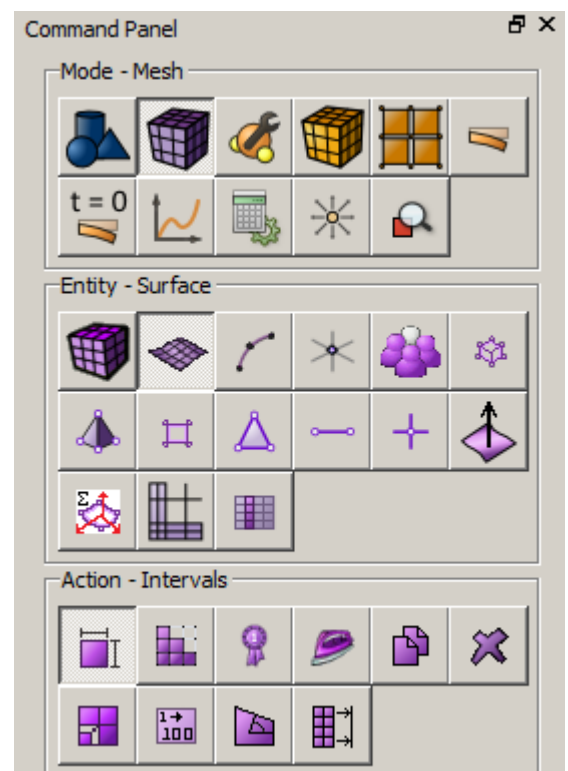
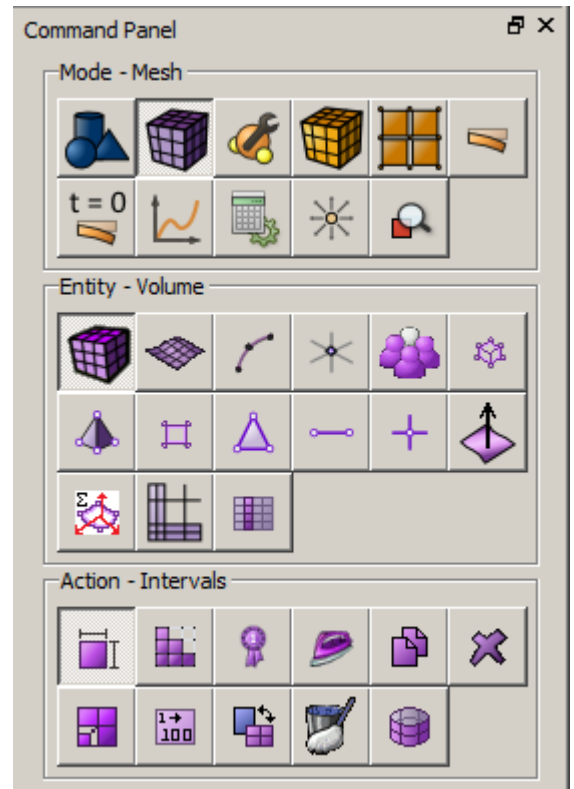



geometry features, as well as split curves, surfaces and volumes in the vicinity of the features.

Using the functionality available on Command Panel you can:

- Check the mesh quality (including checking the mesh quality of individual elements: volumes, surfaces, curves);
- Modify the generated mesh (Refine, Smooth, Delete);
- Renumber the elements and delete the generated mesh.

Setting material and element type

Element types

Set the Material

CAE Fidesys supports the following materials:

- Hooke material;
- Orthotropic material;
- Transversely isotropic material;
- Mooney Rivlin material;
- Material Blatza-Ko;
- Murnaghan material;
- Elastoplastic material (Mises criterion, Drucker-Prager);
- Thermoelastic material;
- Poroelastic material (Bio Model).

For Mooney-Rivlin and Murnaghan materials, the following defining relations are used.

Mooney-Rivlin potential:

$$W = C_1(\bar{I}_1 - 3) + C_2(\bar{I}_2 - 3) - D(J - 1)^2,$$

where D , C_1 , C_2 are Mooney-Rivlin material constants.

Relation of D , C_1 , C_2 and Poisson's ratio ν :

$$D = \frac{C_1 + C_2}{1 - 2\nu}.$$

Murnaghan potential:

$$\Sigma_{0,n} = \lambda(\varepsilon \cdot I)I + 2G \varepsilon + 3C_3(\varepsilon \cdot I)^2 I + C_4(\varepsilon \cdot \varepsilon \cdot I)I + 2C_4(\varepsilon \cdot I) \varepsilon + 3C_5 \varepsilon^2$$

where λ , G , C_3 , C_4 , C_5 are Murnaghan material constants.

To set the new material, select the setting material properties section on Command Panel (Mode –**Materials**, Entity – **Materials Management**).

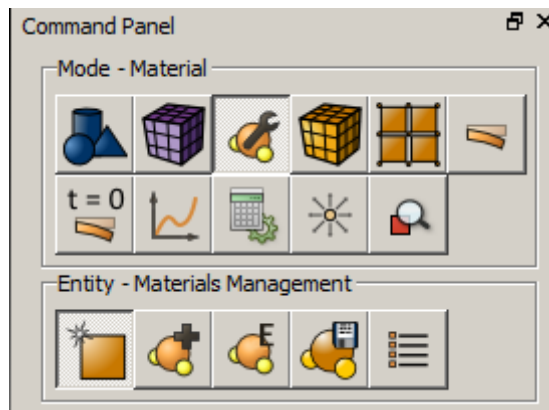

Material properties are set in the Materials Management widget.

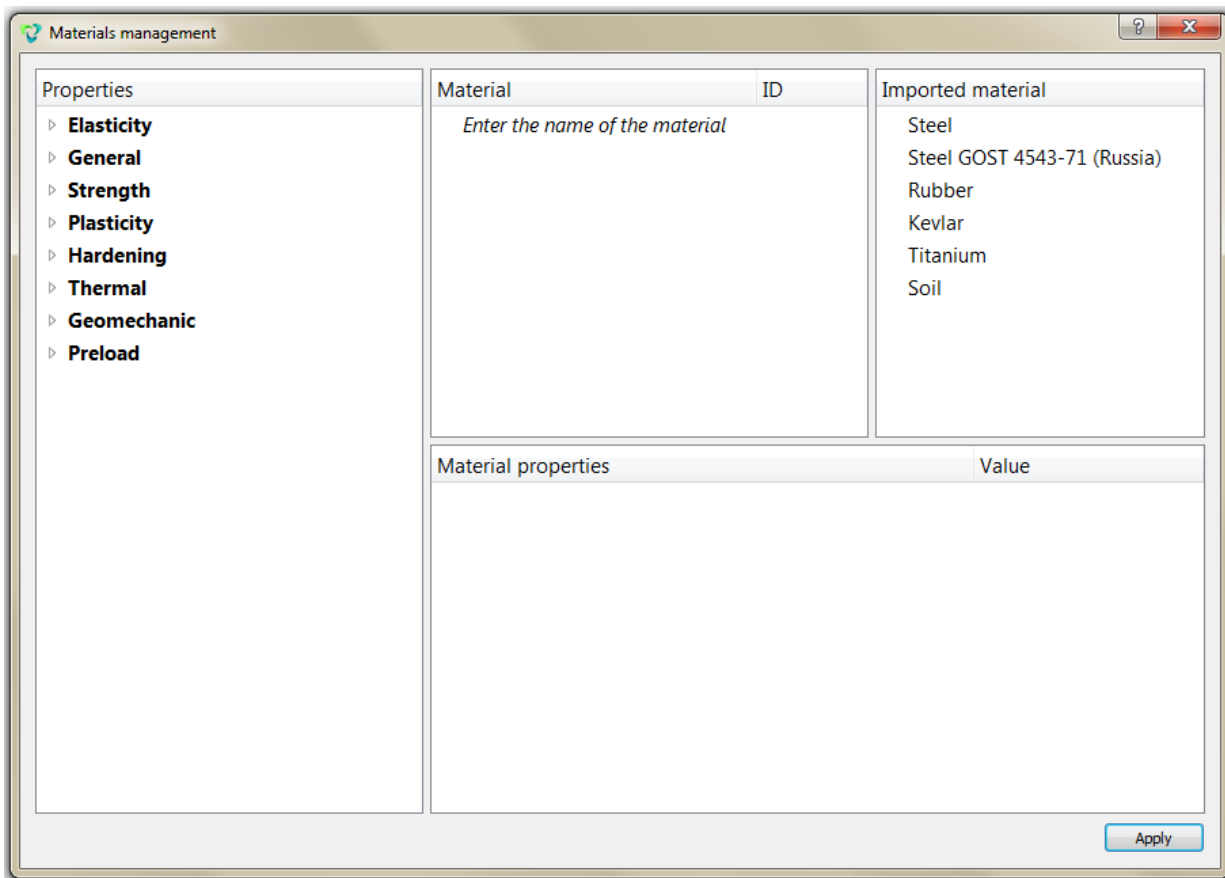

Next, using the “drag & drop” method, add the necessary characteristics from the left column to the Material Properties column.

Select the desired characteristic with the mouse. Hold down the left mouse button and drag the label to Material Properties. Double-click in the Value field opposite the property that appears and specify the correct value.

The right column shows the preset materials. To use these materials in the calculation also drag the material of interest into the Materials column (where the active materials are located). Click the Apply button.

Upon successful addition, the created materials should appear in the Model Tree in the Materials section.

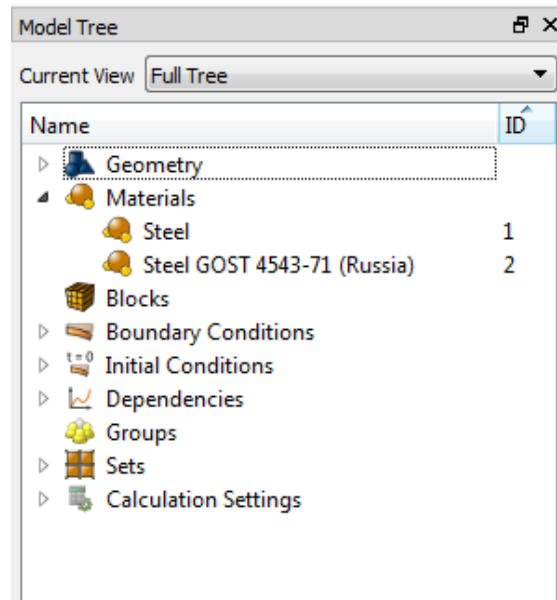

Note: In order to link the material and the model, **Block** is used.

Setting tabular dependencies for materials

To create tabular dependencies for material characteristics, double-click in the Value field opposite the desired property. A button with a triple point will appear. Click this button. The **Edit Table** widget opens, where you can set table dependencies.

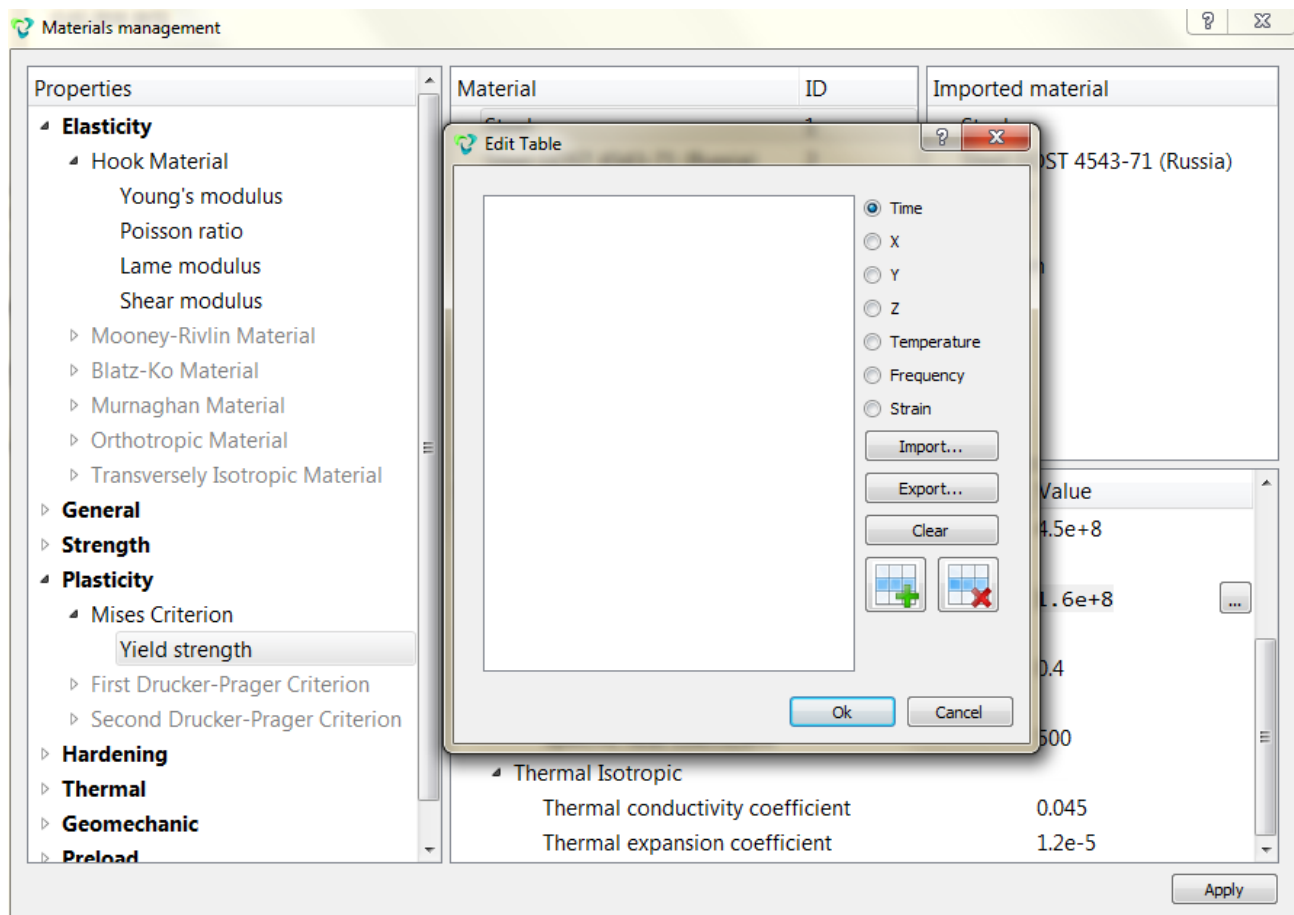

To specify a formula dependence, simply enter the appropriate formula in the Value field and then click **Apply**.

Material properties	Value
▼ Hook Material	
Young's modulus	200*t
Poisson ratio	0.3521
▼ Second Drucker-Prager Criterion	
Cohesion	1.505e+7
Internal friction angle	31.1066
Dilatancy angle	31.1066
▼ Thermal Isotropic	
Thermal conductivity coefficient	8e-6

Import/Export Material

To import materials, right-click in the Imported Material column. A context menu appears in which you must select Import. Specify the path to the imported material.

Panel settings for an existing material are changed, if an added material with the same name already exists in previously imported materials:

- If it is allowed to overwrite it, then put the Overwrite checkbox.
- If you need to add near an existing one, then put the Append checkbox, and the material will be added with renaming.
- By default, the check is set to Ignore - the material is not imported, the previous material remains.

Click **Apply**. Next, drag the imported material into the active materials column (Material). Click **Apply**.

CAE Fidesys supports importing material in XML format.

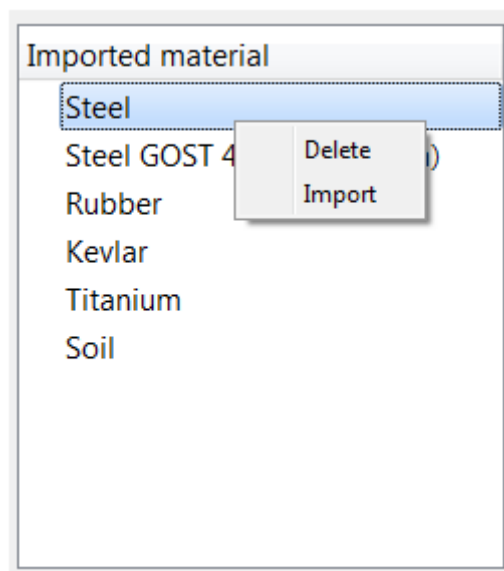

To export the created material, right-click on the material name, select Export in the context menu. Specify the path to save to the file, click **Apply**.

Material	ID
Steel	1
Steel GOST 4543-71 (Russia)	2
<i>Enter the name of the material</i>	

Delete
Export

If the value of a property is not entered, then by default it is assumed to be zero (except for the shear modulus, which is determined automatically based on the entered values of E and ν).

Setting the yielding model

The choice of the correct model of the material plastic flux is very important to obtain a proper solution of the problem. Plasticity problems are nonlinear, therefore, they require substantial computer resources and solving problems with large plastic strains may take a long time. The Fidesys system of strength analysis for the Hook material realizes two criteria of transition into plasticity: the Mises criterion and the Drucker-Prager criterion. Problems are solved both for perfectly elastoplastic models and for models with linear hardening. It is currently implemented the approach taking into account finite strains in the elastic zone; the linear formulation of the problem is used in the zone of plastic flux.

Von Mises yield criterion

In order to add the Mises plasticity to the Hook material, please select the section for setting material properties on the Command Panel (Mode - **Blocks**, Entity - **Materials Management**).

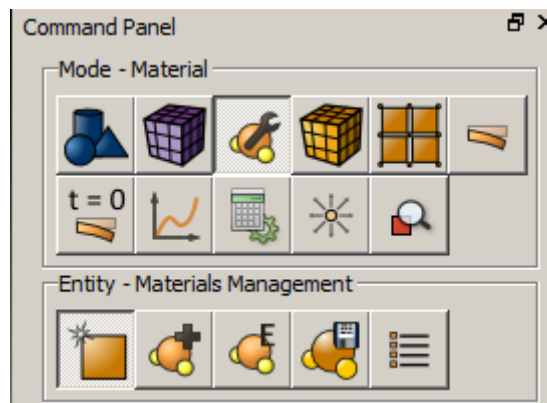

Specify the name of the material. From the left column, drag the Hooke Material inscription into the Material Properties column. Fill in the Values fields accordingly:

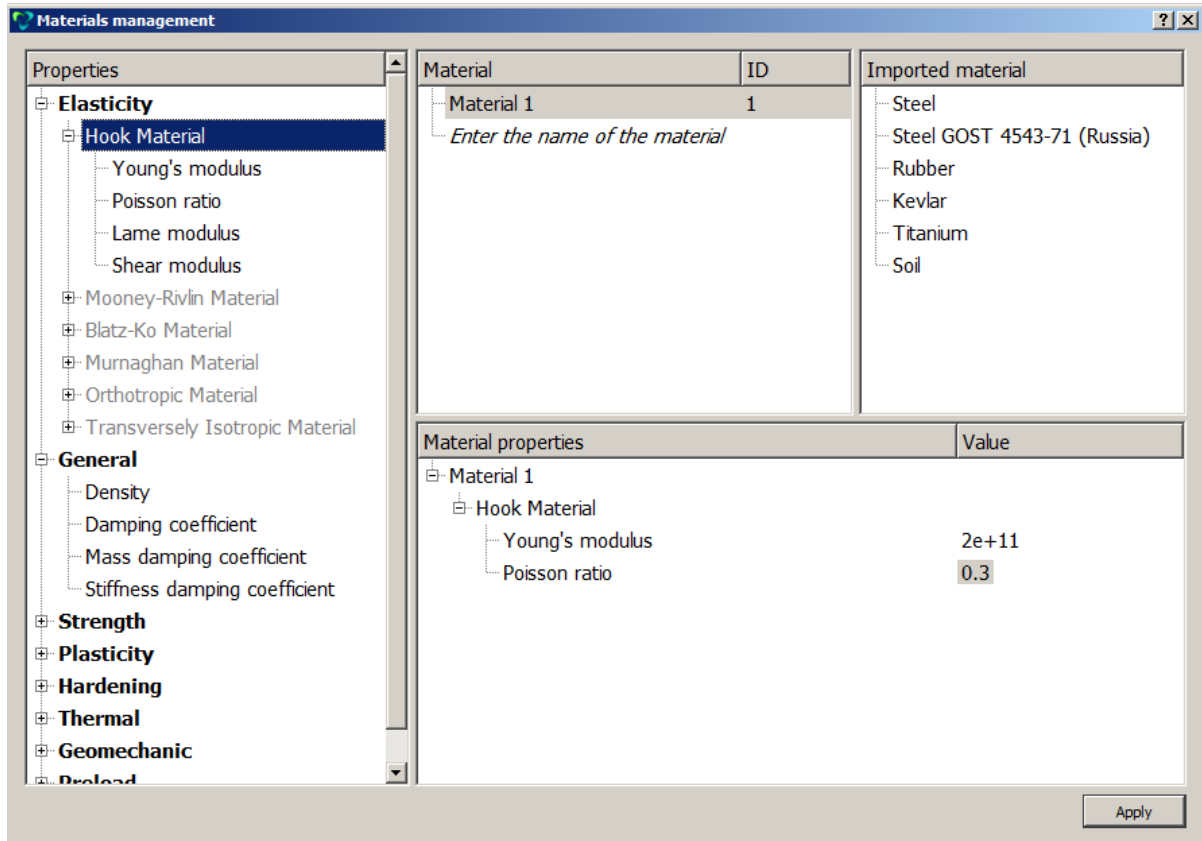

To create the model with the von Mises plasticity without hardening, set elastic properties of the Hook material as well as the **yield strength**:

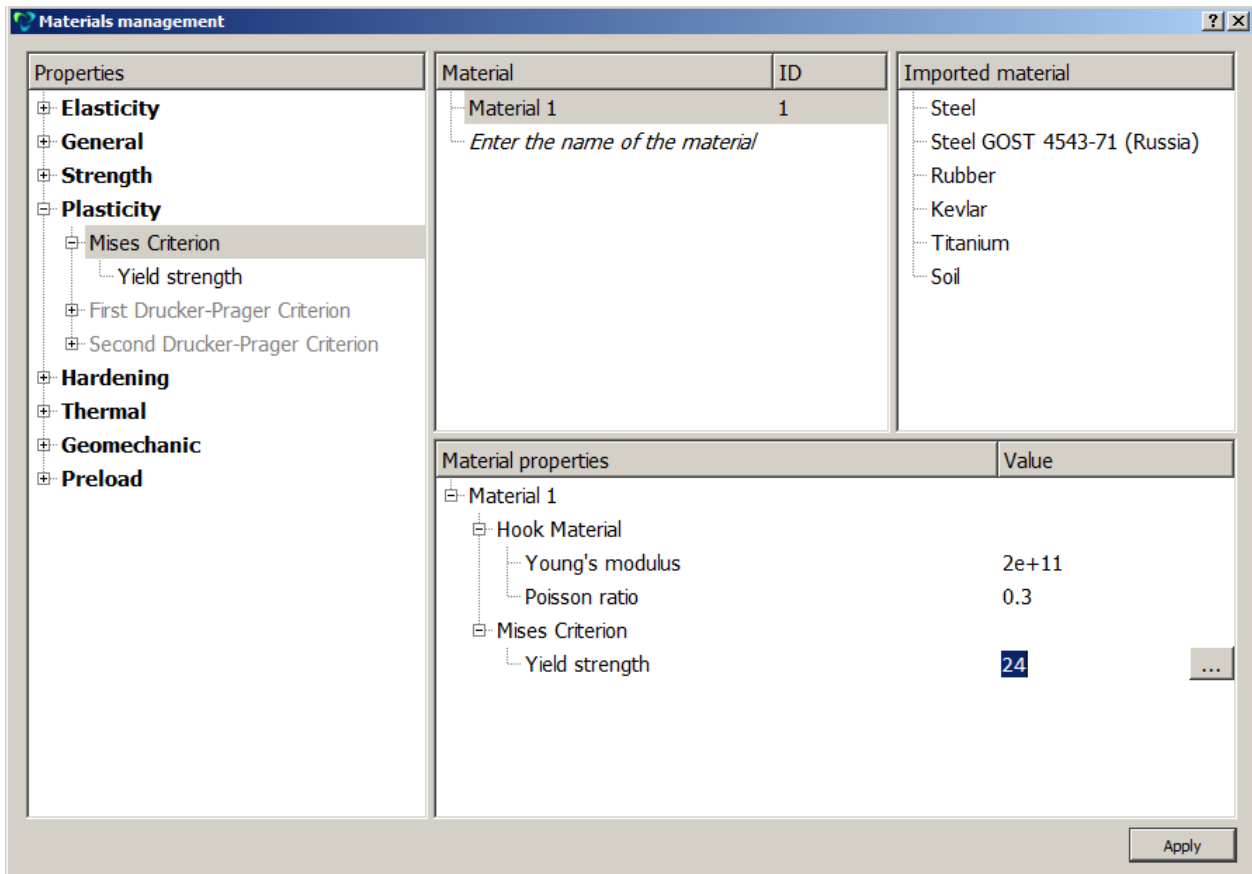

To create the Mises plasticity model with linear hardening, it is also necessary to enter the yield strength in tension and the ultimate strain in tension.

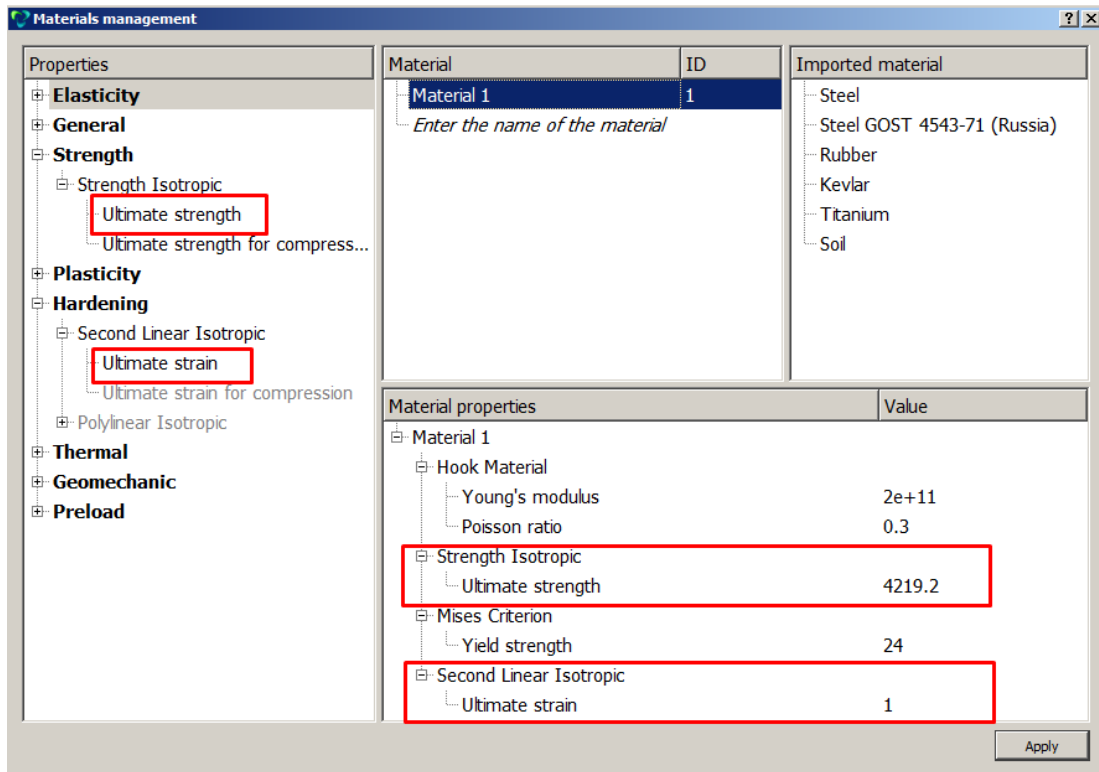

Drucker-Prager yield criterion

There are two ways to specify the Drucker-Prager plastic model without hardening in the **CAE Fidesys** software package - "**First Drucker-Prager Criterion**", "**Second Drucker-Prager Criterion**", which become available in the "Materials Management" widget after specifying elastic constants.

"**First Drucker-Prager Strength Criterion**" implies the setting of the material properties "**Yield strength**", "**Yield strength for compression**":

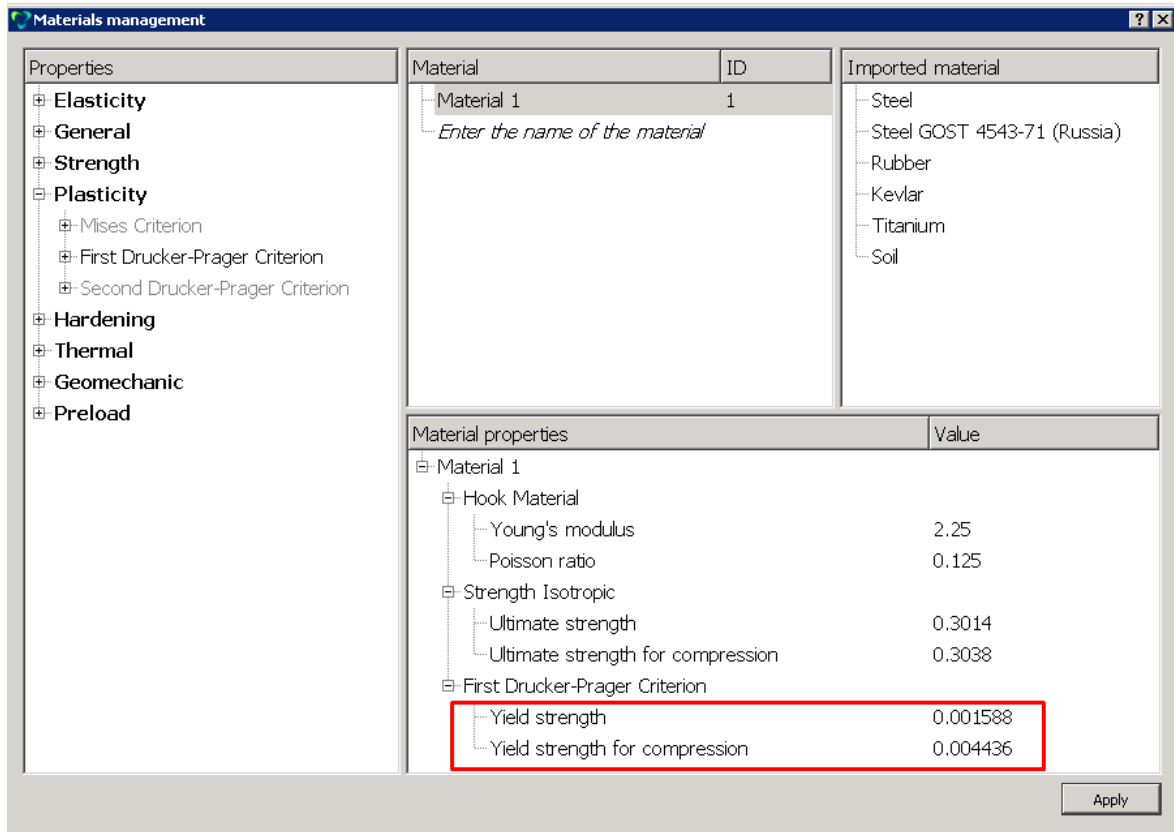

To use the "Drucker-Prager Second Criterion " it is necessary to enter the properties of the material "Cohesion", "Internal friction angle", "Dilatancy angle ":

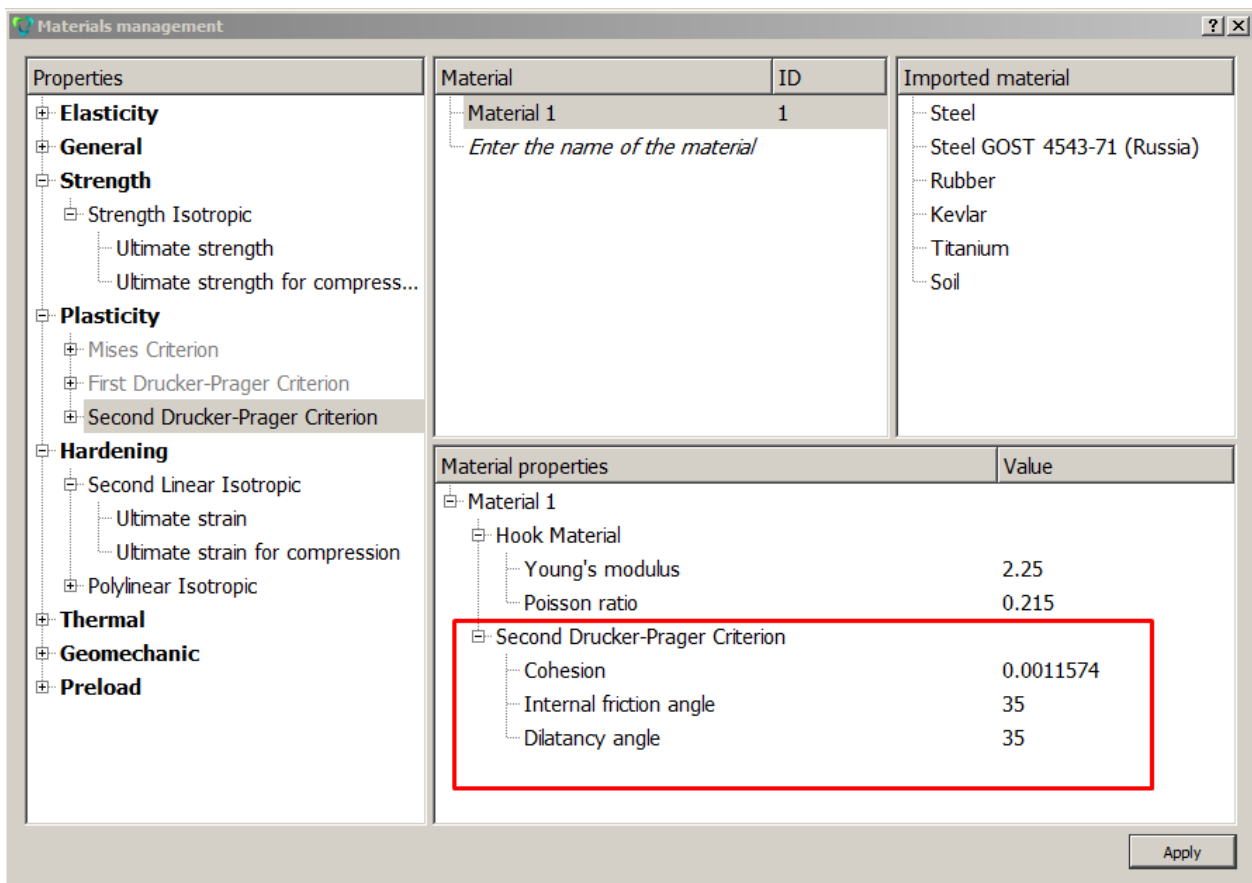

To obtain a Drucker-Prager plasticity model with hardening, also specify the limits of strength and ultimate strain for tensile and compression (available for both the first and the second plasticity criterion according to Drucker-Prager):

The screenshot shows the 'Materials management' dialog box. The left sidebar contains a tree view of material properties. The 'Strength' and 'Hardening' sections are highlighted with red boxes. The 'Material properties' table on the right shows the following data:

Material properties	Value
Material 1	
Hook Material	
Young's modulus	2.25
Poisson ratio	0.125
Strength Isotropic	
Ultimate strength	0.3014
Ultimate strength for compression	0.3038
First Drucker-Prager Criterion	
Yield strength	0.001588
Yield strength for compression	0.004436
Second Linear Isotropic	
Ultimate strain	1
Ultimate strain for compression	1

Polylinear hardening

Also, with the Mises plasticity in **CAE Fidesys**, a more general type of hardening is available - polylinear hardening, for which you need to fill in the table property of the material "**Sigma(epsilon) curve**" material (in the table pairs of values from the strain on plastic component "plastic component of deformations ϵ_{11} " - "true stress S_{11} "):

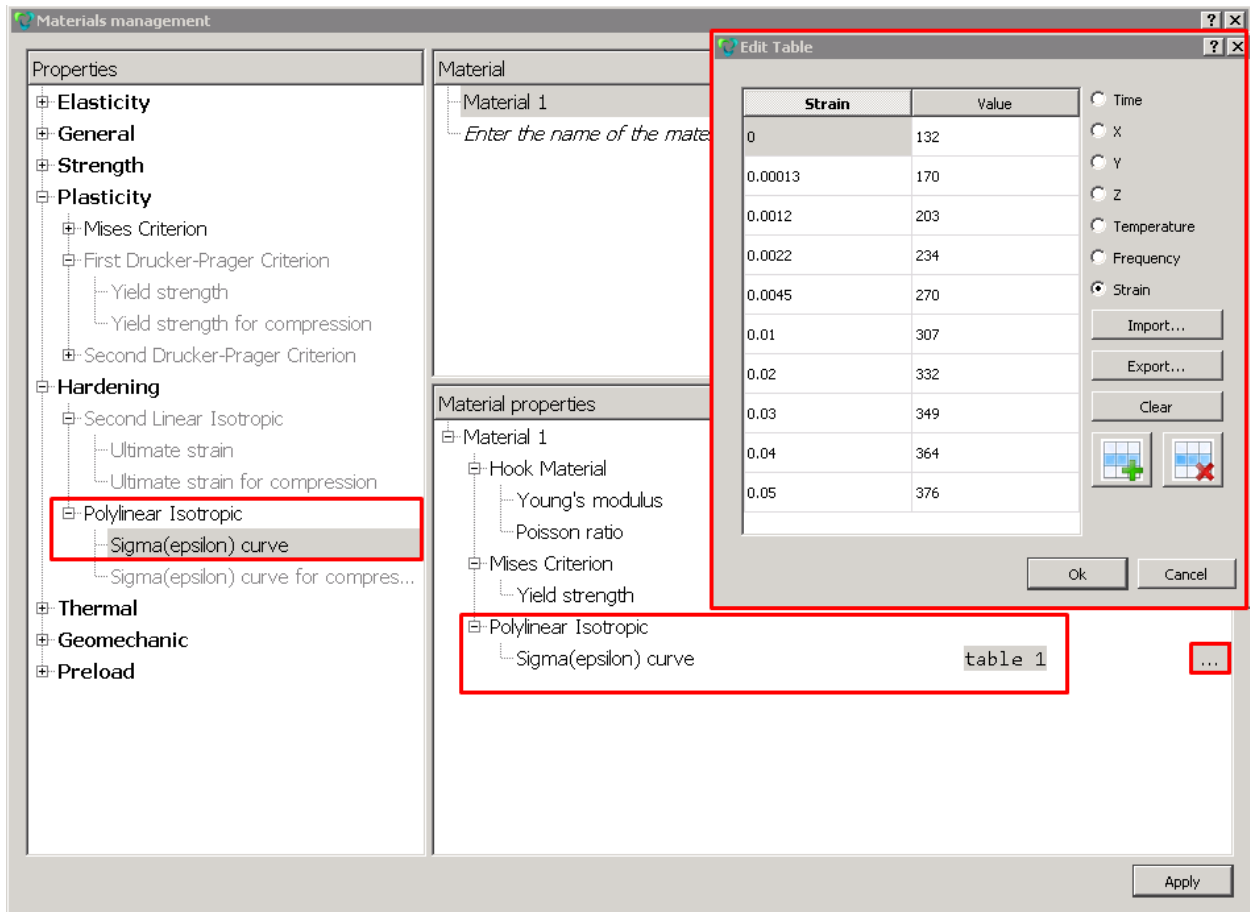

Element types

CAE Fidesys supports the solution of elastoplastic problems for the following types of already existing finite elements:

- Solid elements (3D);
- Shell elements (2D).

Blocks operations

A block must contain an element type, ID and the name of the geometric model of the material. It is recommended to create several blocks if several materials or several types of geometric entities are used in the calculation.

For example, if a structure contains solid and shell elements, it is necessary to create a block for each type of element. If the construction consists of beams with different types of sections, then for each type of section you need to create your own block.

The sequence of operations with blocks can be schematically represented as follows:

- To create block specifying geometric Entity ID;
- To assign the material to the block;
- To assign the element type to the block.

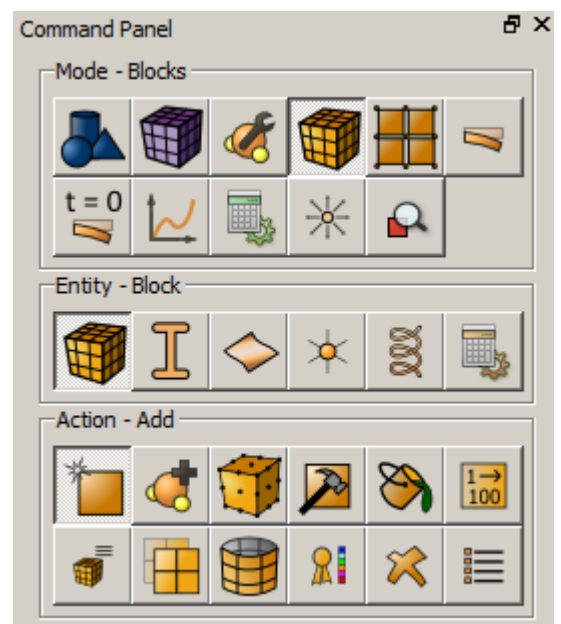

Let us consider these steps in detail.

- To create a new block, please, go to Mode – **Blocks**, Entity – **Block**, Action – **Add**.
In the Entity list drop-down menu, select the type of geometric objects that will be included in the block.

Click **Apply**.

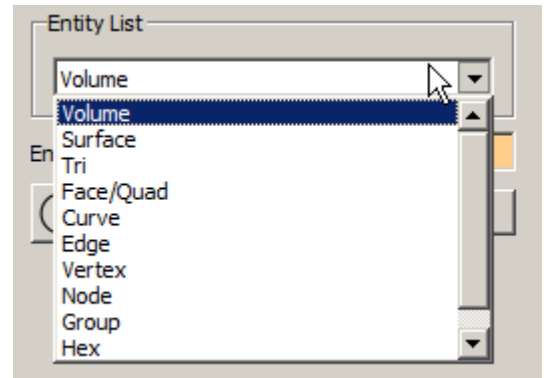

You can find out the ID of the geometrical entities united into the block as follows:

- in the Model Tree on the left;
- by clicking on geometrical objects you are interested in – their ID will automatically appear in the appropriate field.

The block ID field must specify a sequence number.

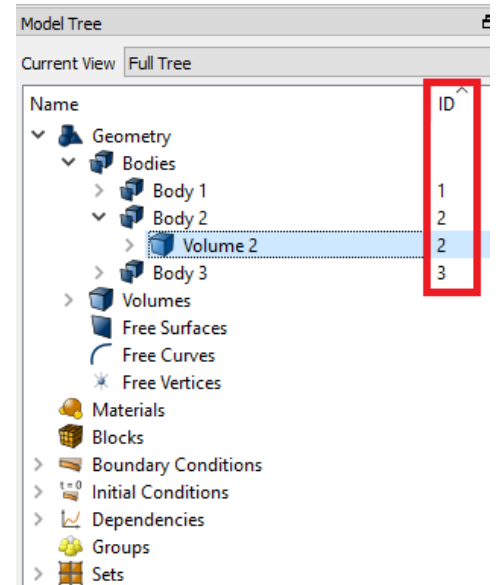

Note: Created block must be displayed in the Model Tree on the left in the section **Blocks**.

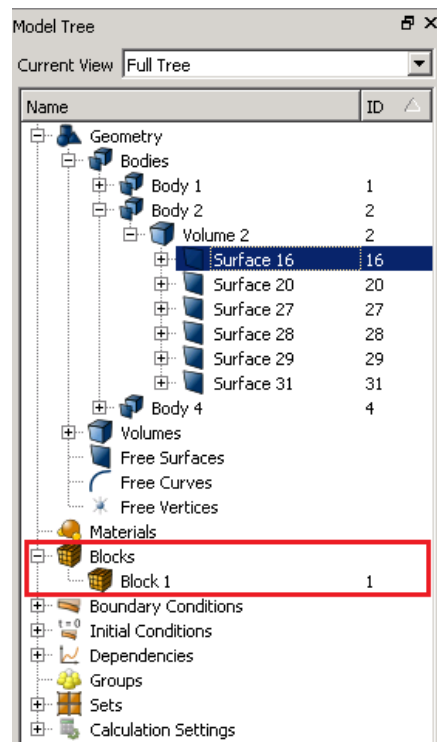

To look through the list of the geometrical entities united into the block, enter in Command Line List block 1.

In the Console, you will see the list of entities united into the block.

- To assign the material to the block, select **Block – Set material** in the drop-down list.

To enter the block ID, you can do it manually or click on the corresponding geometric entity. Available material is selected from the drop-down list.

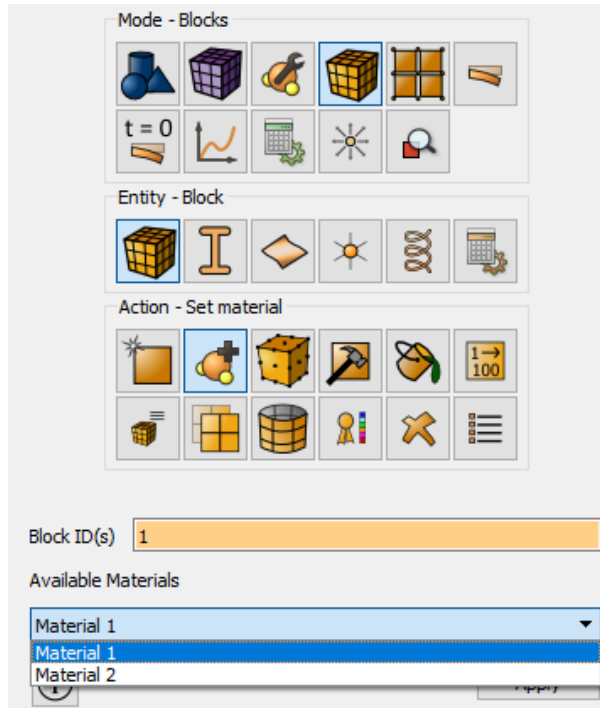

Click **Apply**.

- To set the element type, select **Element Types** in the drop-down list.

The block ID can be entered manually, or by clicking the mouse on the corresponding geometric object.

In the Category field, select the item that corresponds to the entity added to the block.

Specify the order of the element. The order can be selected from 1 to 9.

Click **Apply**.

Note: Order 2 corresponds to the choice of the element of the second order, where intermediate nodes are added on the edges. The order of the element 3 and further means that the calculation will be carried out by the method of spectral elements of the corresponding order.

The following categories are available for the according element types:

- Point mass: LUMPMASS.
- Spring: SPRING.
- Beam: BEAM.
- Shell: SHELL.

- Plane (2D): PLANE.
- Solid: SOLID.

If an element type is not assigned to a block, the program selects it by default based on the type of the geometric object contained in the block. The following rules are used:

- Volumes meshed by SOLID elements.
- Surfaces meshed by SHELL or PLANE elements.
- Curves meshed by BEAM or SPRING elements.
- Vertices correspond to single-node elements LUMPMASS.

Nodes corresponding to the higher order of approximation are arranged in accordance with the default curved geometry. To change this rule, you can use the command:

set node constraint [ON | off | smart]

Setting **off** corresponds to the location of nodes of a higher order without taking into account the curved geometry; they occupy middle positions between the corner nodes of the elements: in the middle of straight edges, in the centers of flat surfaces, etc. The **smart** setting only takes the curvature into account when it does not degrade the quality of the elements.

Setting shell properties

CAE Fidesys supports shell elements SHELL.

To set the properties of the shells - thickness and eccentricity - go to Mode - **Blocks**, Entity - **Shells Properties**. On the panel that appears, specify:

On the appeared panel, specify:

- Block ID;
- Thickness;
- Eccentricity.

Note: Eccentricity by default must be equal to 0.5.

The eccentricity for the shell element varies from 0 to 1 and determines the distance between the surface of the shell, considered in the geometric or finite-element model, and the middle surface of the shell (in fact, the thickness offset of the middle surface relative to the upper surface of the shell in proportion). By default, eccentricity is set to 0.5.

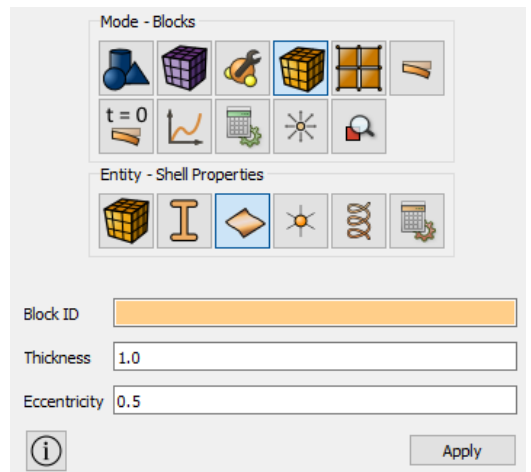

3D shell cross section view is possible in the **Fidesys Viewer** postprocessor by clicking 3D-view button in the default string.

Setting beam properties

CAE Fidesys supports beam elements BEAM.

To specify beam cross section using geometric features and moments of inertia, go to Mode – **Blocks**, Entity – **Beam parameters**.

On the appeared Panel, specify:

- Block ID;
- CS Rotation Angle;
- cross section profile and the appropriate dimensions to it.

Click **Apply**.

CAE Fidesys supports beam cross section of the following types:

- Rectangle;
- Ellipse;
- I-Beam;
- Channel;
- Corner;
- T-Beam;
- Z-Beam;
- Hollow Rectangle;
- Trough profile;
- Circle With Offset Hole;
- definition of section by means of the moments of inertia.



3D beam cross section view is possible in the **Fidesys Viewer** postprocessor by clicking 3D-view button in the default string after the calculation is complete.

Command Panel

Mode - Blocks

Entity - Beam Properties

Block ID

CS Rotation Angle

Offset to

Select profile

- I-Beam
- Rectangle
- Ellipse
- I-Beam
- Chan-Beam
- L-Beam
- T-Beam
- Z-Beam
- Hollow Rectangle
- Hat-Beam
- Circle With Offset Hole
- Custom Section

Height (H)

Bottom Width (B_1)

Top Width (B_2)

Bottom Thickness (c_1)

Top Thickness (c_2)

Thickness (d)

Y Eccentricity

Z Eccentricity

Calculated properties:

Inertia moment I_y

Inertia moment I_z

Inertia moment I_x

Inertia moment on torsion I_t

Area

Apply

Specifying Sphere element properties

CAE Fidesys supports point masses LUMPMASS.

To set the properties of point mass, go to Mode - **Blocks**, Entity – **Sphere element Properties**.

On the panel that appears, specify:

- block ID;
- mass;
- Inertia moment.

Click **Apply**.

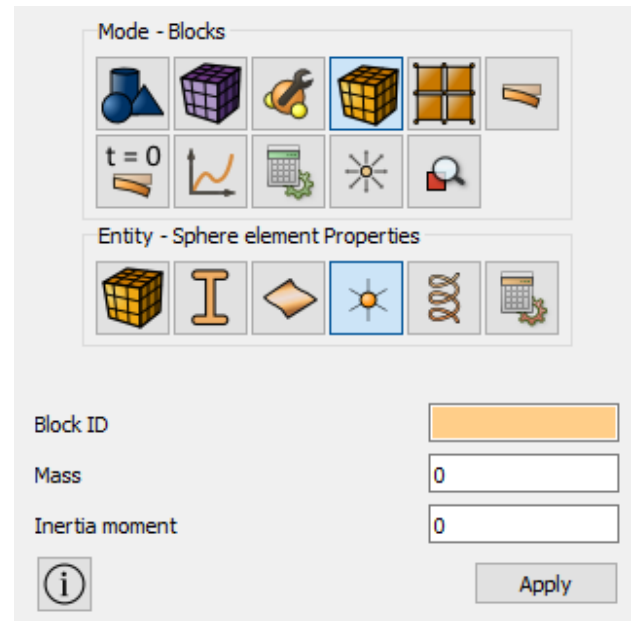

Set spring properties

CAE Fidesys supports springs (spring elements).

To set the properties of the spring, go to Mode - **Blocks**, Entity - **Spring Properties**.

On the panel that appears, specify:

- Block ID;
- Spring type;
- Values corresponding to the type of spring.

Click **Apply**.

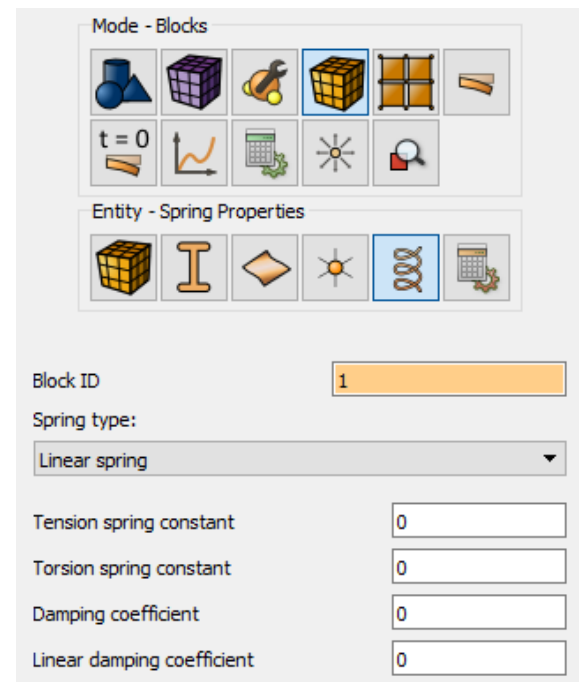

Setting boundary conditions

Types of boundary conditions

CAE Fidesys supports boundary conditions of the following types:

- Force;
- Pressure;
- Displacement;
- Distributed force;
- gravity;
- Stress;
- Acceleration;
- Speed;
- Angular velocity;
- Coupling constraint;
- Contact;
- Absorbing BC;
- Heatflux;
- Pore pressure.

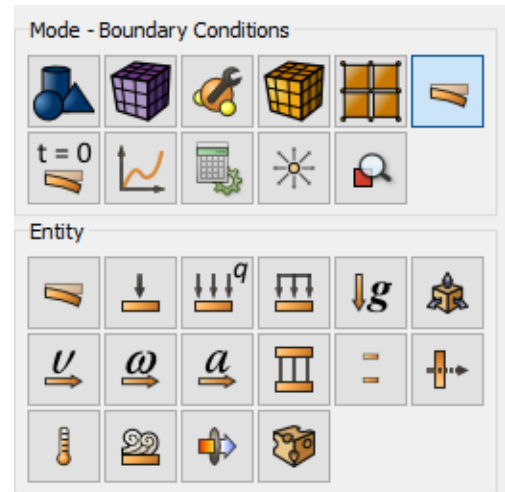

To set boundary conditions, follow these steps:

1. Select Mode— **Boundary conditions** on Command Panel.
2. Select Boundary Condition Type in **Entity** block.
3. Select Action — **Create**. Set the following parameters:
 - ID/Name (assign a new ID, enter a name using letters and/or numbers, or use the system assigned ID);
 - Entity where the boundary condition is applied (Volume, Surface, Curve, Edge, Vertex, Node, Nodeset, Element, Side, Sideset);
 - Entity ID(s) (point mouse cursor at the field Entity ID(s) and select the necessary entities with a mouse, their numbers will be entered into the field automatically. If you need to specify several entities, mark them holding down the Ctrl key);
 - Other parameters (Value, DOFs, etc.).
4. Click **Apply**.

Using the functionality available on Command Panel you can also see the list of Boundary Conditions, modify or delete the boundary condition you previously set.

Setting initial conditions

Types of initial conditions

CAE Fidesys supports the following initial conditions

- displacement
- speed
- angular velocity
- temperature
- pore pressure
- initial stress (set in Materials Management)

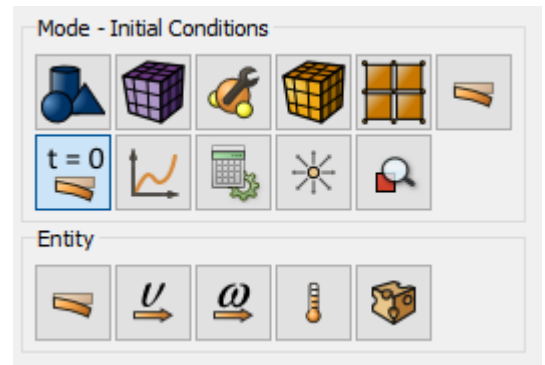

Time/coordinate dependency

The time/coordinate dependency can be specified separately for each type of boundary conditions using tabular and formulaic dependencies.

The boundary conditions must be set in advance (Mode – Boundary Conditions)..

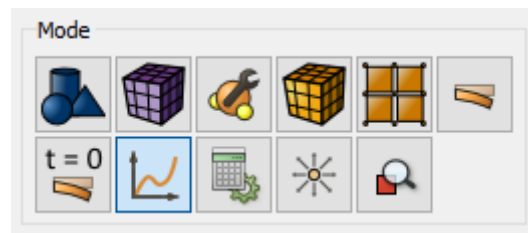

To set the formulaic dependency on Command Panel, select **Mode – BC Dependency**, and in the appeared form:

- Select BC Type;
- Select an individual component or an entire vector for time dependency application;
- Select Dependency Type (formula can be entered manually, you can use the standard formulae for the time dependency);
- Set Dependency Parameters.

Click **Apply**.

To view a tabular data or graphs plotted by a given formula, go to the corresponding tabs in the window BC Dependency. In addition, there is a possibility to export tabular data or to import new tables.

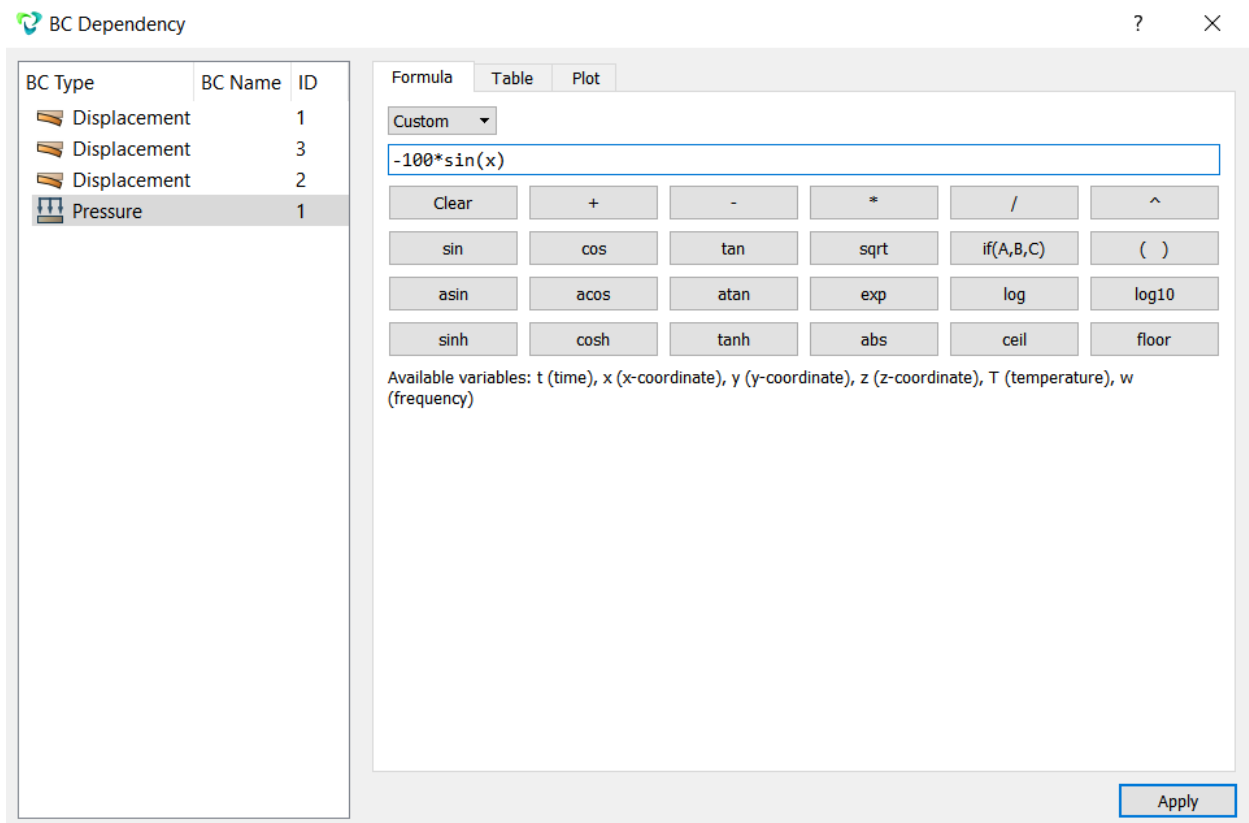

Here are standard formulae for the time dependency:

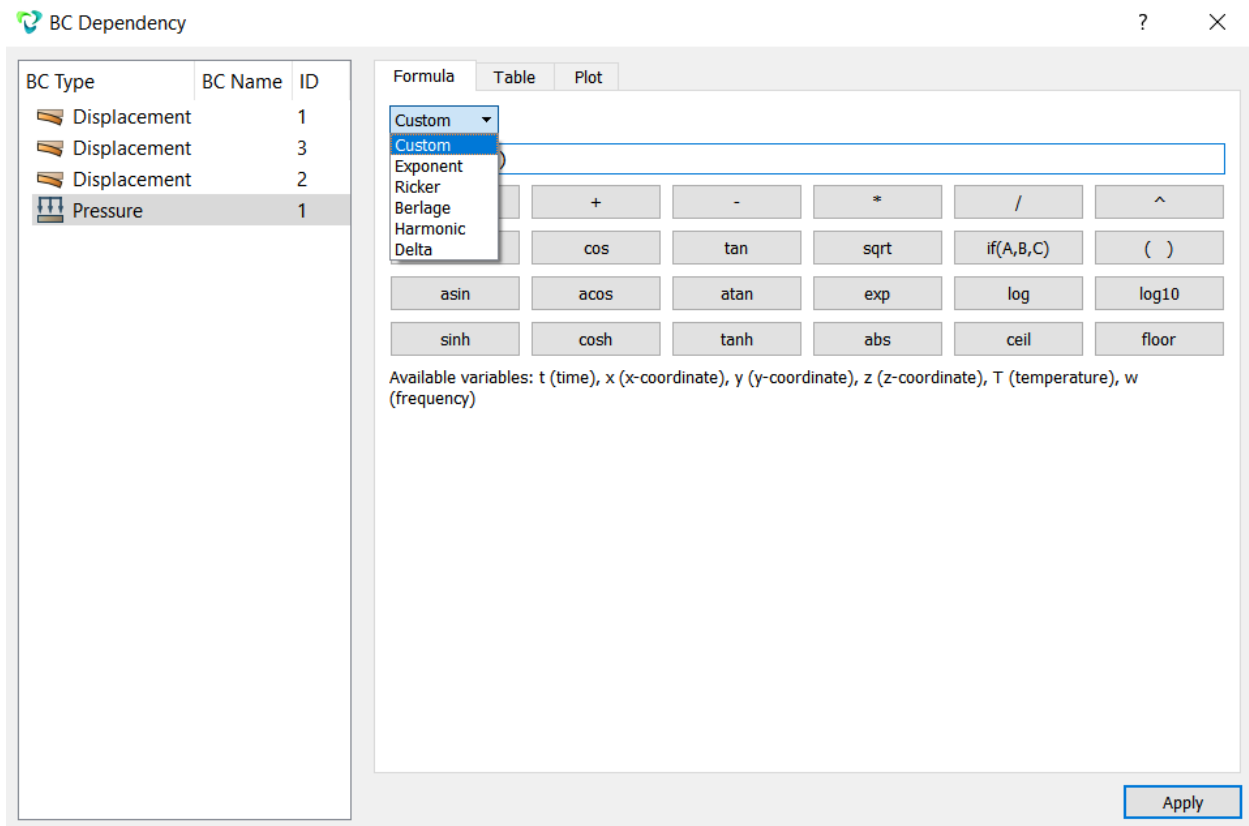

Viewing of the tabular data corresponding to the formula $-100*\sin(x)$:



BC Dependency

BC Type	BC Name	ID
Displacement		1
Displacement		3
Displacement		2
Pressure		1

Formula Table Plot

X	Value
-10	-54.4021
-9.8	-36.6479
-9.6	-17.4327
-9.4	2.47754
-9.2	22.289
-9	41.2118
-8.8	58.4917
-8.6	73.4397
-8.4	85.4599
-8.2	94.0731
-8	98.9358
-7.8	99.8543
-7.6	96.792

Time
 X
 Y
 Z
 Temperature
 Frequency

Import...
Export...
Clear

Apply

Viewing of the graph corresponding to the formula $-100*\sin(x)$

BC Dependency

BC Type	BC Name	ID
Displacement		1
Displacement		3
Displacement		2
Pressure		1

Formula Table Plot

Set Range

Apply

Setting contact interaction

Contact problems are highly nonlinear and require significant computer resources to be solved. Thus, to select the model resulting in the most effective solution, it is very important to understand the physical content of the problem. Two factors determine nonlinear nature of contact problems. Firstly, it is the contact area and consequently, the boundary conditions are unknown until the solutions. Secondly, it is necessary to take into account the friction in many contact problems. Effects related to the friction can result in poorly converging problems.

Contact region

To set contact areas, select the Contact dialogue (Mode - **Boundary conditions**, Entity - **Contact**)

CAE Fidesys implemented node-surface and node-curve contact interactions.

Note: if the contact conditions are not specified, then the parts in the assembly do not interact. The interaction of assembly parts through the specified contact area means an obstacle to the mutual penetration of parts and the transfer of loads.

It's recommended to assign contact zones to separate surfaces in 3D and lines in 2D. The contact regions should be large enough so that the process of interaction of bodies does not outstepping, but at the same time it is recommended to minimize these regions to save computer resources.

Specify which of the entities will be the Master, and which - the Slave.

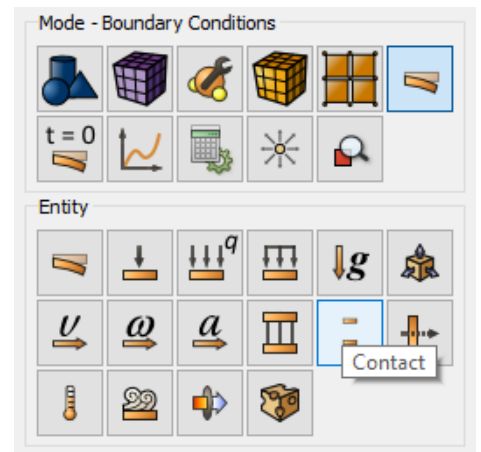

Action - Create

Master and Slave selection ▼

ID

New ID

System Assigned ID

Master Entity:

Entity List

Surface ▼

Entity ID(s)

Slave Entity:

Entity List

Surface ▼

Entity ID(s)

Offset

Ignore Initial Overlap

Type General ▼

Friction Value

Method Auto ▼

Set detection settings

Apply

It should be noted that the Master is simulated by surfaces, and the Slave - by nodes.

When building a contact pair, it should be kept in mind that the choice of Master and Slave can cause various results and influence on the accuracy of the solution.

Recommendations for the selection of Master and Slave entities:

- If one surface (A) is flat or concave, and the other surface (B) is a sharp edge or bulge, then surface A should be the Master.
- If both contacting surfaces are convex, then the Master surface is assumed to be less convex.
- If both surfaces are flat, the choice of Master and Slave entities is arbitrary.
- If one contact surface has a sharp edge, and the other one does not have it, then the first is taken as a Slave surface.
- If one of the contacting bodies is rigid, then its surface is assumed to be the Master.
- In some cases it is useful to create a symmetrical contact. In addition, each surface is defined as the Master, and as a Slave. It's possible to simulate, for example, the contact of two areas with sharp edges or grooved (undulating) surfaces by this methods.

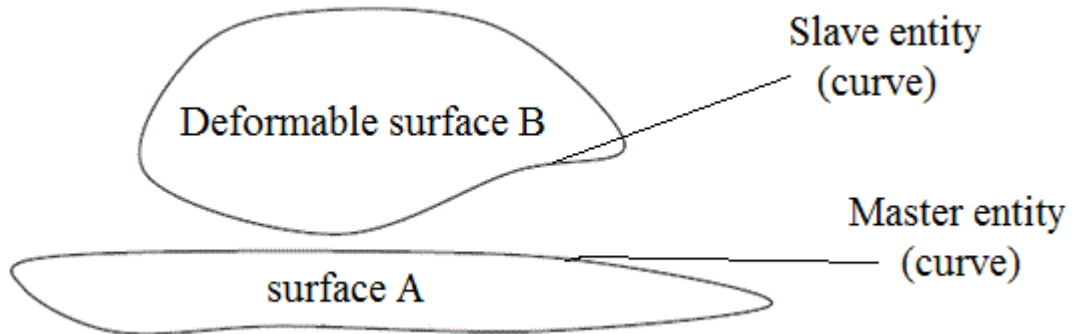

Autoselection of contact

CAE Fidesys implements the automatic definition of contacting entities. To do this, select Autoselect in the drop-down list and select the corresponding entity in the Geometry panel.

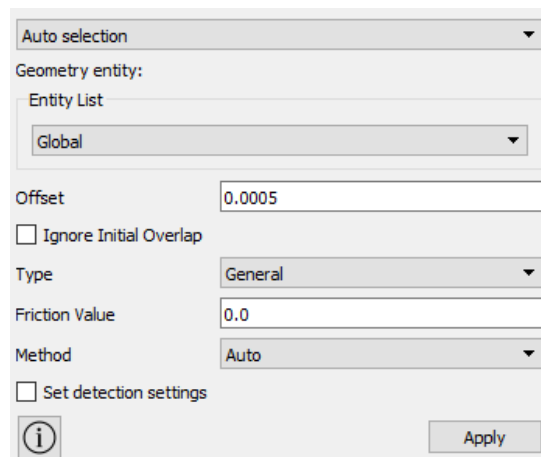

The applied contact pairs are displayed on the left side of the screen in the objects tree. Click on the name of the desired contact region in the Model Tree to visualize, and it will be highlighted on the model.

Offset - is the distance between bodies at which contact interaction started. It can be considered as the size of a rigid body between the contacting bodies.

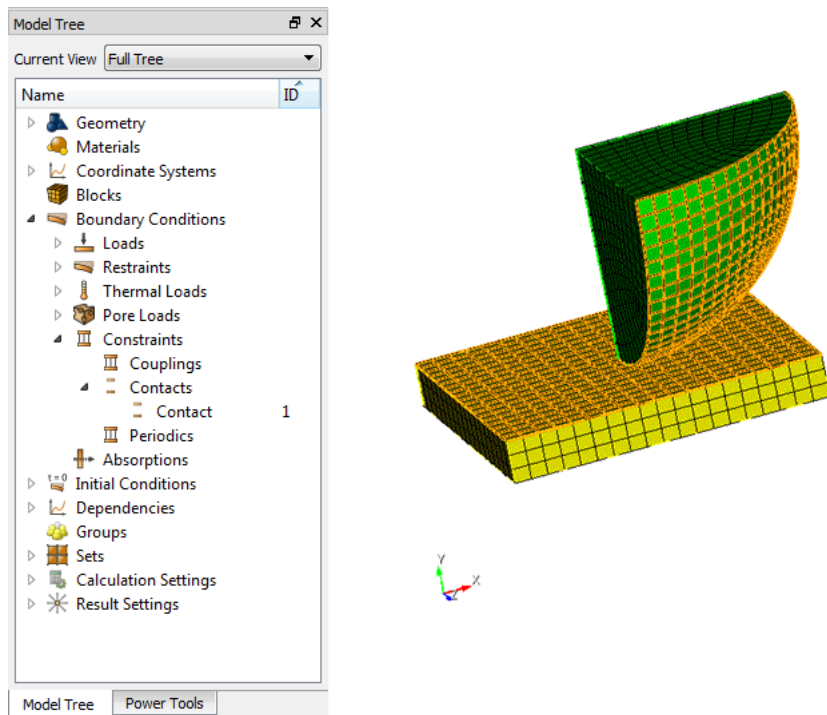

Each contact pair is assigned with an individual number (ID) and a set of properties. The number of contact pairs is not limited. To visualize the created contact pair, click with the mouse on the name of the required contact pair on the left in the same tree of objects. The selected pair will be highlighted in yellow on the model.

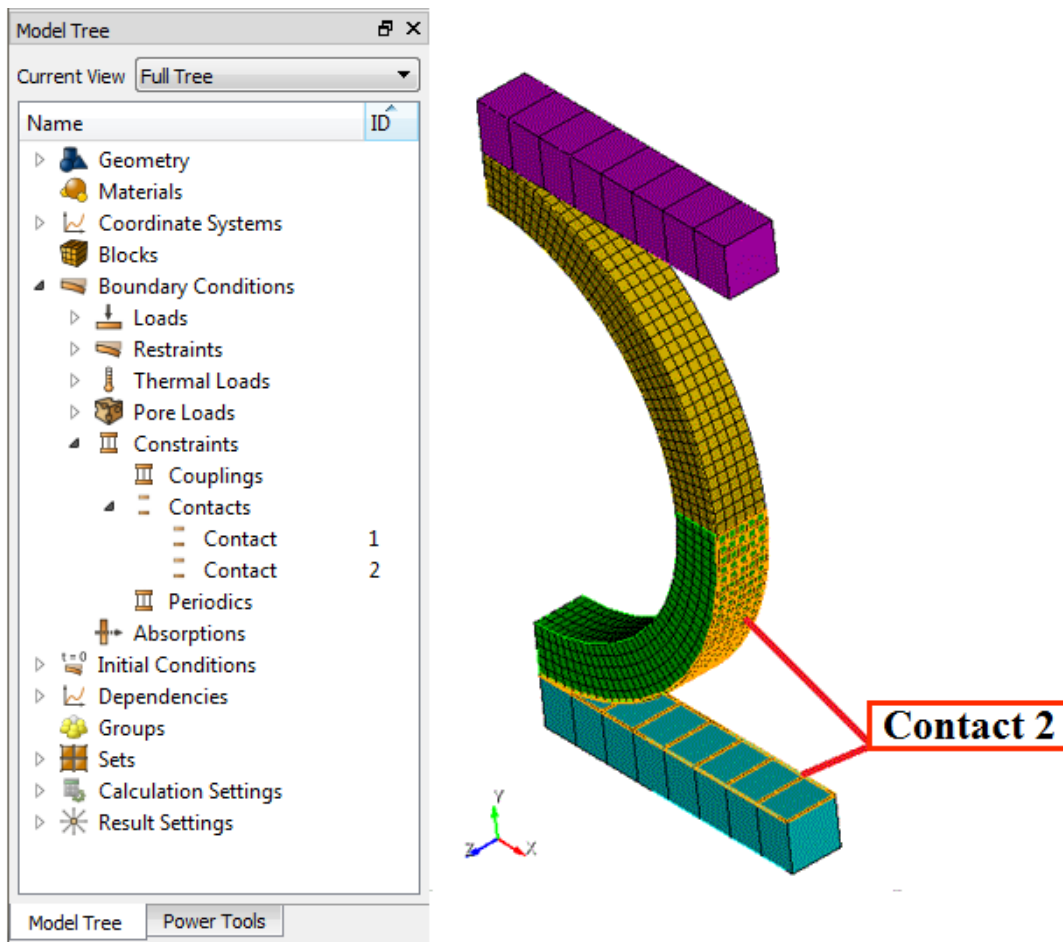

The following contact pair settings are available in *CAE Fidesys*:

Offset	0.0005
<input type="checkbox"/> Ignore Initial Overlap	
Type	General
Friction Value	0.0
Method	Auto

To simulate a bonded contact, select the type of contact **Tied**. Then, if the contact is created, Master and Slave entities merge in all directions so that displacements and stresses are continuous through the contact zone.

If the motion of a rigid body is limited only by contact conditions, it is important to ensure that the elements of the contact pair are in interaction in the initial state. However, in some cases, the definition of interaction can be difficult. This can occur in the following cases:

- body contours can be complicated, and it is difficult to define the point at which the first contact will occur;
- in spite of the fact that the geometric model is constructed without gaps, floating point errors arising while meshing the model can lead to the appearance of small gaps/overlaps between the elements.

For the same reasons, an initial penetration of the Master entity into the Slave one can occur. In these cases, excessively large reactive forces may appear in the contact elements, and this may lead to a **divergence of the solution**.

Therefore, the definition of initial contact is perhaps the most important aspect of building a model for contact analysis.

Contact algorithm

CAE Fidesys implements the following contact algorithms:

- Penalty,
- Augmented Lagrangian,
- Multipoint Constraint (MPC).

When selecting the Auto method, the program automatically selects one of the listed algorithms to solve the contact problem.

Methods of Penalties and Augmented Lagrangian require adjustments for both normal and tangential stiffness (see Contact pair settings). The main disadvantage is that the penetration between the two surfaces depends on these stiffnesses. Higher stiffness values can reduce penetration, but can lead to poor conditioning of the global stiffness matrix and poor convergence. Ideally, it is necessary to choose high enough stiffness so that the contact penetration remains small enough. At the same time, sufficiently low stiffnesses provide the best convergence of the problem.

The MPC method imposes the requirements of non-penetration and equality of normal stresses, for the application of which the method of Direct elimination is used. This approach does not require the defining of stiffness and provide a solution by one iteration (if the contact zone does not change).

Elements Type

CAE Fidesys computational algorithms make it possible to simulate a contact with non-conformable mesh. It **does not require** the use of any special finite elements in the contact area to denote the interaction of parts. This approach allows to easily set the conditions for interaction in contact or for connected surfaces.

The solution of elastoplastic problems in CAE Fidesys is supported for the following types of existing finite elements:

- Solid elements (3D);
- Plane elements (2D).

Contact status

The behavior of each contact element can be visualized in *Fidesys Viewer* by the **Contact Status** field.

This field has one component, which has one of the following values:

- STATUS = 0 - far;
- STATUS = 2 - contact with slippage;
- STATUS = 3 - without slippage (or without friction).

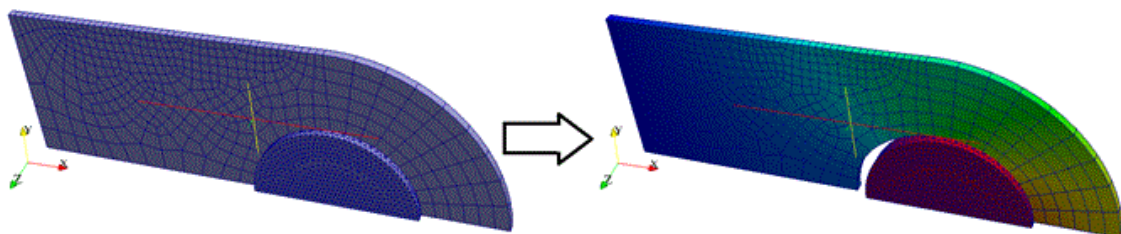

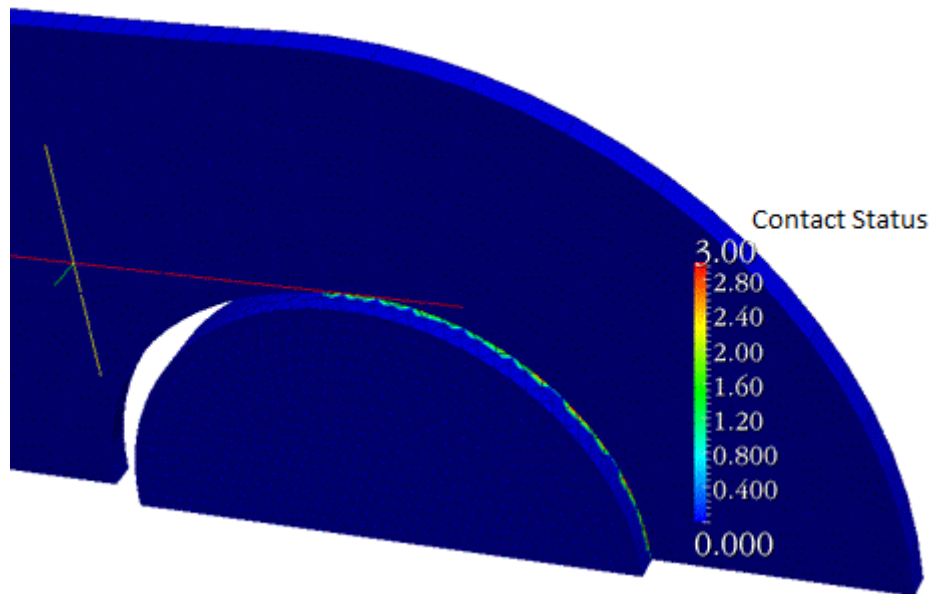

Starting calculation

Analysis types

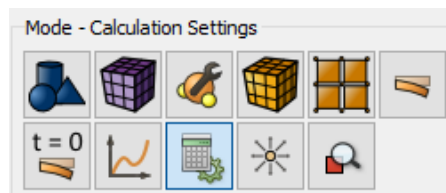

CAE Fidesys includes the following types of analysis:

- Static (1);
- Dynamic (transient) (2);
- Modal (3);
- Harmonic (4)
- Buckling (5);
- Composite materials effective properties calculation (6).



When starting calculation follow these steps:

1. Select Mode – **Calculation settings** on Command Panel.
2. Select the necessary type of analysis: Static, Dynamic, Modal, or Effective properties analysis.
3. Set the parameters of the type of analysis you chose: solver type, coordinate system, fields, scheme, time settings (for dynamic analysis), etc.

4. Click **Apply**.
5. Click **Start Calculation**.

After starting calculation its process will be displayed in the console. It will also output the messages for the user, including the errors in case of unsuccessful or incorrect finishing of the calculation. If the calculation is finished successfully, you will see the following message in the console: "*Calculation finished successfully at <date> <time>*".

All the calculations are made in Cartesian coordinate system by default. If necessary, you can also convert the results into cylindrical and spherical coordinate systems (use the appropriate filters in **Fidesys Viewer**).

The dimension of the calculated problem is 2D or 3D. The following types of 2D problem are included:

- Plane stress;
- Plane strain.

Stress, strain and displacement fields are calculated by default. If necessary, you can also calculate principal stresses, strains, and Mises stress intensity (use the appropriate filters in **Fidesys Viewer**).

The following types of solvers of linear systems (systems of linear algebraic equations (SLAE)) appearing while discretizing the problem, are available:

- Direct (LU)
- Iterative.

The following solvers for problems of modal analysis at systems of linear algebraic equations (SLAE) are available:

- Krylov- Schur;
- Arnoldi.

For dynamic load, one of the two calculation schemes can be used:

- Explicit
- Implicit.

Types of analysis

For the calculation, the following mechanical models are supported:

- Elasticity;
- Plasticity;
- Nonlinear geometry;
- Heat transfer;
- Pore Fluid Transfer.

To choose a model, the user selects the appropriate checkboxes. Selecting multiple checkboxes simultaneously allows setting various combinations of models. For example, the selection of the checkboxes Elasticity and Plasticity gives an elastoplastic model and the selection of the checkboxes Elasticity and Thermal conductivity gives a model of thermoelasticity.

To improve the convergence of nonlinear problems, use the following settings:

Set nonlinear solver options

Nonlinear solver options

Min load substeps: 10

Max load substeps: 30

Max iterations: 100

Tolerance: 1e-3

Target iterations: 5

Line search

Arc-Length method

For nonlinear problems, convergence of iterations at each loading step can be checked in the file *Convergence.txt*. The file is downloaded into the folder that is created next to the file *.pvd which stores the calculation.

For effective performance of several calculations you can use the **Results** on Command Panel (see the section **Result Analysis**).

For visualization and analysis of the obtained results you can use the program *Fidesys Viewer* included into the package.

Multistep solution

Setting steps for boundary conditions

In *CAE Fidesys*, it is possible to specify a multi-step loading through tabular dependence on time or through explicit assignment of steps.

The tabular dependency is set in the section *Set time and/or coordinate BC dependency*, and you should set the time dependency flag. Setting the load like:

Time	Value
1	5
2	0

means a linear decrease of the value from 5 to 0.

Explicit assignment of steps for boundary conditions occurs in the *Load step settings window (Mode - Calculation settings – Static - Set load steps count)*.

Enter the required number of calculation steps. To open the window of load step settings, click the icon .

Next, specify the required settings:

- Select the BC;
- Click in the left column for the boundary condition for which you want to set active steps of calculation.
- Set the active calculation steps for the selected boundary condition in the corresponding field.
- Setting active steps is possible in the following format: "all", "1 2 3 to 5", "1 to 5".

Click **Apply**.

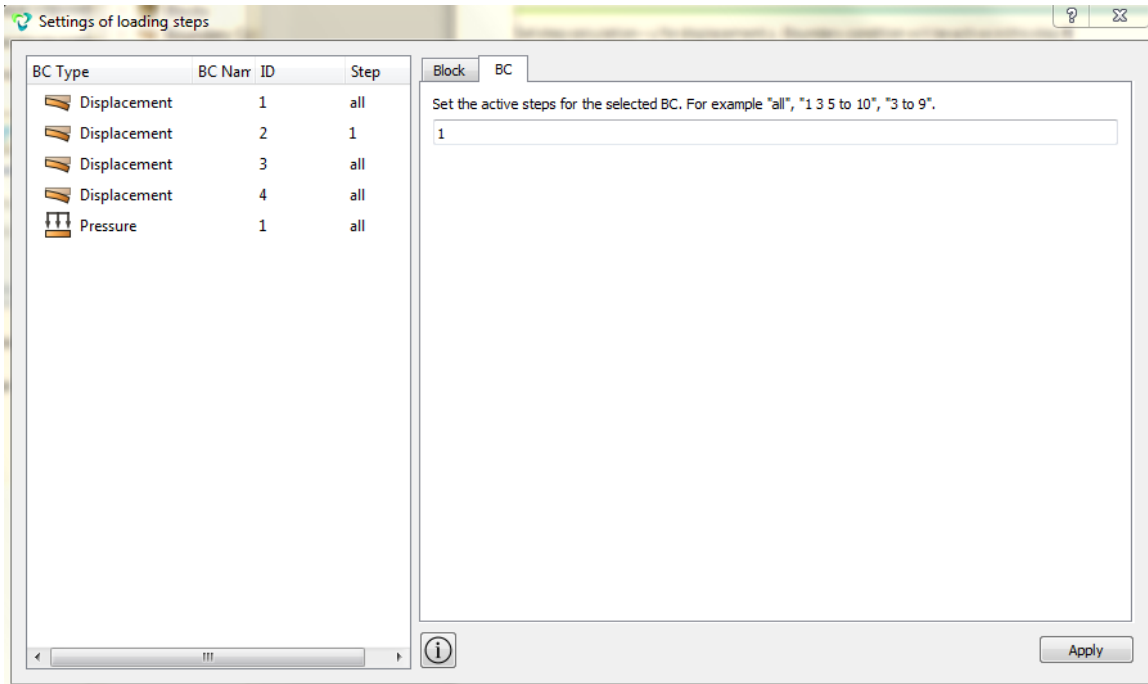

An example of a problem using active calculation steps for boundary conditions (at each step a new movement is added):

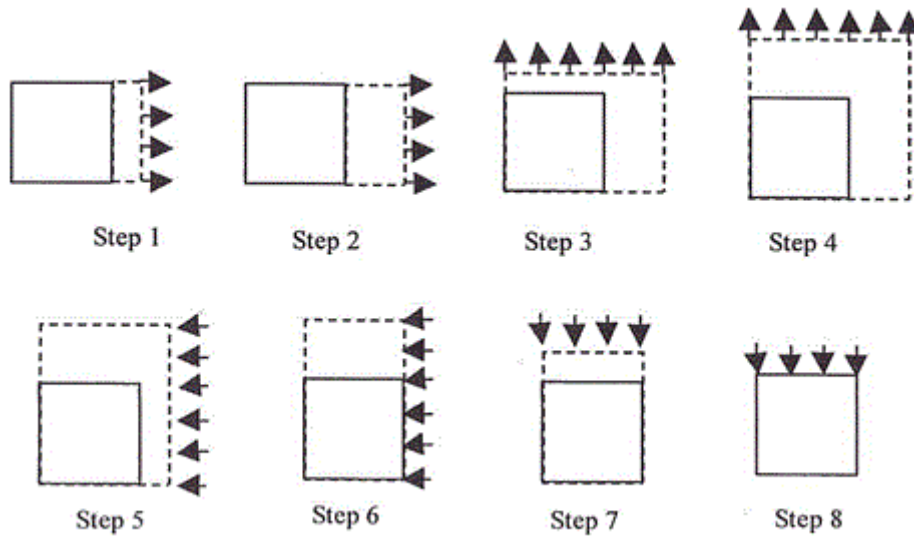

[The solution of the same problem in CAE Fidesys:](#)

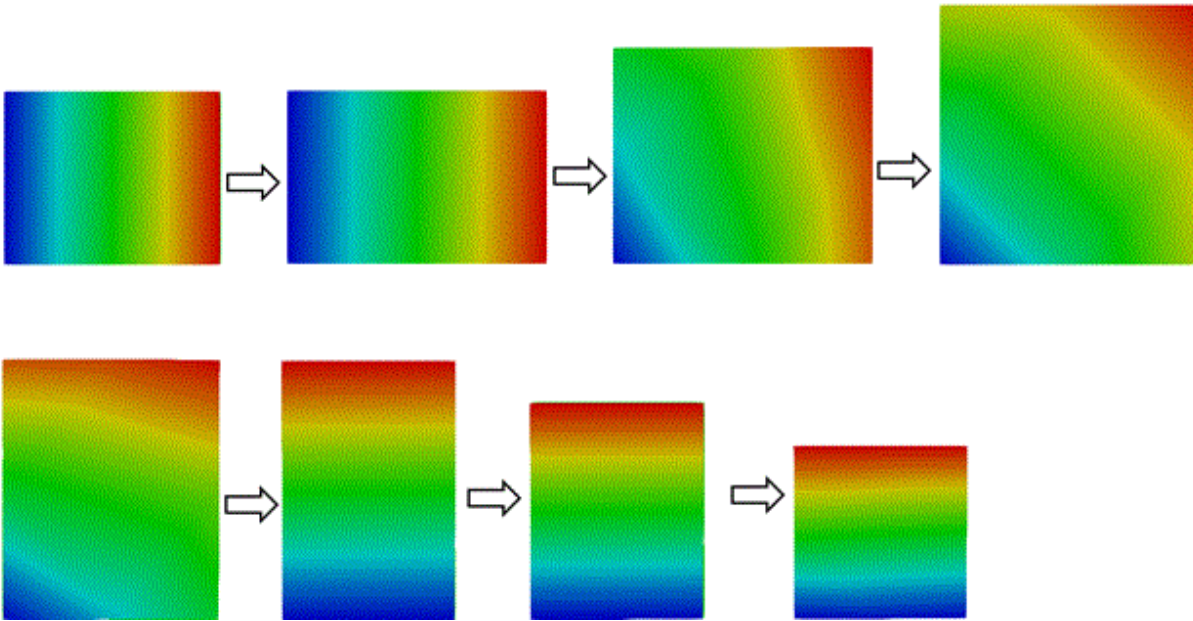

Setting steps for blocks (volumes)

CAE Fidesys allows you to add or remove blocks (volumes \ surfaces added to the block) at specified loading steps.

Adding or excluding blocks in the calculation process takes place in the Setup of load steps window (Mode - Calculation Settings - Static / Transient / Buckling - Set load steps count). In this case, all operations occur on the basis of blocks, therefore for all geometric entities a block(s) must be created in advance.

Go to the Settings loading steps window. On the general solver settings panel, enter the required number of calculation steps and click the icon .

Next, specify the required settings:

- Select the Blocks;
- Click on the block in the left column;
- Set the active calculation steps for the selected block in the corresponding field;
- Setting active steps is possible in the following format: "all", "1 2 3 to 5", "1 to 5".

Click **Apply**.

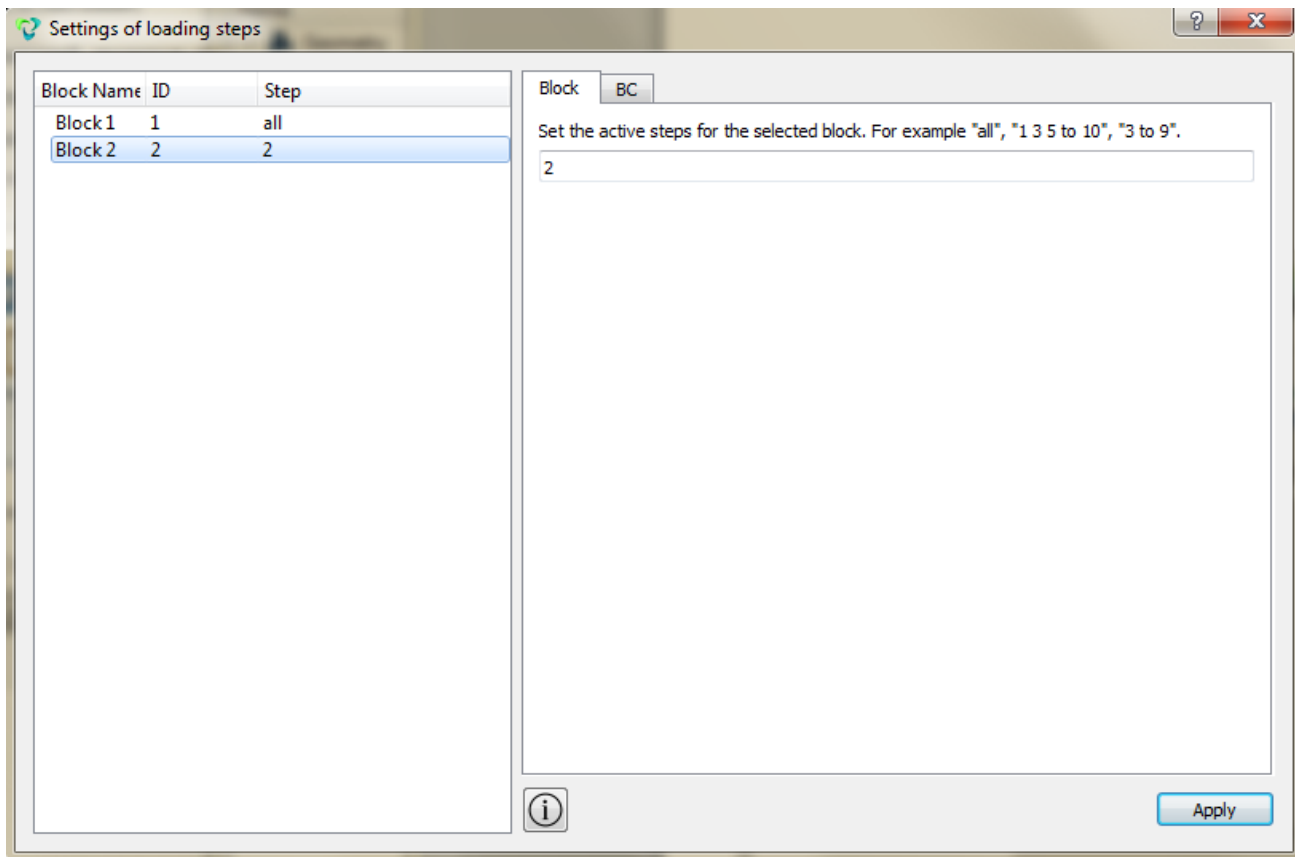

An example of a problem with using active calculation steps for boundary conditions (at the first step, the model is compressed, at the second step one of the fixings is removed, a new volume is added to the deformed model, now two volumes are combined to compress):

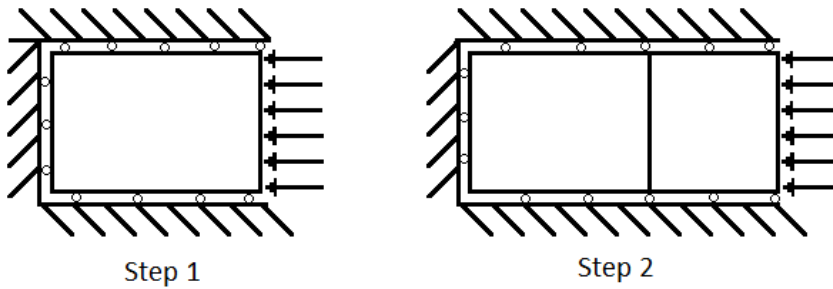

[The solution of the same problem in CAE Fidesys:](#)

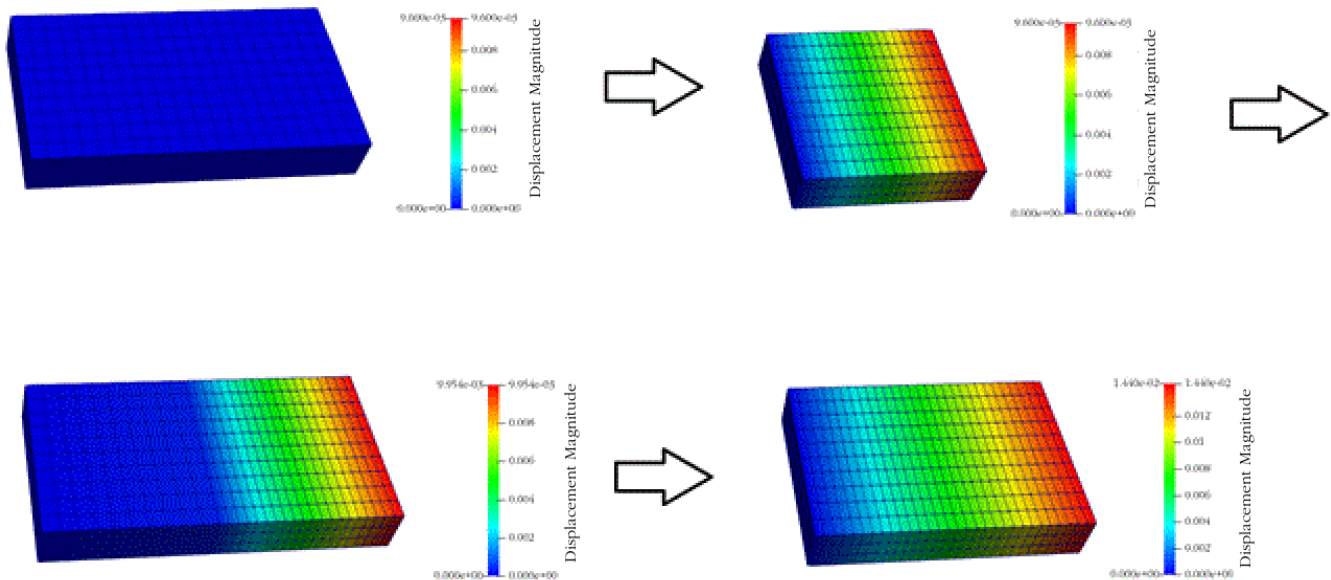

Detailed examples are given below in the Step-by-Step User Guide.

Spectral element method

It is a unique feature of *CAE Fidesys* that, in addition to the of finite element method (FEM) used by default, it enables calculations by spectral element method (SEM).

SEM brief description and advantages

Spectral element method (SEM) is a FEM modification where piecewise functions are used as basic functions consisting of high degree polynomials.

The main advantages of SEM in comparison to FEM:

- 1) High computational speed as there is no need to solve the system of linear algebraic equations due to diagonal form of mass matrix. The latter is obtained by specific quadrature formula for volume integration.
- 2) High precision of solution approximation at coarse meshing (low number of elements). The solution error is estimated as

$$\| [u]_h - u_h \| \leq C(N),$$

where

$$C(N) = C_2 h^N \text{ for FEM}$$

and

$$C(N) = C_1 h^N e^{-N} \text{ for SEM.}$$

C_1 and C_2 are constants, h is a characteristic element size, N is an element order, u_h is a numerical solution, $[u]_h$ is an exact solution in mesh nodes.

- 3) Ability of effective paralleling for OpenMP, MPI and CUDA.

SEM is most effective for the dynamic analysis using an explicit time scheme.

Here are the results of classical problem of wave propagation in 2D plate (size 1x1).

To achieve the computational error 2% and less, it is necessary to generate one of the following meshes:

- a) 3-noded triangular mesh of 6 390 197 elements (characteristic element size is 4e-4)

b) 4-noded quadrilateral mesh of 1 640 961 elements (characteristic element size is $3e-3$)

c) coarse spectral element mesh with 4th element order (only 16 elements are required).

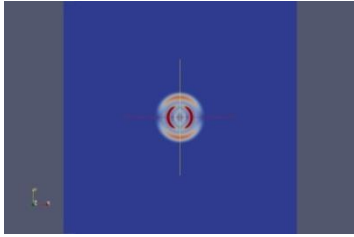

Fig.1. The distribution of the field of magnitude of displacement U across the plate at the time t_1

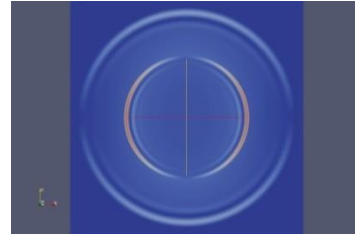
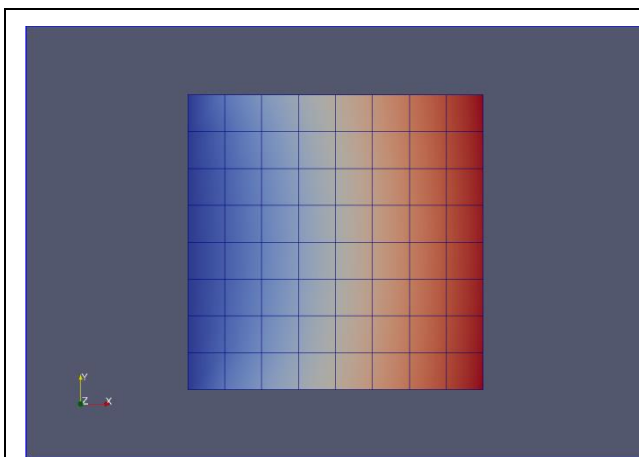
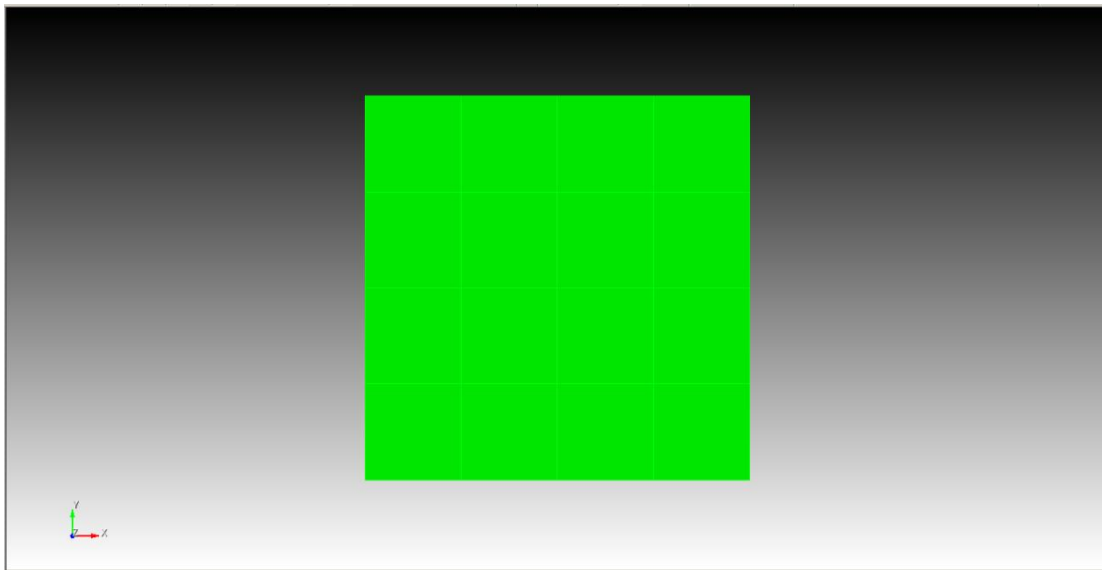
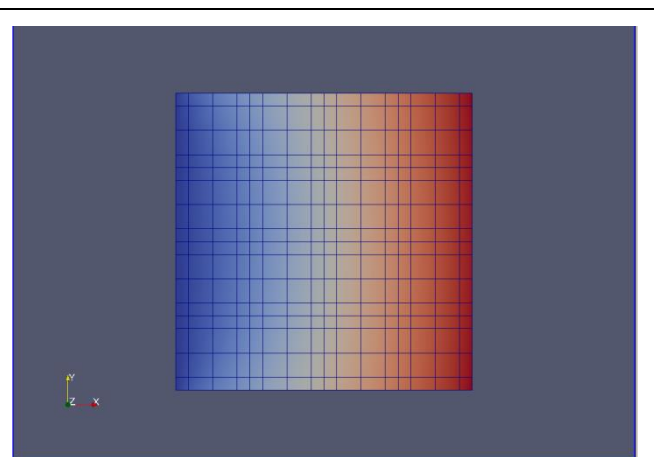

Fig.2. The distribution of the field of magnitude of displacement U across the plate at the time t_2

Here are the examples of computation results for different spectral element orders:



2nd spectral element order



4th spectral element order

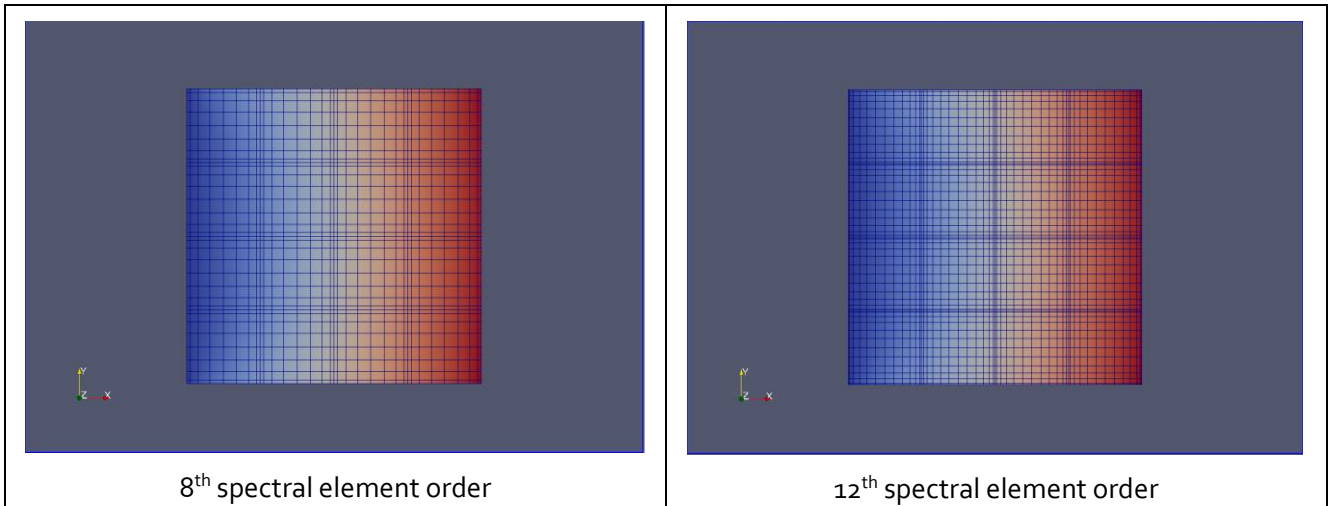

SEM Usage

In order to use the method of spectral elements instead of the finite element method to solve the problem, set the order of elements 3 and higher (except springs and sphere elements)::

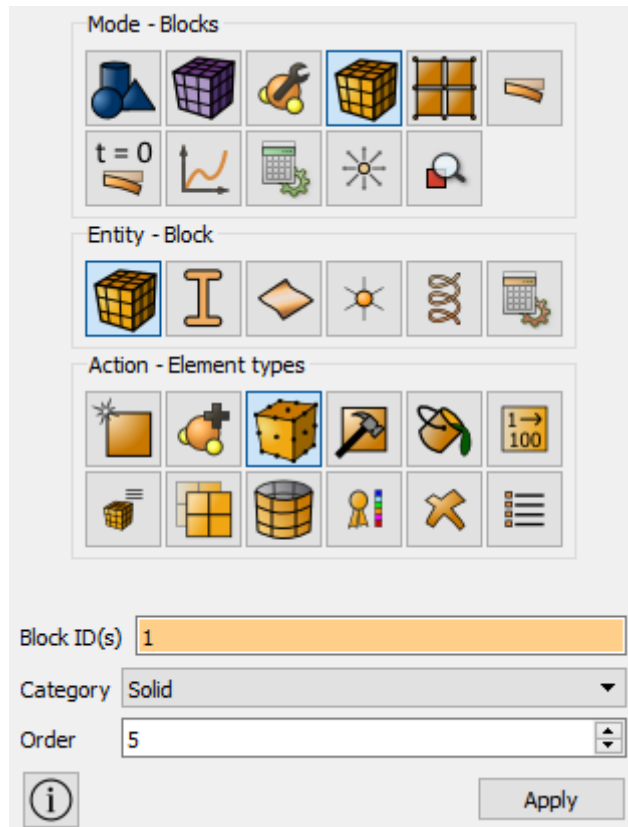

Parallel calculations on several computers using MPI technology

If you have a network of several computers with installed **CAE Fidesys** software MPI technology allows you to combine their computing capacity for parallel solution of the same problem.

MPI brief description and advantages

MPI technology currently represents a standard for parallel computing in distributed memory systems, i.e. those in which each processor has its own independent address space and communicates with the other processors via messages. MPI technology is more effective in solving problems with a large number of degrees of freedom because, on the one hand, it allows solving problems that do not fit in the computer memory and, on the other hand, large FEM or SEM problems require relatively low intensity of the messages exchange between the processors and thus they less load the network connection. This is particularly important for systems with distributed memory in which processors are connected by the common network with a capacity of 100 Mbit/s as if several computers in the office.

MPI implementation in CAE Fidesys

CAE Fidesys provides the ability to use MPI with the following types of calculations:

- Statics;
- Dynamics;
- Modal;
- Buckling.

Here are supported models to calculate via MPI:

- Elasticity;
- Elastoplasticity;
- Thermal conductivity;
- Thermoelasticity;
- Finite deformations;
- Pore Fluid Transfer.

MPI installation

Intel MPI installs and runs in conjunction with the installation of the **CAE Fidesys** software package. If the Intel MPI version has already been installed on your computer and you do not want to replace it, please contact **Fidesys** customer support for instructions on how to install and configure it.

In order to use when calculating the MPI necessary to put a tick **Use MPI** in the Toolbar in the General settings of the selected calculation type. You will then see a special menu **MPI Settings** to specify needed parameters.

In the pop-up MPI settings, select parallelization mode:

- a. Local – the calculation will be carried out on the local machine using a specified number of processors. The mode gives a gain in comparison to the calculations without MPI only for the local configuration with a large number of cores.
- b. Multiple hosts. In this mode, the calculation will be launched on several computers.

MPI local usage

In order to use MPI locally on a single computer, you need to register at first (see below). Then go to the MPI Settings Panel, tick **Local** and select the number of processors in a special window. After this, you can start the calculation, no additional settings for MPI local use is not required.

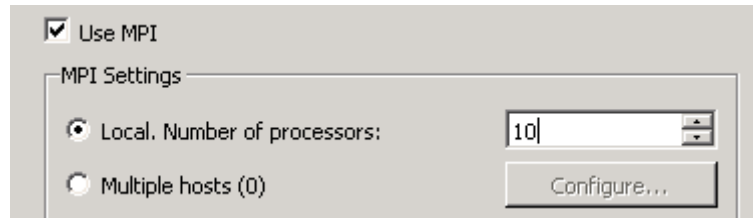

MPI usage on several nodes

Requirements for the correct operation

1. Make sure that the firewall settings on all computers allow correct operation of MPI.
2. It is recommended to disable the firewall on all computers involved in the parallel calculations.
3. **CAE Fidesys** should be installed on the same path on all computers. This path **cannot** be network.
4. The path to FidesysCalc must be the same on all computers involved in the parallel calculations.
5. The working directory (the directory where the file .pvd and file folder of the calculation results are written) should be available at all nodes on the same path which **can** be network. The user on whose behalf the calculation is carried out must also have write access to the work directory in all nodes. To find out which way is the working directory, you can go to the Menu **Tools** → **Options** → **Paths**, the string **Working Directory**. In other words, the calculation should be stored in a network folder, while the network path should be indicated in the save dialog:

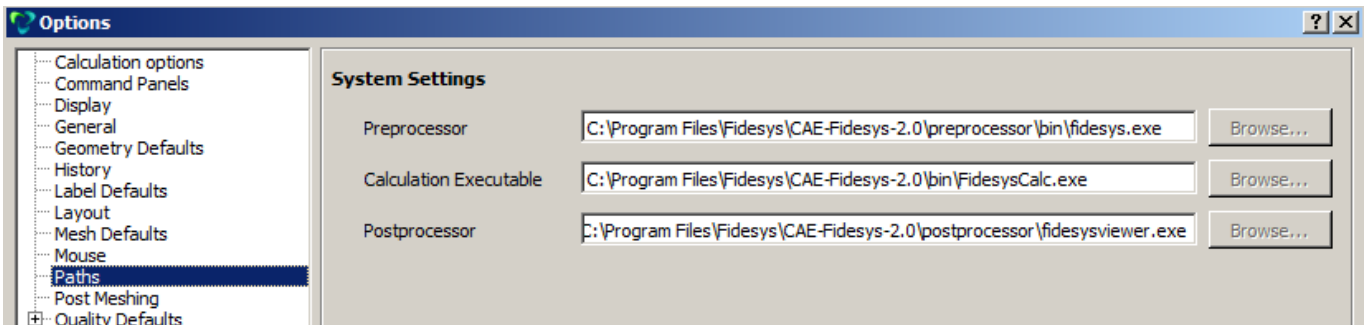

6. There are no special restrictions on the connection speed between the nodes but you should keep in mind that if the connection speed is very slow, the calculation using the MPI can take as much or more time than the calculation without MPI as all the time saved will be spent on the data exchange between nodes.
7. This software version has no limit on the number of used nodes.

MPI setting on several nodes

After making sure that all of the above requirements are met, go to the MPI settings panel (**Calculation Settings** – **Static** – **General** – **Use MPI**). Put a checkbox next to the point **Multiple hosts** and click **Configure...**:

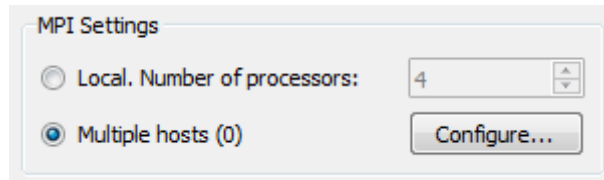

You will see the following window:

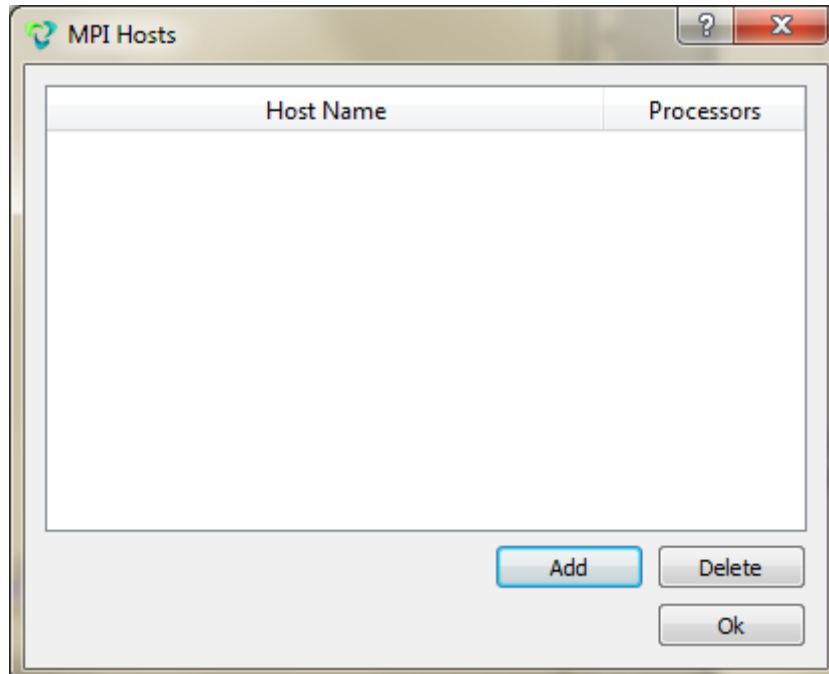

Using **Add** and **Delete**, add to the list all the hosts you use, in the field Name write the host name in the network, in the field Processors indicate the number of processors used on the host. After completing the list, click **Ok**.

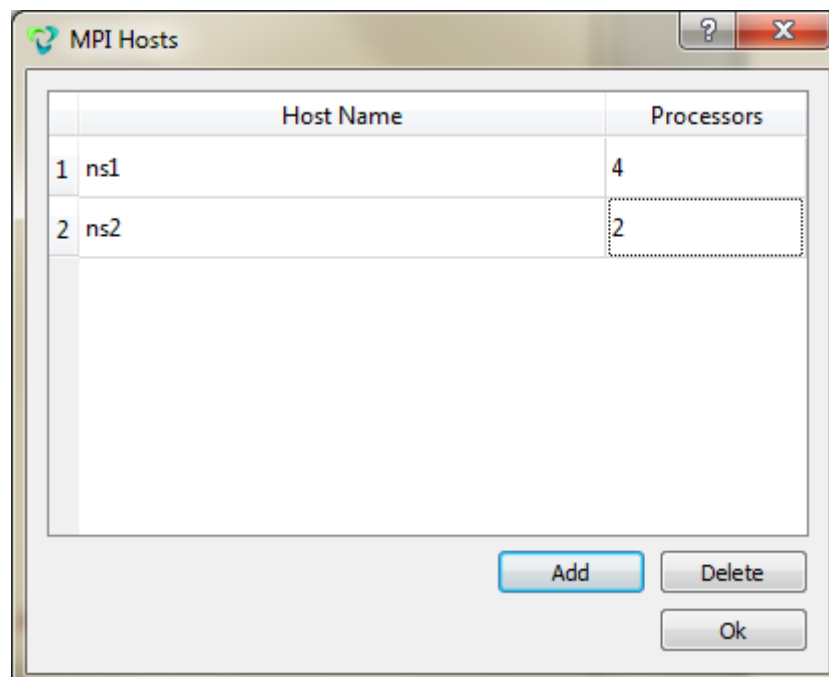

After this, the number of hosts indicated in parentheses after the words Multiple hosts on the MPI settings panel should change:

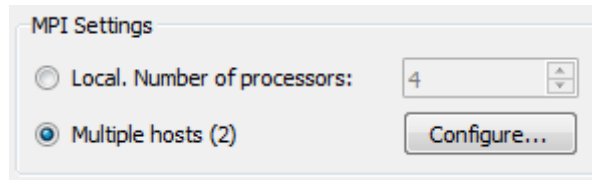

Now you can specify other calculation settings and run it as usual; it will be carried out using the MPI on several nodes.

Registration before the first usage

If you try to carry out the calculation using MPI for the first time, you should see error window.

In order to register (without this step, the calculation is impossible), click **Yes**. You will see Windows terminal window which you will need to enter Windows username and password on behalf of which you launch the calculation using MPI.

You can also register by running the Windows terminal window from the panel "Start" (to do this, type in the search box «cmd») and by typing the command **mpiexec –register** in the window. Then you need to enter login and password in the same way as when registering using a pop-up Fidesys window.

If you have already registered the service, tick **Do not show this message again**.



For more information, see the **Intel MPI** documentation.

Overview of the calculation results

After performing the calculation using MPI, in the **Fidesys Viewer** postprocessor the new field **MPI Nodes** should appear that characterizes a partition on the specified earlier processors:

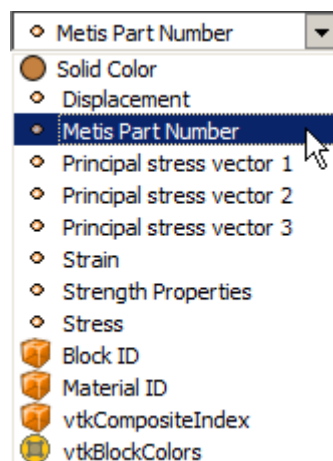

Calculation example using MPI

You can see an example of calculation on two computers in the picture below. Parts that are calculated on various computers are presented in different colors.

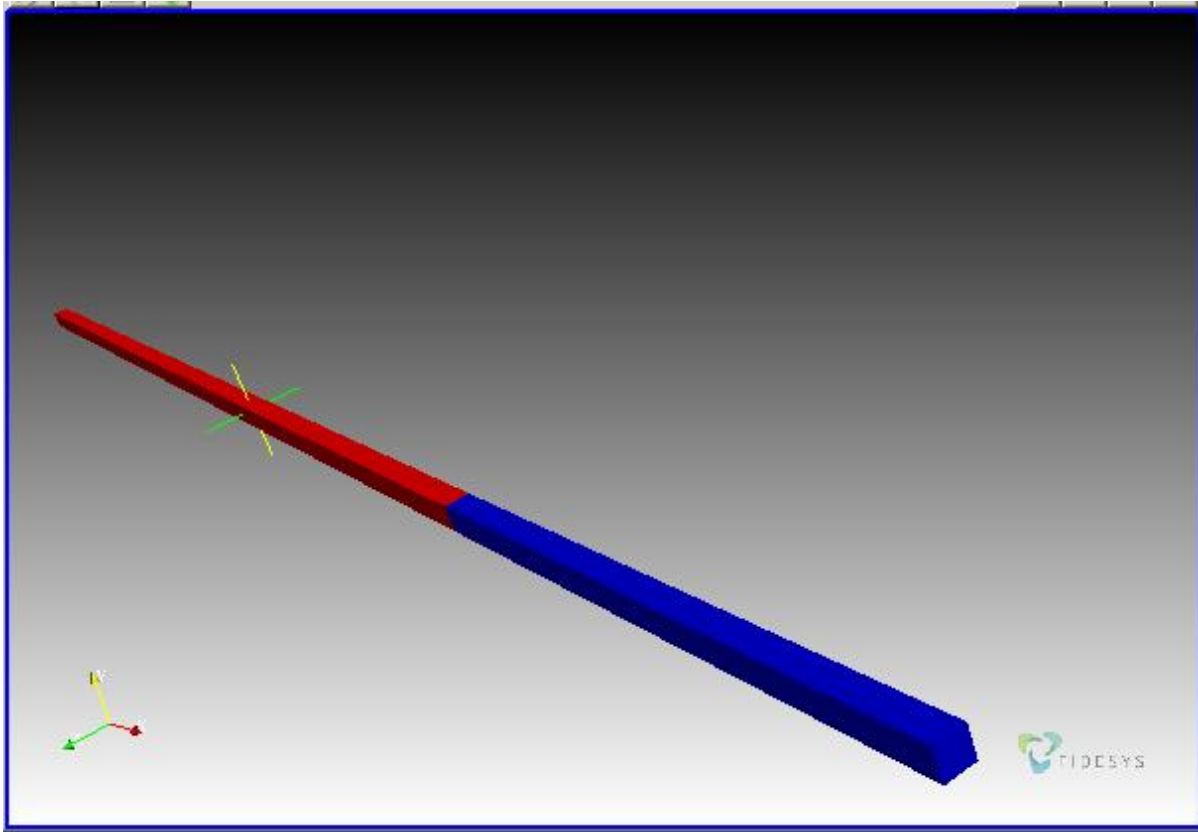

Heterogeneous materials effective property calculation

In *CAE Fidesys* there is the possibility of calculating the effective properties of an heterogeneous material, for example, composite or porous material.

Geometry of the model for effective property calculation

A representative volume is a geometric model for calculating the effective properties of the material of nonperiodic structures, i.e. the volume by which behavior under deformation you can be judged on the behavior of the material in general. This typically means that the size of the representative volume should be approximately an order of magnitude greater than the characteristic pore size or the inclusions in the material. A periodicity cell may be a geometric model for the calculation of the effective properties of periodic structure material.

It is important that the geometric model for the calculation of the effective properties must always be a fragment of material «cut» out of it in the form of a **rectangular parallelepiped**. When calculating, this fragment should be positioned so that the edges of the parallelepiped were strictly parallel to the coordinate planes. Automatic checking of the model form and position to calculate the effective properties is not provided, this should be controlled by the User – otherwise the calculation can pass and be correctly completed but the results will be misleading.

Examples of valid models for the calculation of the effective properties are shown below. If the tested material is solid (left), then the model for calculating its effective properties must be a solid rectangular parallelepiped with edges parallel to the coordinate planes. If the material contains pores or cavities, then the model for the calculation must contain cavities that may come to the surface (as shown on the right).

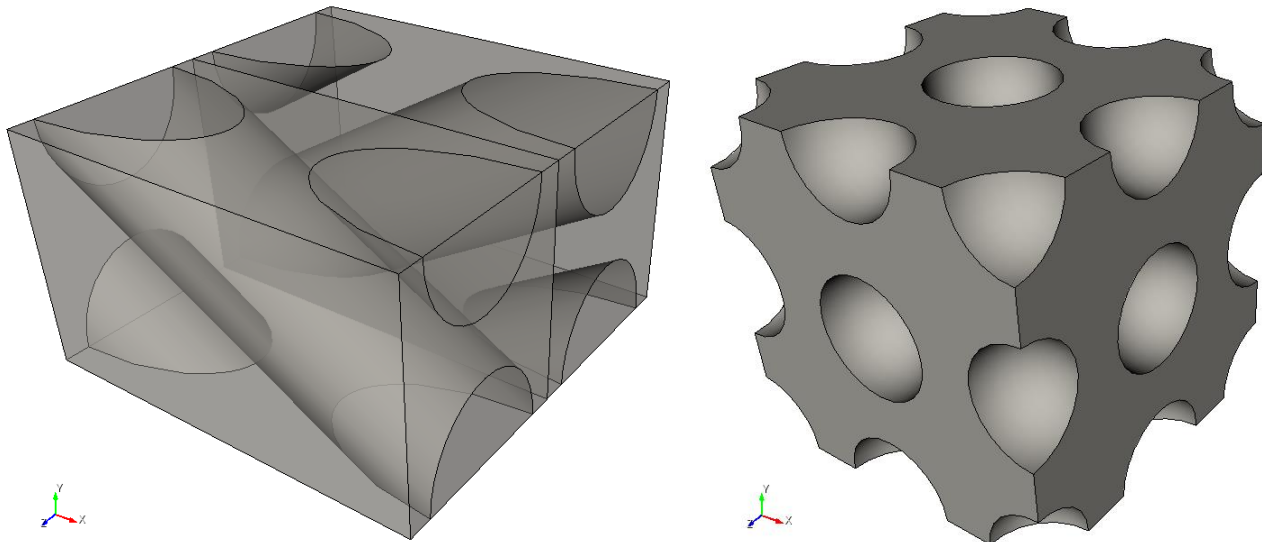

Generation of periodic cell geometry of some composite materials with periodic structure in **CAE Fidesys** can be performed automatically. In the geometry control mode, there is a button «Create Composite» as shown below.

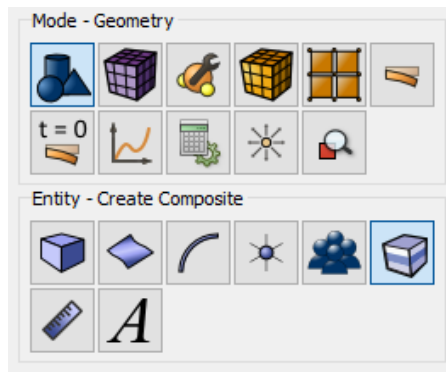

You can create periodicity cells of the following composite types

- Fiber-layered (two-layer) composite;
- single-layer fiber;
- single-layer fiber with shells;
- dispersed fiber reinforced (spherical inclusions);
- dispersed fiber reinforced with shells.

The user needs only to set the parameters of materials and click "Create" - the geometry will be generated automatically by means of the **CAE Fidesys** interface. It stands to reason, the user can also create the geometry for the calculation manually by means of the interface or to import; the most important thing is that the geometric model for the calculation of the effective properties is «cut» out of the material in form of the rectangular parallelepiped with edges parallel to the coordinate system in the **CAE Fidesys** interface.

Starting calculation

After creating the geometry, it is necessary to carry out the same actions as when calculating for static load: blocks creation, finite element mesh generation, material properties setting, etc, except for the boundary conditions application. To calculate the effective properties, it is unnecessary to apply the boundary conditions to the model: when calculating a number of boundary conditions types are automatically applied to the model sequentially; of the static load problem is solved for each type; results of all the problems are averaged and, as a result of averaging, the effective properties of the material are calculated. The user only needs to choose the type of boundary conditions: periodic or nonperiodic.

Periodic boundary conditions are preferred if the effective properties of the material of periodic structure are calculated and the periodicity cell serves as a model for the calculation. For example, if the material is a composite with matrix and inclusions, moreover, the stiffness of the inclusions is much higher than the one of the matrix and the inclusions are located on the surface of the model for the calculation – in this case it is necessary to use periodic conditions. If the effective properties of the material of irregular structure are studied and a representative volume is a model for the calculation, then the nonperiodic boundary conditions are preferred.

In *CAE Fidesys* it is the SLAE direct solver that is available to calculate the effective properties.

Element types

CAE Fidesys supports the effective properties calculation for the following existing finite elements:

- Solid elements (3D);
- Plane elements (2D).

Effective property calculation and its results

As mentioned, to calculate effective properties the model undergoes a series of strains. The following types of strains are used:

- tension (along each of the coordinate axes);
- shears (in each of the coordinate planes).

The strain magnitude is 0.2% for all types.

Effective properties are evaluated in the form of the generalized Hook's law:

$$\sigma_{ij} = C_{ijkl} \varepsilon_{kl}$$

The result of the calculation is effective elastic modules C_{ijkl} displayed to the command line and in the file called Cijkl.txt in the working directory. The modules are evaluated in the coordinate system where the calculation was carried out (which coordinate planes are parallel to the edges of calculation model).

Modules C_{ijkl} contain 21 independent constants – it is often more than it is necessary to describe effective properties of the tested heterogeneous material. That is why there is a possibility of the automatic conversion of

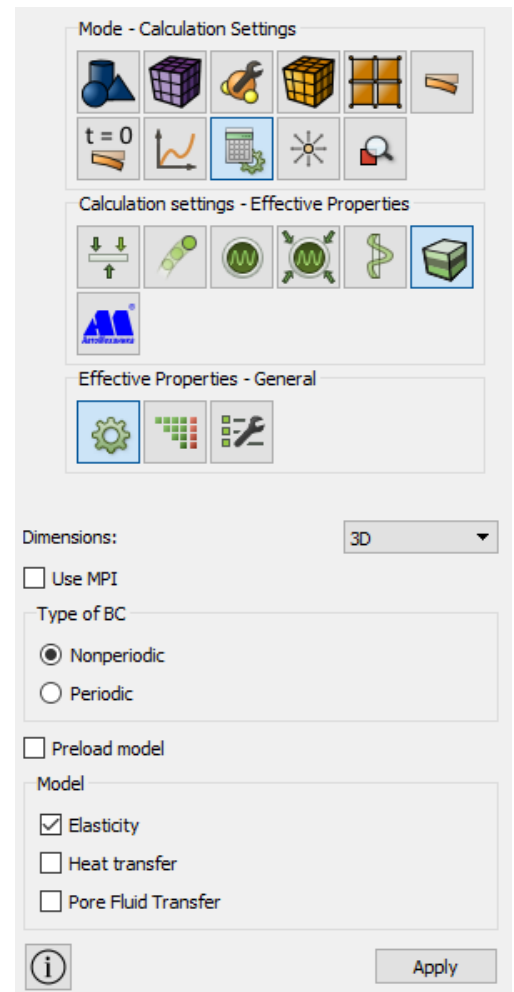

the obtained effective elastic modules into constants of orthotropic, transversally isotropic or isotropic material. After completing the calculation of the effective properties, the window «Process effective properties data» opens. In the window, obtained effective elastic modules C_{ijkl} are shown at the bottom right in the form of a symmetric matrix sized 6x6 (the matrix part below the main diagonal is not displayed by the symmetry).

When the calculation is complete, the window opens automatically. If the user closes it, it can be re-opened in the mode **Material > Effective properties**:

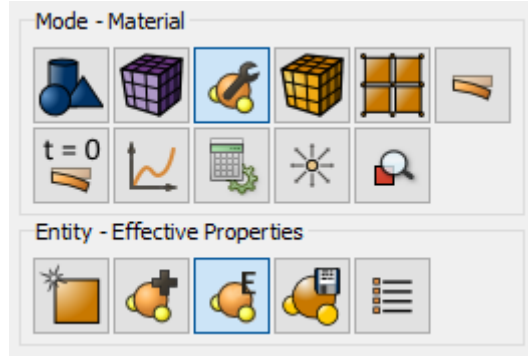

The user can assess whether the matrix with obtained C_{ijkl} to orthotropic materials with the satisfying tolerance. For the exact orthotropic material, the matrix should look as follows (where the letters X denote those components that can be nonzero).

$$\begin{pmatrix} X & X & X & 0 & 0 & 0 \\ & X & X & 0 & 0 & 0 \\ & & X & 0 & 0 & 0 \\ & & & X & 0 & 0 \\ & & & & X & 0 \\ & & & & & X \end{pmatrix}$$

However, since the components of the matrix are the result of numerical calculation of effective properties - they tend to contain some errors. If, from the user's point of view, the matrix corresponds to orthotropic materials with acceptable tolerance, select the «Orthotropic» type of material and click «Process Data» resulting in the fact that nine constants of orthotropic material will be counted.

If orthotropic constants in the X and Y will coincide with acceptable tolerance the user can select the type of material «Transversely isotropic» and click «Process data». Five constants of the transversally isotropic material will be calculated.

But if orthotropic constants do not depend on the direction then you can select the type of material «isotropic» and again click «Process data». Two constants of an isotropic material – Young's Modulus and Poisson's Ratio – will be calculated.

The window exterior «Process effective properties data» is shown in the figure below.

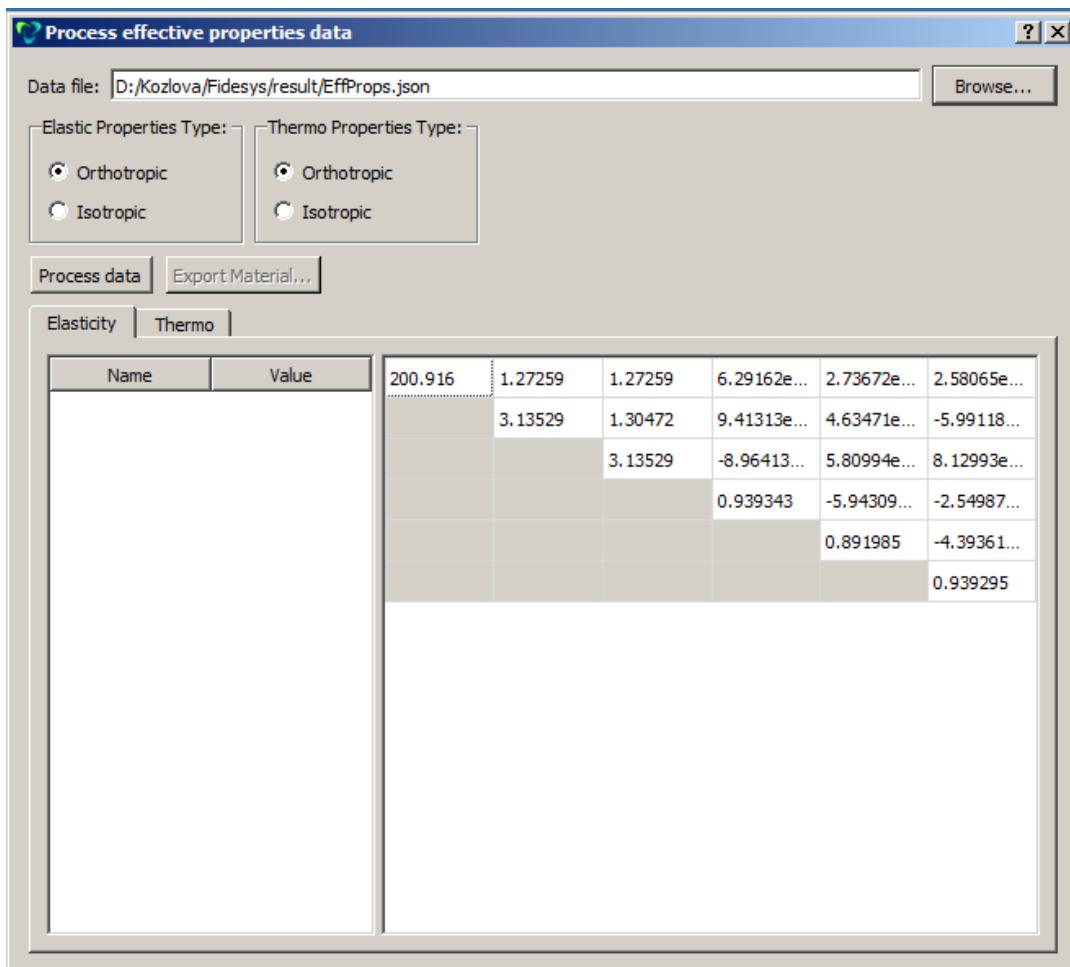

If the processed material constants satisfy the user, the option to export the material into the file XML is available in the same window. You must select a name for the effective material and the name of the XML file into which it will be exported. When you click «Export Material...», the material with the specified name and obtained effective properties are first created whereupon all other created materials are exported into an XML file with the specified name. You can then import these materials from the created file.

If heterogeneous material which efficient properties are investigated is orthotropic, transversely isotropic or isotropic from empirical considerations; and the calculation results do not correspond to that – you should try to refine the mesh or to choose a model for the calculation in another way.

SEG-Y format

SEG-Y is a sequential trail format designed for storing fully or partially processed seismic data.

<https://en.wikipedia.org/wiki/SEG-Y>

In order for the selected calculation results to be recorded in the SEG-Y format, it is necessary to place the Receivers on the model in the preprocessor (**Command Panel, Mode - Receivers, Operation - Create**).

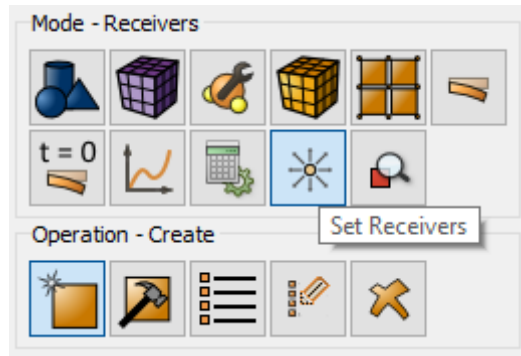

Select from the drop-down list the geometric entities that will be receivers.

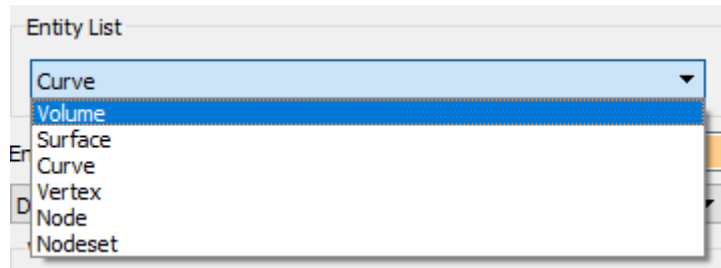

Specify which data fields to save in SEG-Y format.

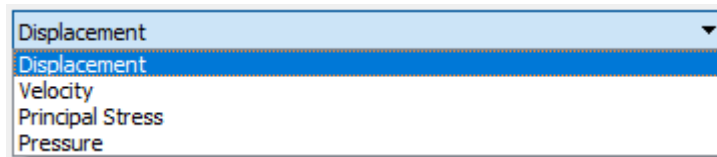

Installed receiver lines are displayed in the Tree on the left in the Results Settings section.

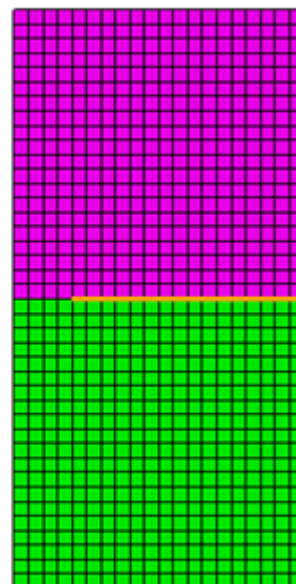
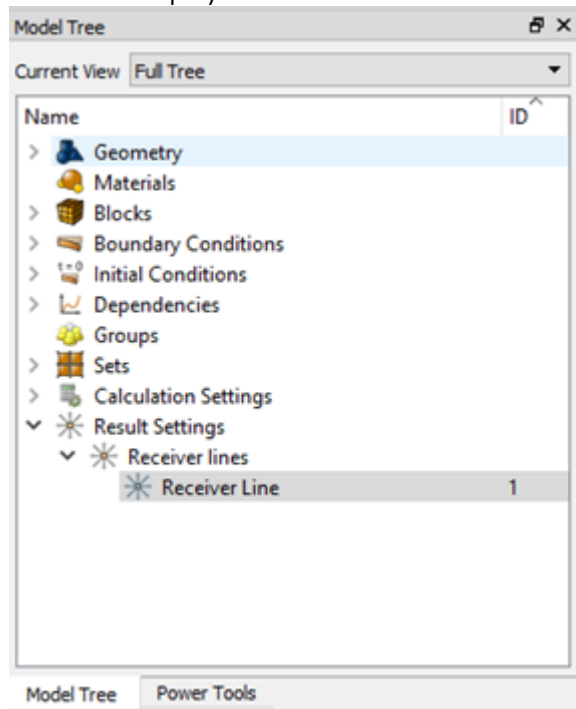

Viewing data in SEG-Y format is possible in the **CAE Fidesys** Viewer postprocessor, and you need to open the file with the .sgy extension.

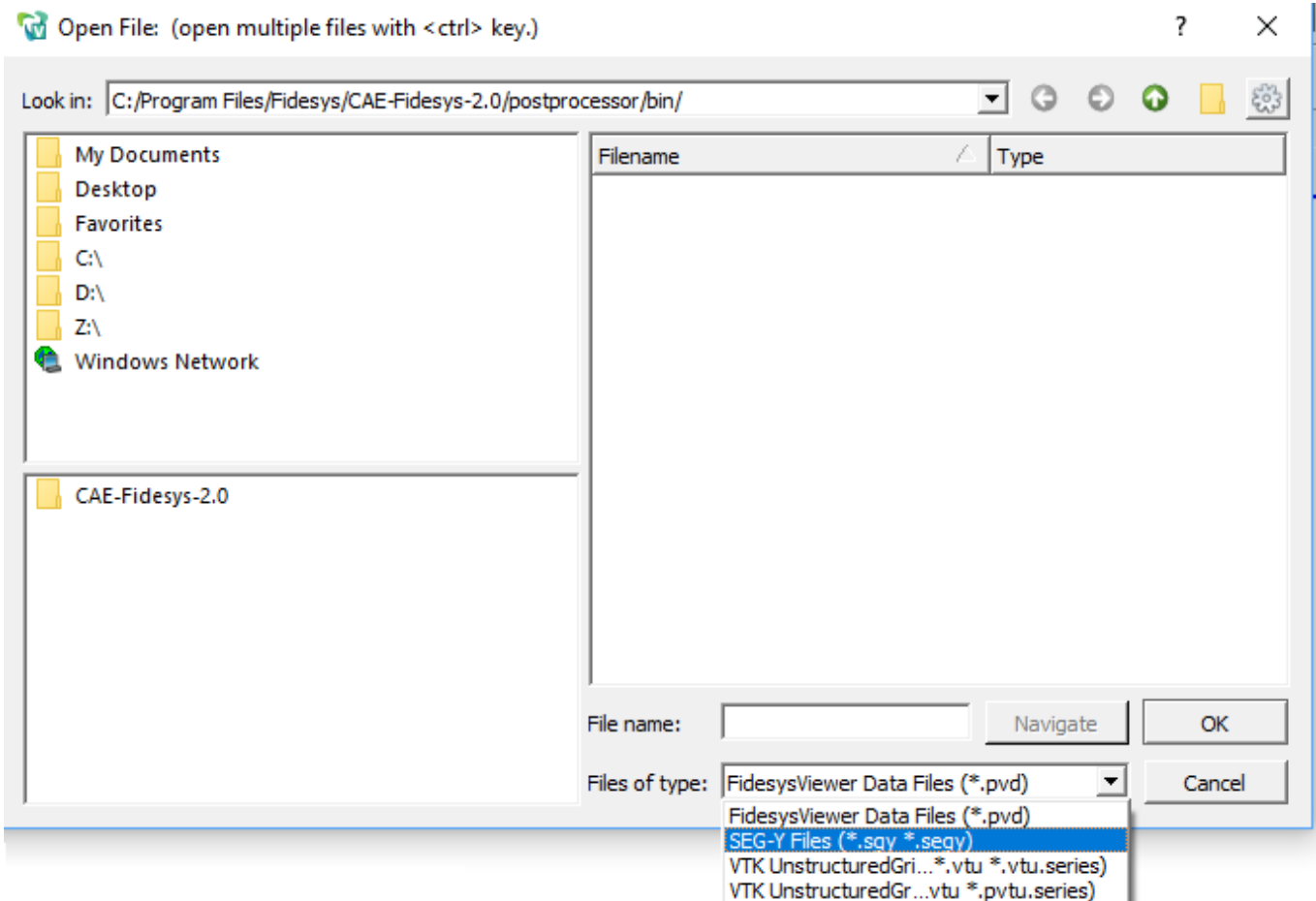

In Fidesys Viewer, it is possible to select the required subregions of the model using the Slice / Clip filters (**Menu - Filters - Alphabetical Index - Slice**)

[An example of the resulting SEG-Y file](#) for V_y speed in CAE Fidesys:



Features of writing data to the *.sgy file

- All data in the file header, with the exception of the results themselves, are written in integer form.
- The time step (recording step) is recorded in microseconds.
- The coordinates of the receiver are recorded in meters (If the distance between receivers is less than one meter, then the coordinates of the paths may coincide, and the wave pattern may be incorrect).
- Inline number coincides with the id of the node in which it is specified, the Crossline number matches the line number of the receivers.

Results Visualization and Postprocessing

Fidesys Viewer at a glance

The program **Fidesys Viewer** is used for visualization and analysis of the obtained results:

- Visualization of vector and tensor fields;
- Graph;
- Time dependency analysis;
- SEG-Y files.

Fidesys Viewer is included into the package **CAE Fidesys** and does not require individual installation. To use **Fidesys Viewer**, the license is not required: the results of calculations obtained by using the **CAE Fidesys** preprocessor are available for viewing in **Fidesys Viewer** even after the expiration of the license.

Main Window

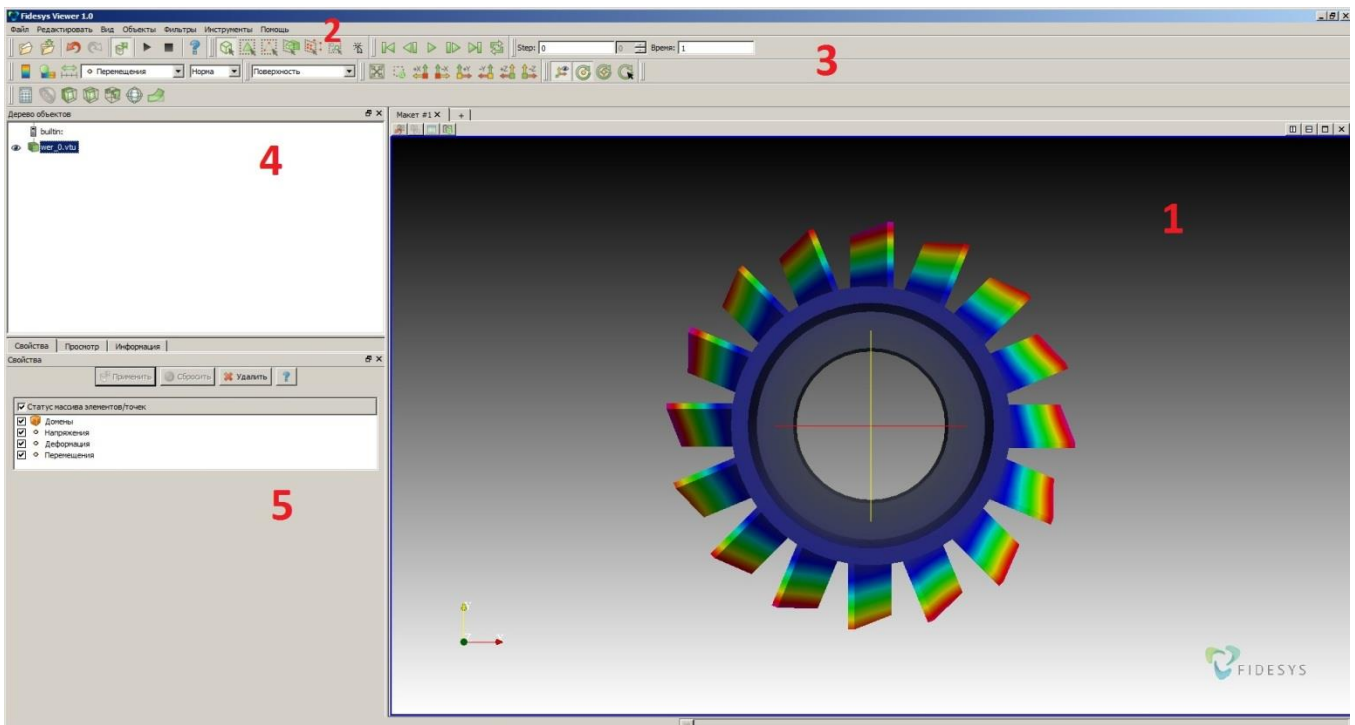

Workbench (1) displays the model and visual effects.

Main Menu (2) includes standard operations for working with files and projects, managing the visualization modes, panel display settings, filters, tools, and help available in the drop-down lists of the menu.

Toolbar (3) comprises the buttons for calling the most frequently used commands while working with the program.

Pipeline Browser (4) includes the opened models and filters applied to them.

Properties Page (5) displays the properties of the selected object in the Workbench or in the Pipeline Browser.

Additional panels can be shown or hidden in the menu **View**.

Basics of the program

Fidesys Viewer allows you to view and analyze the results. Viewing and analysis are performed using multiple filters you can select the item **View** in the menu. Some of them are described below.

Display on the data field and legend model

Fields and components of display can be selected in the Toolbar:



You can also see the Color Map by clicking  in the Toolbar.

Selection

In order to select points or cells, use the following buttons in the Toolbar:



On-screen information display

Numerical results for the data fields can be viewed in the tab **Information**. If the entire model is in focus, the fields of the tab **Information** contain a range of data – from minimum to maximum value.

The values in points can be found using the filter Probe Location (**Filters** → **Alphabetical** → **Probe Location**). Then you must specify the viewing point coordinates. After applying the filter, data field values are displayed only for the specified point in the tab **Information**.



To view the numerical results for the selected points is also possible by clicking **Point Information** on the Toolbar.

The values in the points/nodes/elements can be identified and viewed by using **Selection Inspector** (**View** → **Selection Inspector**).

Overview of the strained model

To view the strained model, select **Filters** → **Alphabetical** → **Warp By Vector**. In the Properties tab, you can select the display scale.



To quickly access the filter, click **Warp By Vector** on the top panel.

Spherical/cylindrical coordinate systems

To receive data from the spherical or cylindrical coordinate systems, select **Filters** → **Alphabetical** → **Coordinate systems**. Next, select the data field that you want to represent in new coordinates. After applying the filter, a new data field will appear in the tab Information, for example, Stress (spher.).

Graphing along straight line

To graph along a straight line, select **Filters** → **Alphabetical** → **Graph along a straight line**.

Specify coordinates of the beginning and end of the line. In the tab **View**, select the appropriate data field to display in the graph.

Graphing along curves

To graph along a curve, select nodes (see par. Selection) for which graph will be plotted. Next, use **Filters** → **Alphabetical** → **Extract selected** and then **Filters** → **Alphabetical** → **Show data**.

Graphing in time dependency

To plot a time dependency graph, you should allocate points of interest through the Allocation Inspector or by the button **Select points** in the standard string and then apply the filter **Filters** → **Alphabetical** → **Plot selection over time**.

Estimation of the mesh quality

To estimate the mesh quality, select **View** → **Filters** → **Alphabetical** → **Mesh Quality**. Specify the necessary settings in the tab **Properties**. After applying the filter, the new fields which analysis allows concluding about the mesh quality will appear in the tab **Information**.

Slice

To view the model slice, select **Filters** → **Alphabetical** → **Slice**. Specify the normal or the direction in which you want to make the slice.

Cross section

To view the model cross section, select **Filters** → **Alphabetical** → **Cross section**. Specify the normal or the direction in which you want to make the slice.

Beam and shell 3D-display



To view beams and shells in 3D in the **Fidesys Viewer** postprocessor, you can click on the button **3D** in the standard string.

Margin of Safety

To view the model cross section, select **Filters** → **Alphabetical** → **Margin Of Safety**. If the ultimate strength and yield strength were not specified when preprocessing, you should set them in the tab **Properties**. Margin of safety is calculated by the first theory of strength, energy theory, Tresca theory, Mohr's theory of failure, Pisarenko-Lebedev theory. Obtained values can be viewed in the tab **Information** in the new field **Margin Of Safety**. The first component of the field is the margin of safety by the first theory of strength; the second is the margin of safety by the energy theory, etc.

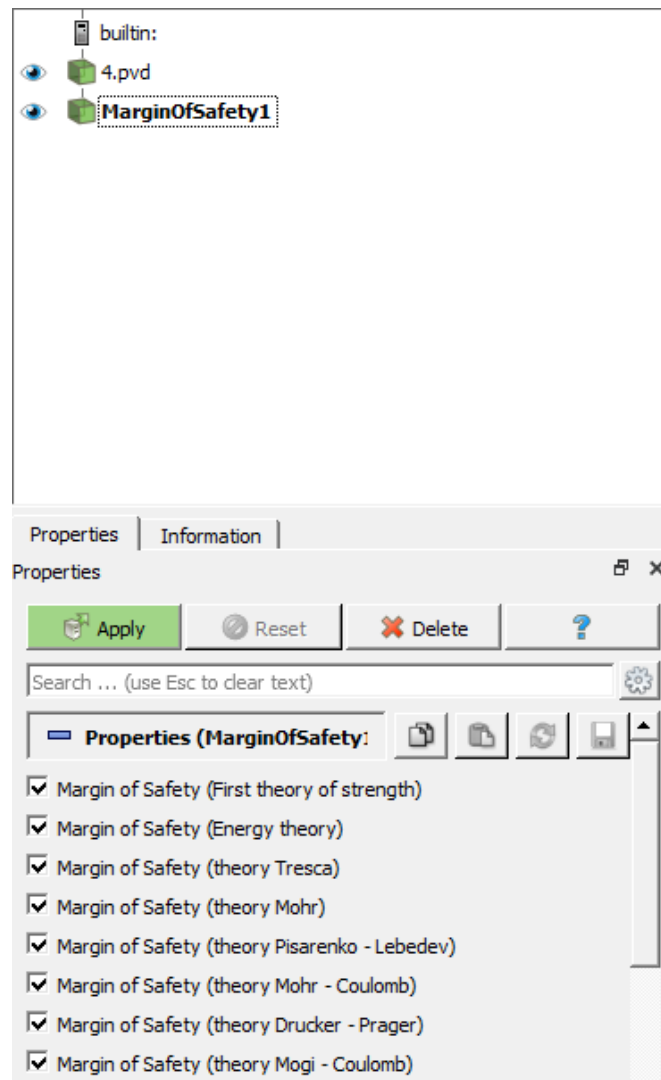

Harmonic analysis

To plot the frequency dependencies after performing a calculation using harmonic analysis, select **Filters** → **Index** → **Harmonic Analysis**. Specify the node number, the characteristics of which will be presented on the graph.

Data saving

To get numerical values of the obtained results, save the data in .csv format. Click **Ctrl+S** or select **File** → **Save** to do this. The saved file is an ordinary table of numerical data which can be opened in any text editor.

For dynamic problems, saving the model variation under deformation is available. Select **File** → **Save Animation** to do this.

Step-by-Step User Guide

Solving any problem using **CAE FIDESYS** package includes 6 basic steps:

- Model generating
- Meshing
- Setting boundary conditions
- Setting the material
- Starting calculation
- Results analysis

See some examples with step-by-step guide below.

Static analysis (3D)

NAFEMS test "Thick Plate Pressure", Test No LE10, Date/Issue 1990-06-15/2.

The problem of static load of a plate is being solved.

The pictures below represent a geometric model of the problem:

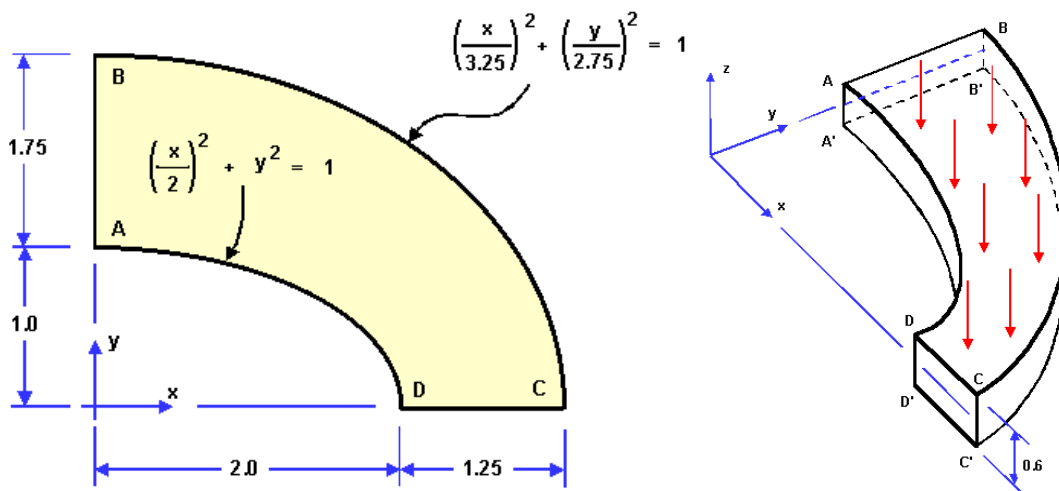

Displacements along the normal to the sides are constrained in the side slices of the plate. All of the points of the outer curvilinear surface are fixed in the XY plane. The outer curvilinear surface is fixed along the middle line of displacements along Z axis. The pressure to the upper side is 1 MPa. The material parameters are $E = 210 \text{ hPa}$, $\nu = 0.3$.

Test pass criterion is the following: stress σ_{yy} at the point D is -5.38MPa to within 3%.

Geometry creation

1. Create the first elliptic cylinder.

Select volume geometry generation section on Command Panel (Mode — **Geometry**, Entity — **Volume**, Action — **Create**). Select **Cylinder** in the list of geometric elements. Specify the cylinder dimensions:

- Height: 0.6
- Cross section: Elliptical
- Major Radius: 2
- Minor Radius: 1

Click **Apply**.

2. Create the second elliptic cylinder.

Select volume geometry generation section on Command Panel (Mode — **Geometry**, Entity — **Volume**, Action — **Create**). Select **Cylinder** in the list of geometric elements. Specify the cylinder dimensions:

- Height: 0.6;
- Cross section: Elliptical;
- Major Radius: 3.25;
- Minor Radius: 2.75.

Click **Apply**.

As a result, two generated entities are displayed in the Model Tree (Volume 1 and Volume 2):

3. Subtract the first cylinder from the second one .

Select volume geometry generation section on Command Panel (Mode — **Geometry**, Entity — **Volume**, Action — **Boolean**). Select **Subtract** in the list of operations. Set the following parameters:

- A Volume ID(s): 1 (*the volumes to be subtracted*);
- B Volume ID(s): 2 (*volumes from which other volumes will be subtracted*);
- Imprint.

Click **Apply**.

As a result, only one volume is displayed in the Model Tree (Volume 2).

The screenshot displays the software's Command Panel in three stages:

- Mode - Geometry, Entity - Volume, Action - Create:** The 'Cylinder' tool is selected. Parameters are set to: Height: 0.6, Circular: , Elliptical: , Major Radius: 2, Minor Radius: 1. The 'Apply' button is highlighted.
- Mode - Geometry, Entity - Volume, Action - Boolean:** The 'Subtract' operation is selected. A diagram shows two overlapping circles, A and B, with an arrow pointing to the resulting shape after subtraction. Parameters are: A Volume ID(s): 2, B Volume ID(s): 1. The 'Keep Originals' checkbox is checked. Under 'Keep Originals', 'Keep B' is selected. The 'Imprint' checkbox is unchecked. The 'Apply' button is highlighted.

4. Leave a quarter of a volume (symmetry of the problem).

Select volume geometry generation section on Command Panel (Mode — **Geometry**, Entity — **Volume**, Action — **Webcut**). Select **Coordinate Plane** in the list of possible webcut types. Set the following parameters:

- Volume ID(s): 2 (the volume to be webcut);
- Webcut with: YZ Plane;
- Offset value: 0;

Click **Apply**.

Do the same for the ZX Plane:

- Volume ID(s): 2 (the volume to be webcut);
- Webcut with: ZX Plane;
- Offset value: 0;

Click **Apply**.

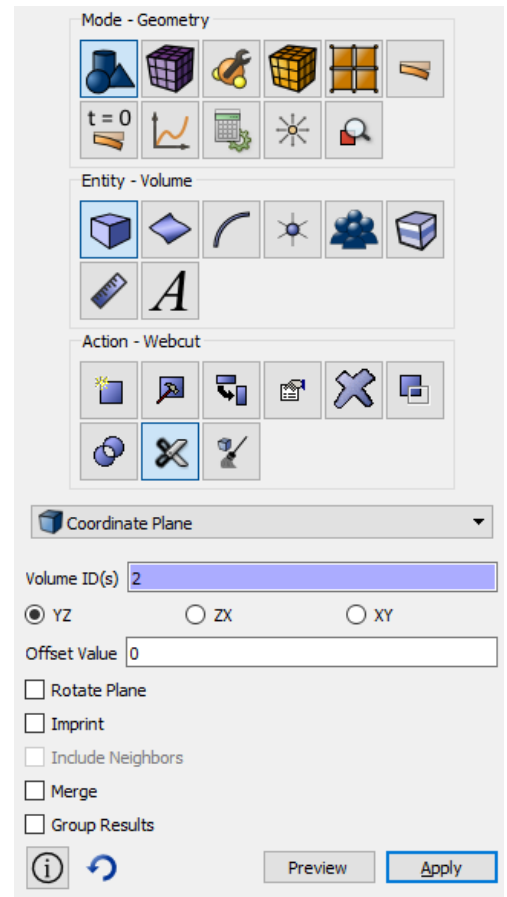

As a result, the original volume in the Model Tree is split into three (Volume 2, Volume 3 and Volume 4).

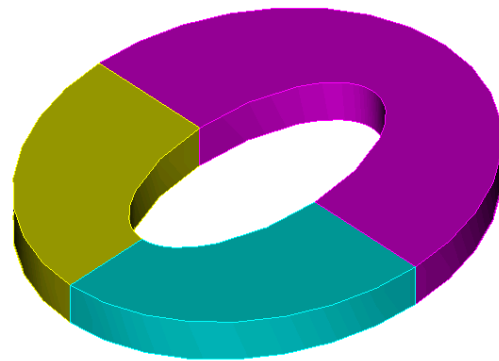
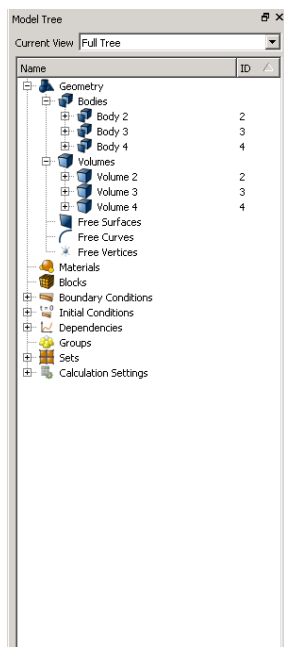

Delete the volumes 2 and 3. To do this, select these volumes in the Model Tree holding down Ctrl and click **Delete** in contextual menu. As a result, a quarter of the original volume is left (Volume 4).

- Split the outer curvilinear surface into two (it is necessary for restraining this surface from displacements along the middle line).

Select surface geometry modification section on Command Panel (Mode — **Geometry**, Entity — **Volume**, Action — **Webcut**). Set the following parameters:

- Coordinate plane;
- Volume ID(s): 4 (volume to be cut);
- Plane: XY;
- Offset value: 0;
- Put a checkmark in the **Merge** box.

Click **Apply**.

The result will be two volumes 4 and 5 glued to each other along the section plane:

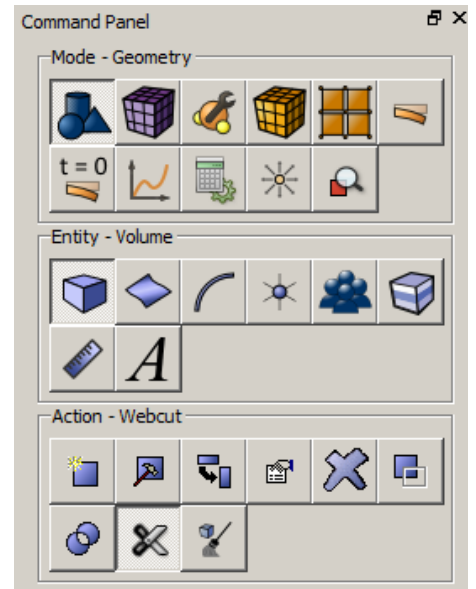
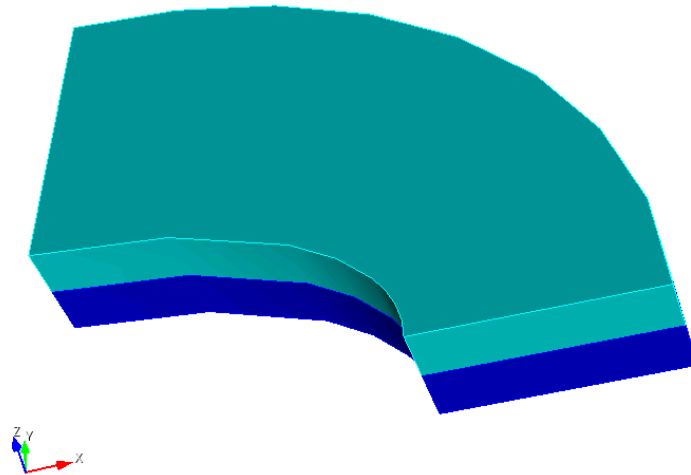

Meshing

- Select meshing on curves section on Command Panel (Mode — **Mesh**, Entity — **Curve**, Action — **Mesh**). Specify the parameters of mesh refinement:

- Select Curves: 43 44 45 46 (using space after each curve);
- Select the way of meshing: Equal;
- Select the checkbox Interval;
- Specify the number of intervals: 6

Click **Apply**. Click **Mesh**.

Select meshing on curves section on Command Panel (Mode — **Mesh**, Entity — **Curve**, Action — **Mesh**).

- Select Curves: 12 14 39 41 (using space after each curve);

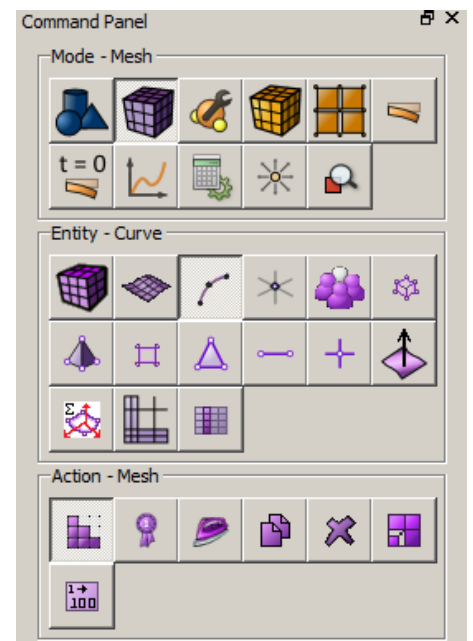

- Select the way of meshing: Equal;
- Select the checkbox Interval;
- Specify the number of intervals: 4.

Click **Apply**. Click **Apply Scheme**

On the command panel, select the mesh generation mode on the curves (Mode - **Mesh**, Entity - **Curve**, Action - **Mesh**)

- Select Curves: 51 53 61 62 (through spaces);
- Settings for Curve: Equal;
- Set the Interval flag;
- Indicate the number of interval: 1;

Click **Apply Size**.

Click **Mesh**.

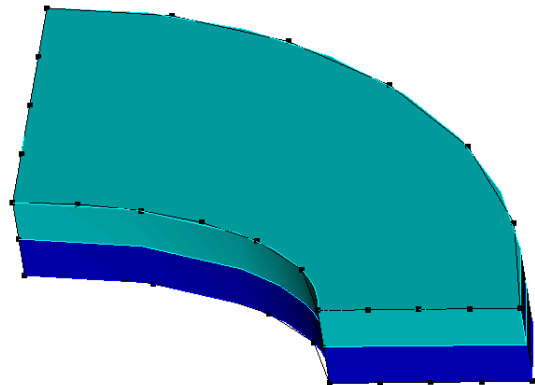

2. Select volume mesh generation section on Command Panel (Mode — **Mesh**, Entity — **Volume**, Action — **Mesh**).

- Select Volumes: 4 5 (or by the command **all**);
- Select Meshing Scheme: Map.

Click **Apply Scheme**.

Click **Mesh**.

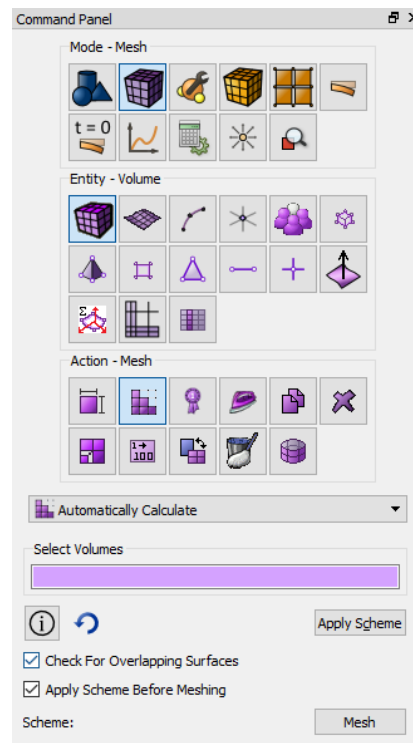
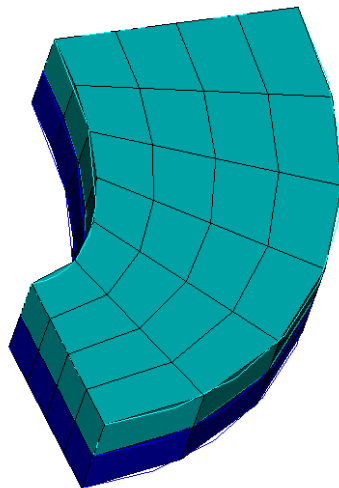

The resulting number of elements can be viewed in the Property Page by clicking on the inscription Volume 4 in the Model Tree on the left.

To view the mesh properties, you can follow these steps:

- Select the entire model
- Right-click on the model
- In the pop-up menu, select List Information – List Mesh Info
- Information on the mesh will be displayed in Command Line

The screenshot displays the CAE Fidesys interface. On the left, the **Model Tree** shows a hierarchy of objects including Geometry, Bodies, Volumes (Volume 4 and Volume 5), Free Surfaces, Free Curves, Free Vertices, Materials, Blocks, Boundary Conditions, Initial Conditions, Dependencies, Groups, Sets, and Calculation Settings. The **Properties Page** shows the mesh properties for the selected volume, with the **Mesh** section highlighted in red:

Property	Value
Type	Volume
ID	5
Name	Volume 5
IDless Signature	Volume (at 1.625 1.375 -0.1...
Is Merged	No
Is Virtual	No
Volume	1.63462
Mesh	
Is Meshed	Yes
Scheme	map
Elements	24
Nodes	70
Volume	1.61672

On the right, a 3D model of a curved part is shown with a teal mesh. Below the model is a coordinate system with X, Y, and Z axes. The **Command Line** at the bottom displays the **Mesh_Information** table, also highlighted in red:

Element_Type	Interior	Boundary	Total
Hex	24	0	24
Face	0	68	68
Edge	0	136	136
Node	0	70	70

The **Fidesys** logo and navigation buttons (Error, Commands, History) are visible at the bottom of the interface.

Setting boundary conditions

1. Fix one side (slice) along X axis.

Select Mode — **Boundary Conditions**, Entity — **Displacement**, Action — **Create** on Command Panel. Set the following parameters:

- System Assigned ID
- Entity List: Surface
- Entity ID(s): 33 40;
- Degrees of Freedom: X-Translation
- DOF Value: 0

Click **Apply**.

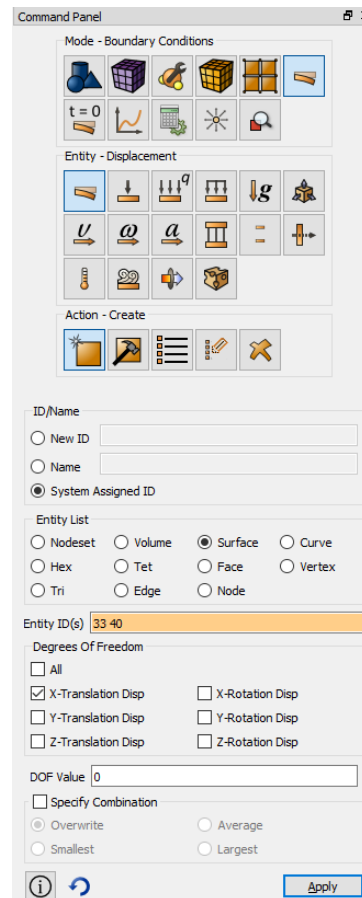
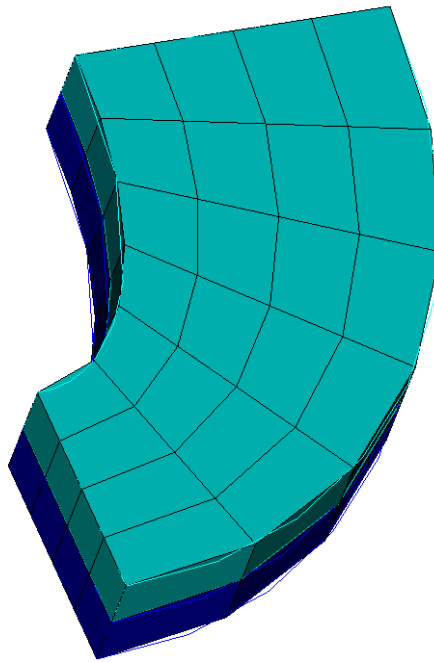

2. Fix one side (slice) along Y axis.

Select Mode — **Boundary Conditions**, Entity — **Displacement**, Action — **Create** on Command Panel. Set the following parameters:

- System Assigned ID
- Entity List: Surface
- Entity ID(s): 35 39;
- Degrees of Freedom: Y -Translation
- DOF Value: 0

Click **Apply**.

3. Fix the outer curvilinear surface along X and Y axes.

Select Mode — **Boundary Conditions**, Entity — **Displacement**, Action — **Create** on Command Panel. Set the following parameters:

- System Assigned ID
- Entity List: Surface
- Entity ID(s): 36 38;
- Degrees of Freedom: x-Translation and y-Translation
- DOF Value: 0

Click **Apply**.

4. Fix the middle line of the outer curvilinear side along Z axis.

Select Mode — **Boundary Conditions**, Entity — **Displacement**, Action — **Create** on Command Panel. Set the following parameters:

- System Assigned ID;
- Entity List: Curve;
- Entity ID(s): 50;
- Degrees of Freedom: z-Translation;
- DOF Value: 0.

Click **Apply**.

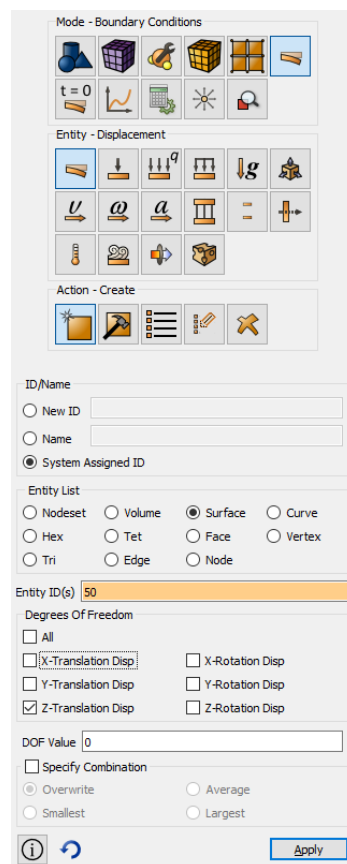
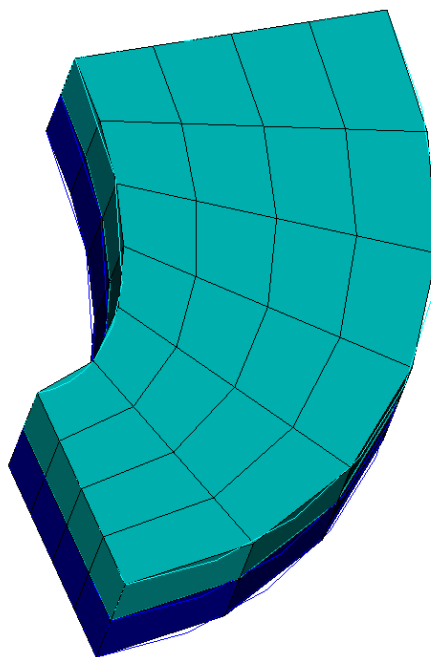

5. Apply pressure to the upper side.



Select Mode – **Boundary Conditions**, Entity – **Pressure**, Action – **Create**. Set the following parameters:

- System Assigned ID
- Entity List: Surface
- Entity ID(s): 31
- Magnitude Value: $1e6$ (an exponential number format using the Latin letter "e" is supported)

Click **Apply**.

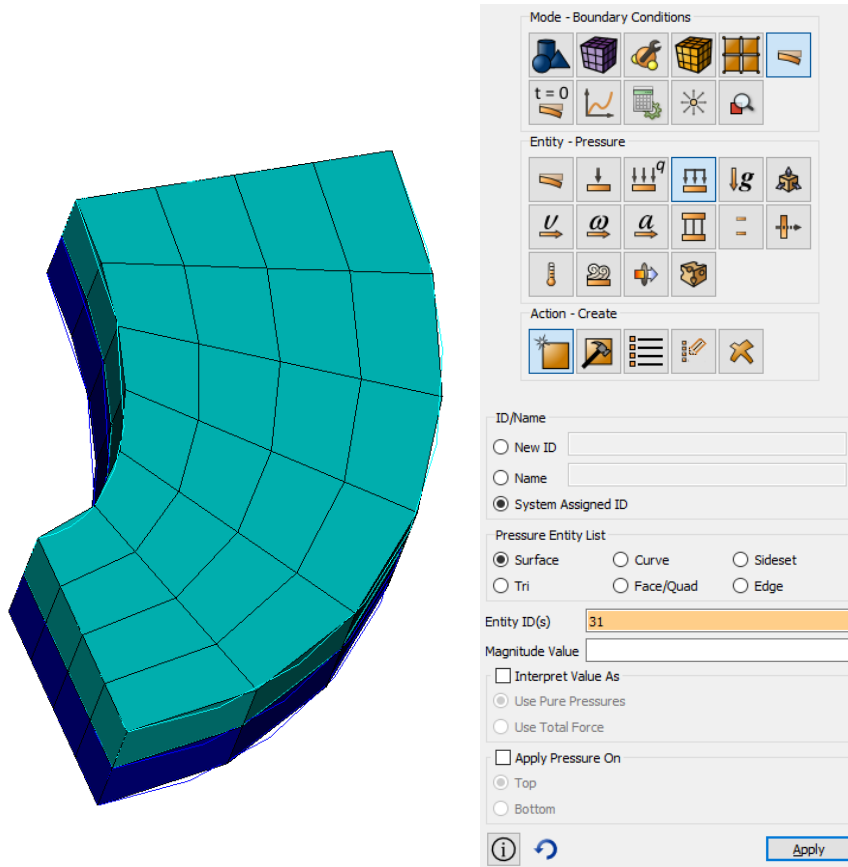

All applied boundary conditions must be displayed in the Model Tree on the left. In addition, the boundary conditions are available for editing from the Model Tree.

To view all the applied boundary conditions also click Show BC on the top panel.

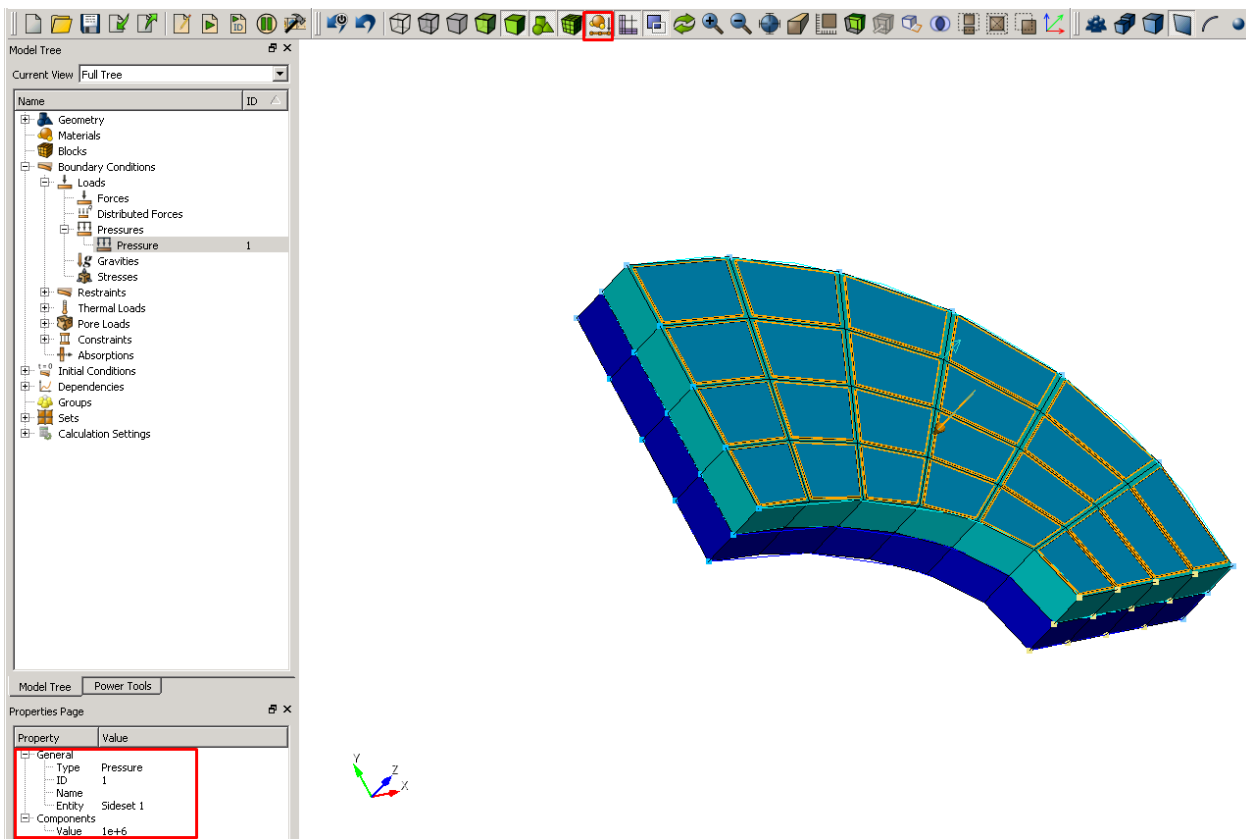

Setting material and element type

1. Create the material.

Select setting the material properties section on Command Panel (Mode — **Blocks**, Entity — **Block**, Action — **Set Material**).

In the Materials Management window that opens, in the second column, double-click on the caption. Enter the name of the material and write "Material 1". Press the ENTER key.

Next, using the "drag & drop" method, add the necessary characteristics from the left column to the Material Properties column.

In the left column, select Elasticity - Hooke Material. Select with the mouse the characteristic Young's modulus. Hold down the left mouse button and drag the label to Material Properties. Double-click in the Value field opposite the Young Module and enter the number 210e9.

Similarly, from the Hooke Material section add the Poisson Ratio 0.3.

Click **OK**.

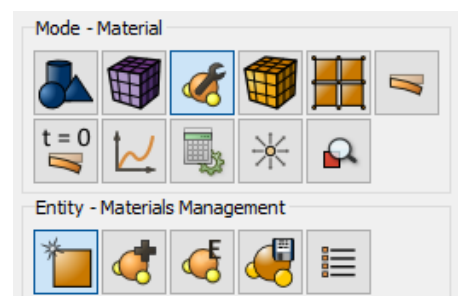

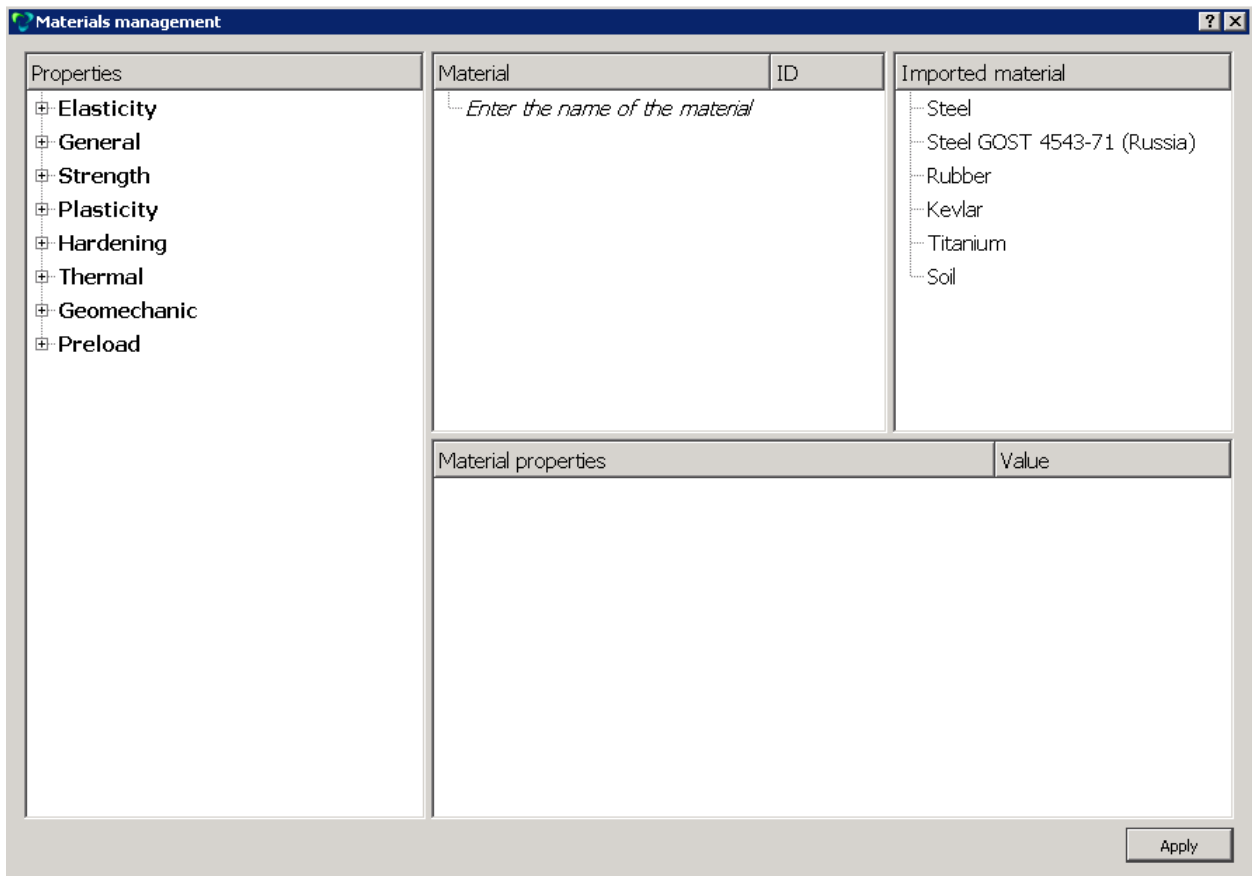

2. Create a block of one type of the material.

Select setting the material properties section on Command Panel (Mode — **Blocks**, Entity — **Block**, Action — **Add**). Set the following parameters:

- Block ID: 1;
- Entity list: Volume;
- Entity ID(s): 4 5 (or by the command **all**).

Click **Apply**.

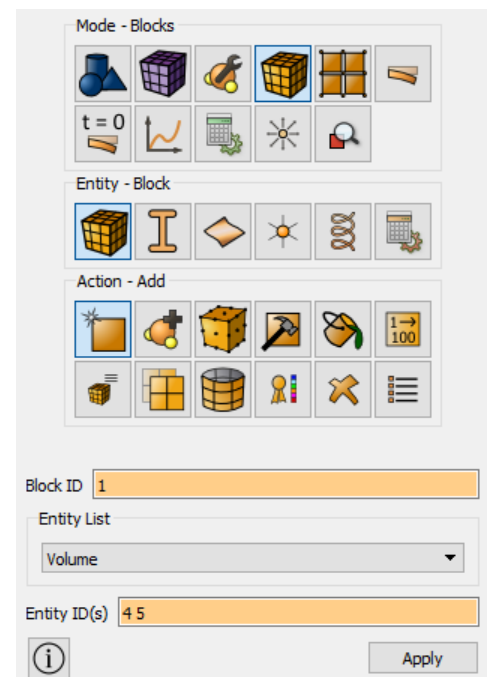

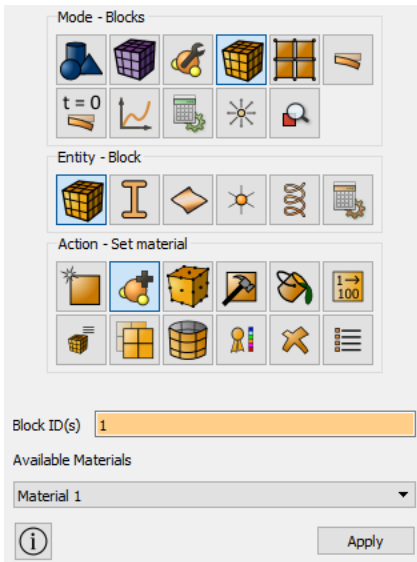

3. Assign the material to the block.

On the command panel, select the mode for setting material properties (Mode - **Blocks**, Entity - **Block**, Action - **Set Material**). Set the following parameters:

- Block ID (s): 1;
- Available materials: Material 1.

Click **Apply**.

Select material properties (Mode — **Blocks**, Entity — the following parameters:

- Block ID(s): 1;
- Category: Solid;
- Order: 1.

Click **Apply**.

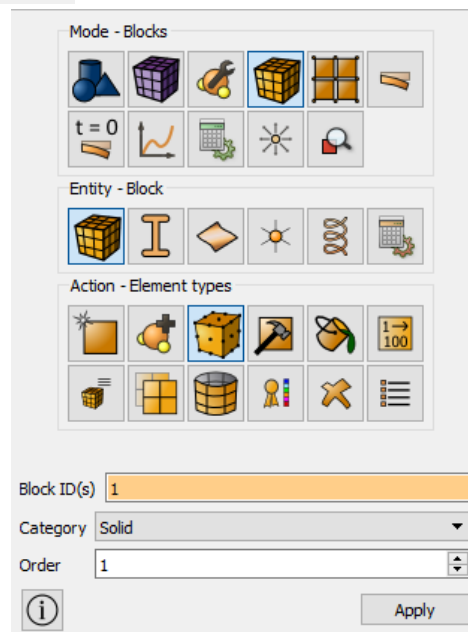

4. Assign the element type.

setting section on Command Panel **Block**, Action — **Element Types**). Set

Starting calculation

1. Set the type of the problem to be solved.

Select calculation settings section on Command Panel (Mode — **Calculation settings**, Calculation settings — **Static**, Static — **General**). Select:

- Dimension: 3D;
- Model: Elasticity.

Click **Apply**.

2. Set the solver settings.

Select calculation setting section on Command Panel (Mode — **Calculation settings**, Calculation settings — **Static**, Static — **Solver**). Select the solver method (direct or iterative) and set Convergence Parameters in case of choosing an iterative one. You can also leave all the settings by default.

Click **Apply**.

Click **Start Calculation**.

3. In a pop-up window select a folder to save the result and enter the file name.
4. If the calculation is finished successfully, you will see a message in the Console: "*Calculation finished successfully at <date> <time>*".

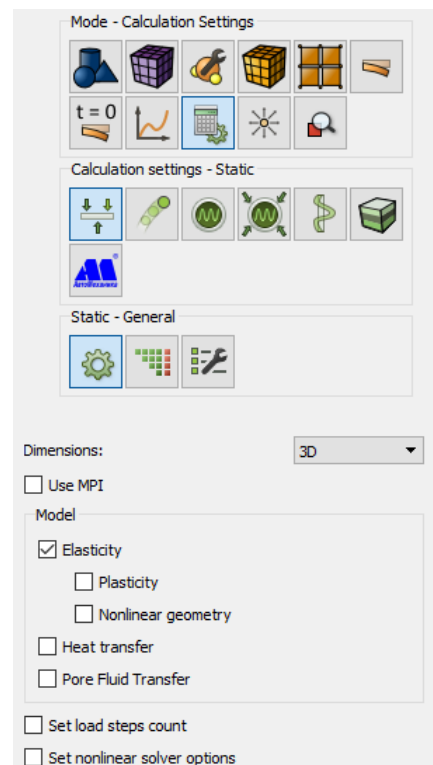

Results analysis

1. Open the file with the results. You can do this in one of the three ways.

- Press Ctrl+E.
- Select **Results** in the Main Menu. Click **Open last result**.
- Select **Results** on Command Panel (Mode – **Results**). Click **Open Results**.

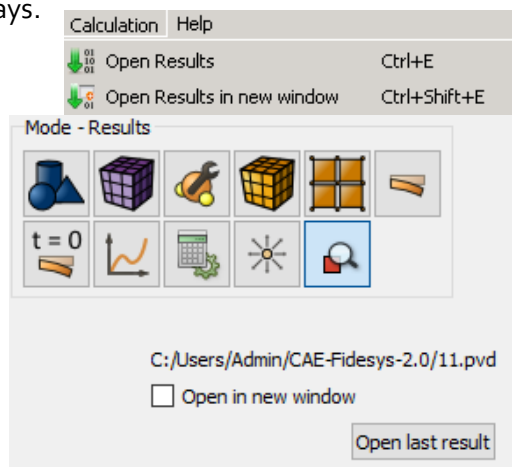

2. Display the component σ_{yy} of the stress field and the mesh on the model.

In **Fidesys Viewer** window set the following parameters on Toolbar:

- Representation Mode: Surface;
- Representation Field: Stress;
- Representation Component: YY.
- Surface with edges.

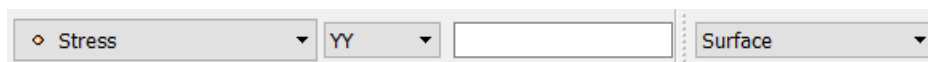

3. Select a point where you need to view the stress.

Select a point on the model by using **Select Points Through**.

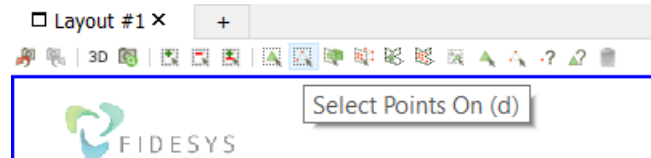

Select a point D on the upper side. From the main menu, select View – **Allocation Inspector**.

In **Allocation Inspector**, go to the tab **Point Tag** and select and click on the Stress line in the drop-down list.

As a result, Stress components at the point D is displayed at the picture.

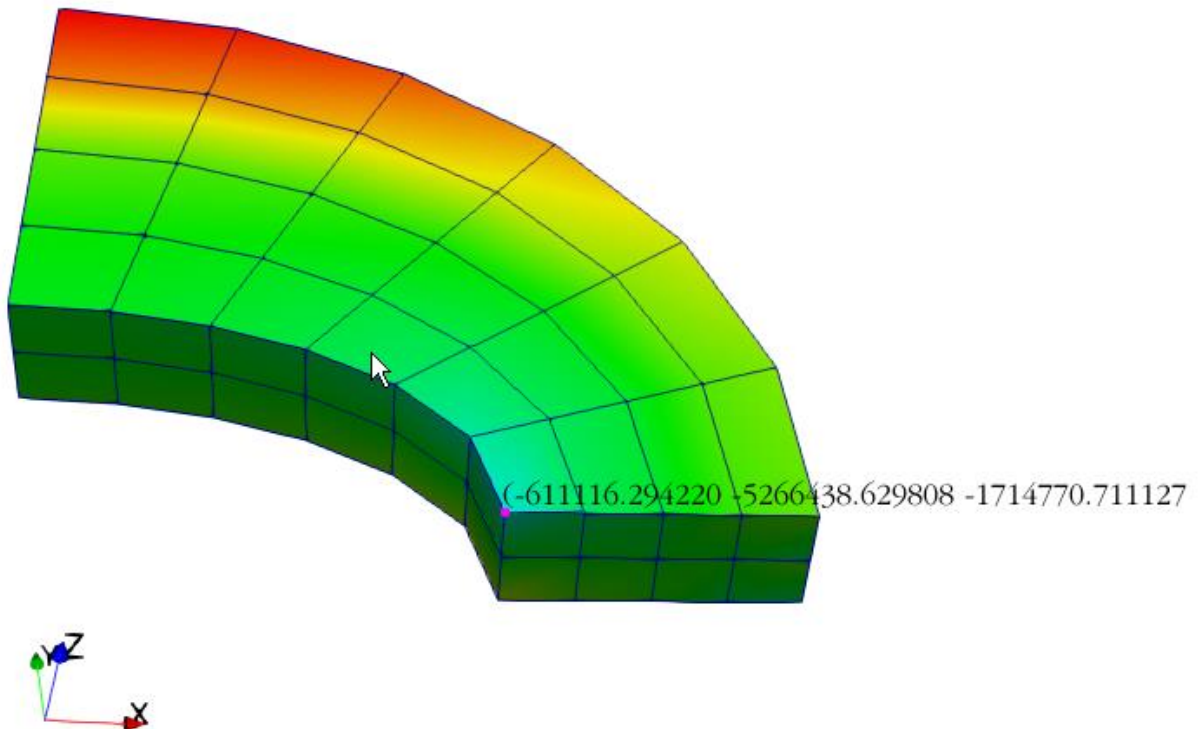
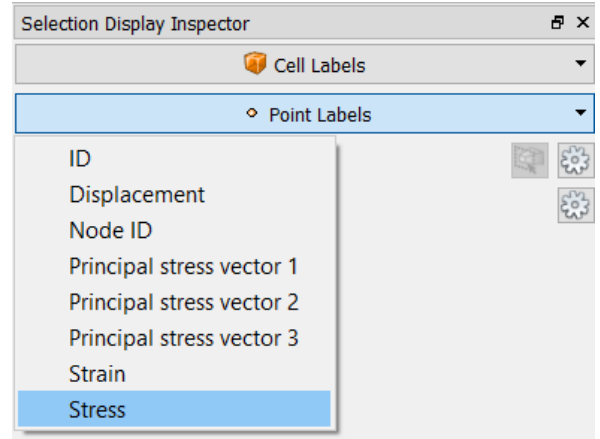

4. View a numerical value σ_{yy} at the selected point D.

The difference between the obtained value $-5.266e+06$ and the required one $-5.380e+06$ is 2.12%.

5. Download numerical data.

Select **File** → **Save Data** in the Main Menu or click **Ctrl+S**. Enter the file name (*.csv format), leave it by default. Click **OK**. The saved file is an ordinary table of numerical data which can be opened in any text editor.

6. You can see the way the body is deformed under the applied pressure.

Select the filter **Warp By Vector** to do this. Set the following parameters in the tab **Properties**: set the value to 5000 in the field **Scale Factor**.

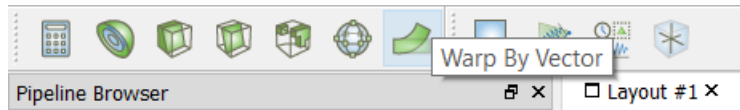

As a result, the deformed body is displayed at the picture. To see the original model, click near it in the Model Tree. The picture below shows the deformed (solid grey filling) and the original model (with the field of displacements distribution along Y axis).

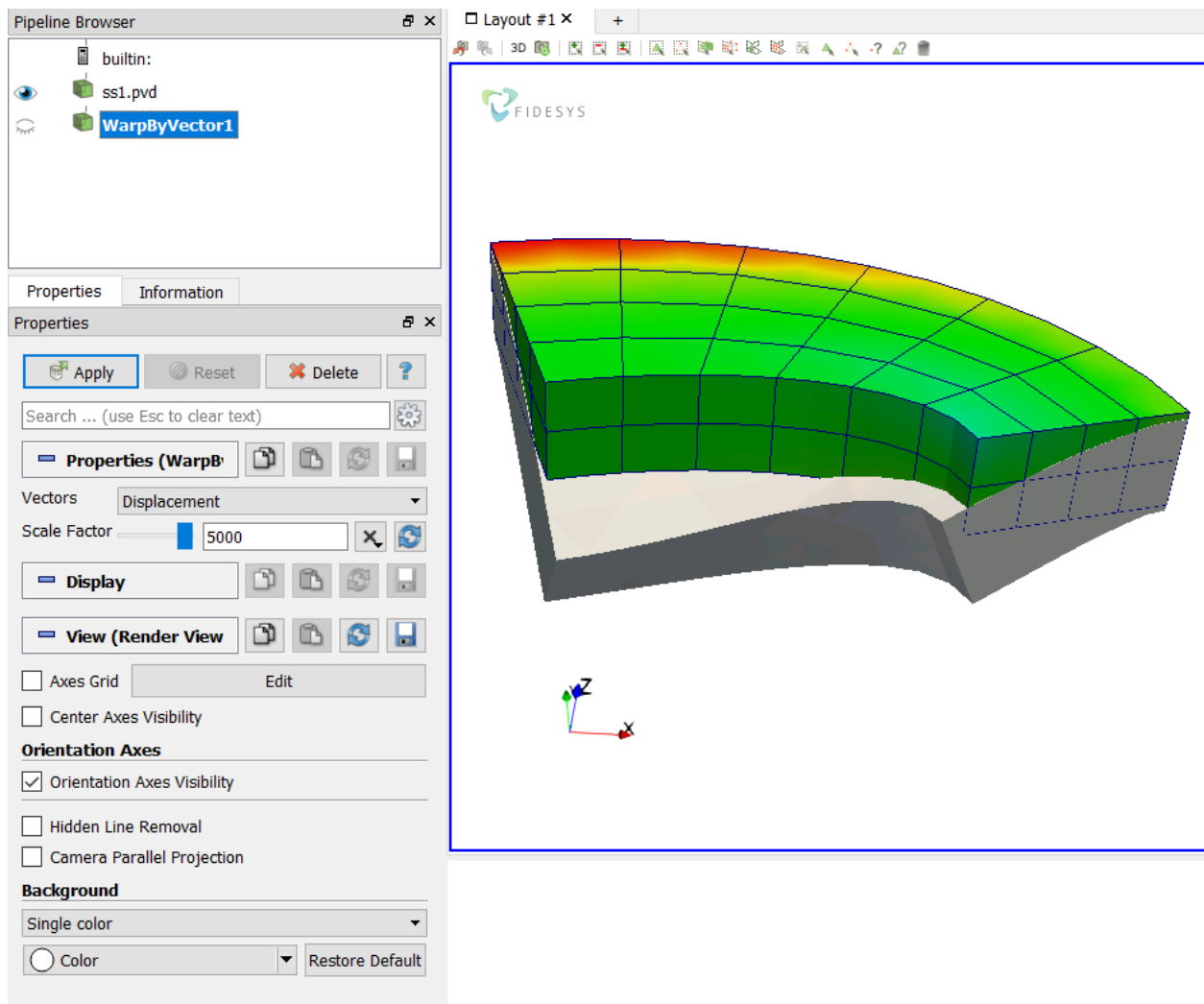

Using Console Interface

For geometry generation, meshing, setting boundary conditions and materials you can use Console Interface. The following program code allows performing the steps of the above-described guide you only need to manually specify the full path and name of the file to be saved.

```
reset
create Cylinder height 0.6 major radius 2 minor radius 1
create Cylinder height 0.6 major radius 3.25 minor radius 2.75
subtract volume 1 from volume 2
```



```
webcut volume 2 with plane xplane offset 0
webcut volume 2 with plane yplane offset 0
delete Body 2 3
webcut volume 4 with plane zplane offset 0 merge
curve 43 44 45 46 scheme equal
curve 43 44 45 46 interval 6
mesh curve 46 44 45 43
curve 12 14 39 41 scheme equal
curve 12 14 39 41 interval 4
mesh curve 12 14 39 41
curve 51 53 61 62 scheme equal
curve 51 53 61 62 interval 1
mesh curve 51 53 61 62
volume 4 5 scheme map
mesh volume 4 5
list Volume 4 mesh
create displacement on surface 33 40 dof 1 fix 0
create displacement on surface 35 39 dof 2 fix 0
create displacement on surface 36 38 dof 1 dof 2 fix 0
create displacement on curve 50 dof 3 fix 0
create pressure on surface 31 magnitude 1e6
create material 1
modify material 1 name 'Material 1'
modify material 1 set property 'MODULUS' value 2.1e+11
modify material 1 set property 'POISSON' value 0.3
block 1 add volume 4 5
block 1 material 1
block 1 element solid order 1
analysis type static elasticity dim3
calculation start path 'D:/Fidesys/example.pvd'
```



It is also possible to run the file *Example_1_Static_3D.jou* by selecting Journal Editor on Toolbar. In a pop-up window of the main menu select **File** → **Open** and open the necessary journal file.

Static load (gravity force)

R.J. Roark, *Formulas for Stress and Strain*, 4th Edition? McGraw-Hill Book Co., Inc., New York, NY, 1965, pg 112, no. 33

The problem of the tube bending of under gravity force is to be solved. The pictures below represent a geometric model of the problem:

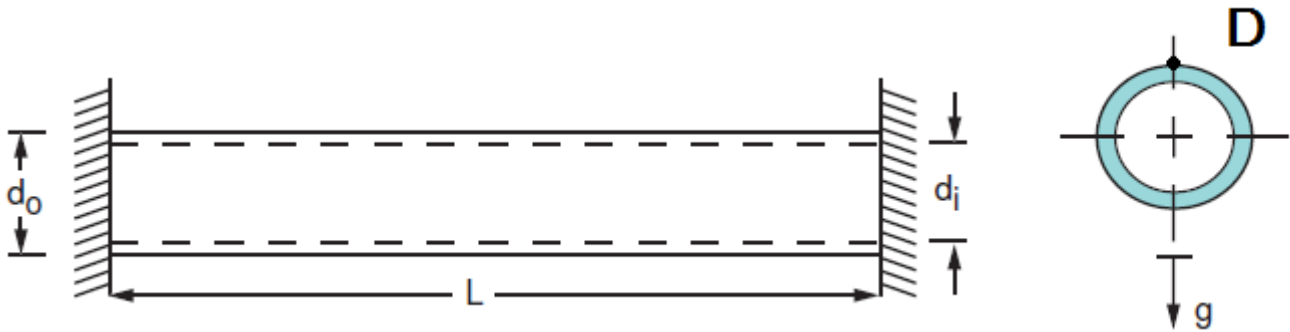

The side edges are rigidly fixed on all displacements and rotations. Material parameters are $E = 30e6$ psi, $\nu = 0.0$, $\rho = 0.00073$ lb-sec²/in⁴. The gravity force is defined via the acceleration $g = 386$ in/sec². The geometrical dimensions of the model: $L = 200$ in, $d_o = 2$ in, $d_i = 1$ in.

Due to the symmetry of the problem, half tube will now be considered ($L/2$).

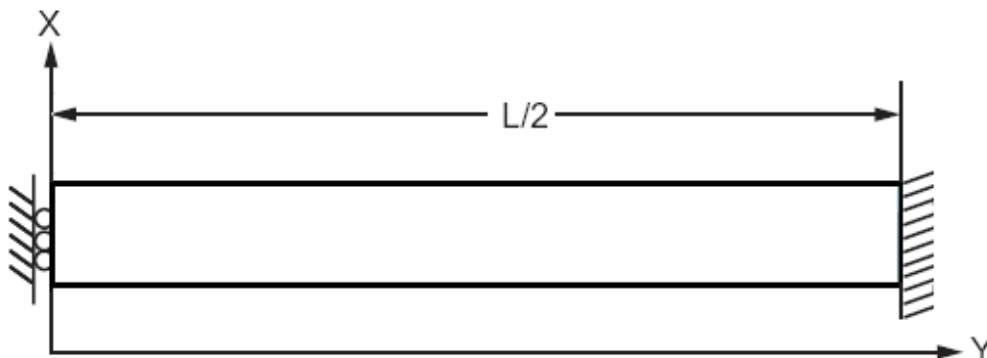

Test pass criterion is the following: displacement in the center of the tube u_{yy} at the point D (0, $d_o/2$, 0) is -0.12529 within 3%.

Geometry creation

1. Create the first circular cylinder.

Select volume geometry generation section on Command Panel (Mode — **Geometry**, Entity — **Volume**, Action — **Create**). Select **Cylinder** in the list of geometric elements. Specify the cylinder dimensions:

- Height: 100;
- Cross section: Circular;
- Radius: 1;

Click **Apply**.

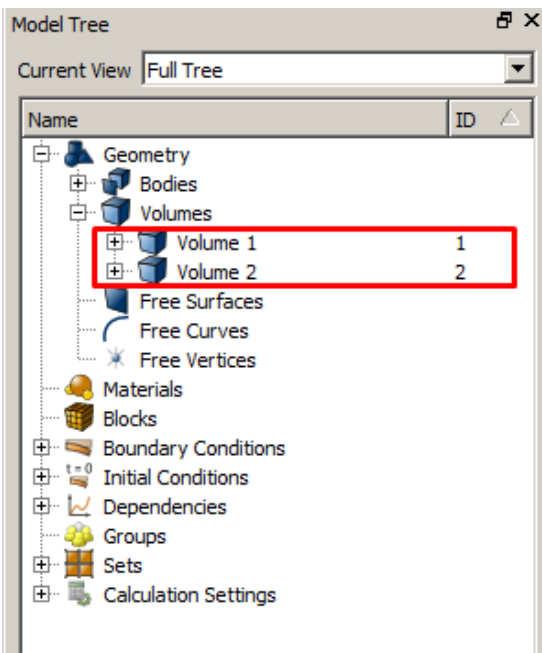
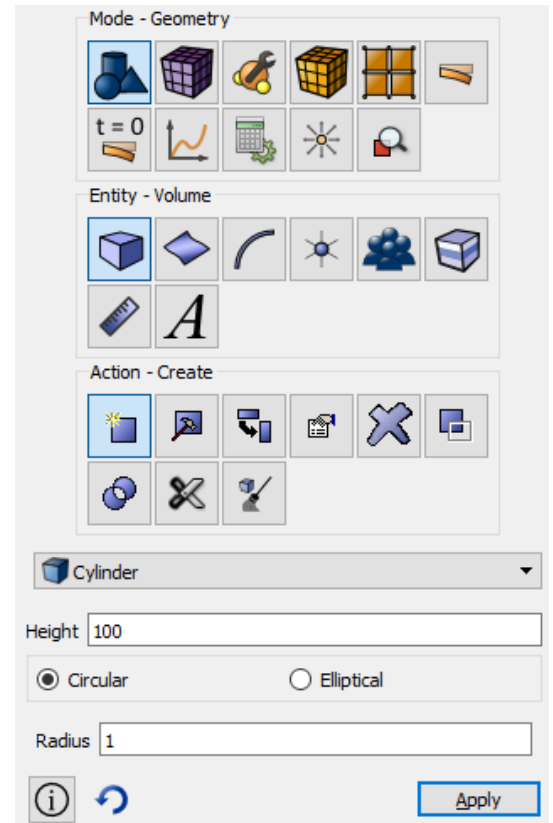

2. Create the second cylinder.

Select volume geometry generation section on Command Panel (Mode — **Geometry**, Entity — **Volume**, Action — **Create**). Select **Cylinder** in the list of geometric elements. Specify the cylinder dimensions:

- Height: 100;
- Cross section: Circular;
- Radius: 0.5;

Click **Apply**.

As a result, two generated entities are displayed in the Model Tree (Volume 1 and Volume 2).

3. Subtract the first cylinder from the second one.

Select volume geometry generation section on Command Panel (Mode — **Geometry**, Entity — **Volume**, Action — **Boolean**). Select **Subtract** in the list of operations. Set the following parameters:

- A Volume ID(s): 1 (the volumes to be subtracted);
- B Volume ID(s): 2 (volumes from which other volumes will be subtracted).

Click **Apply**.

As a result, only one volume is displayed in the Model Tree (Volume 1).

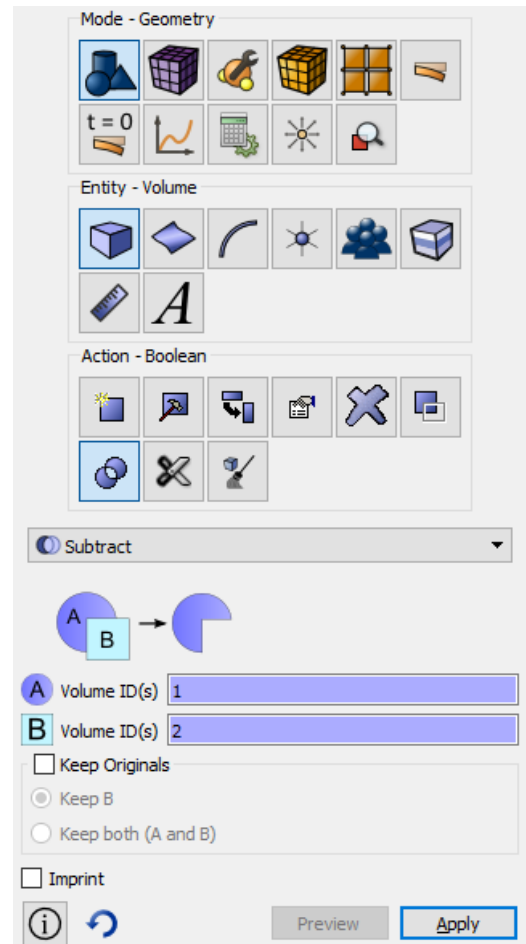
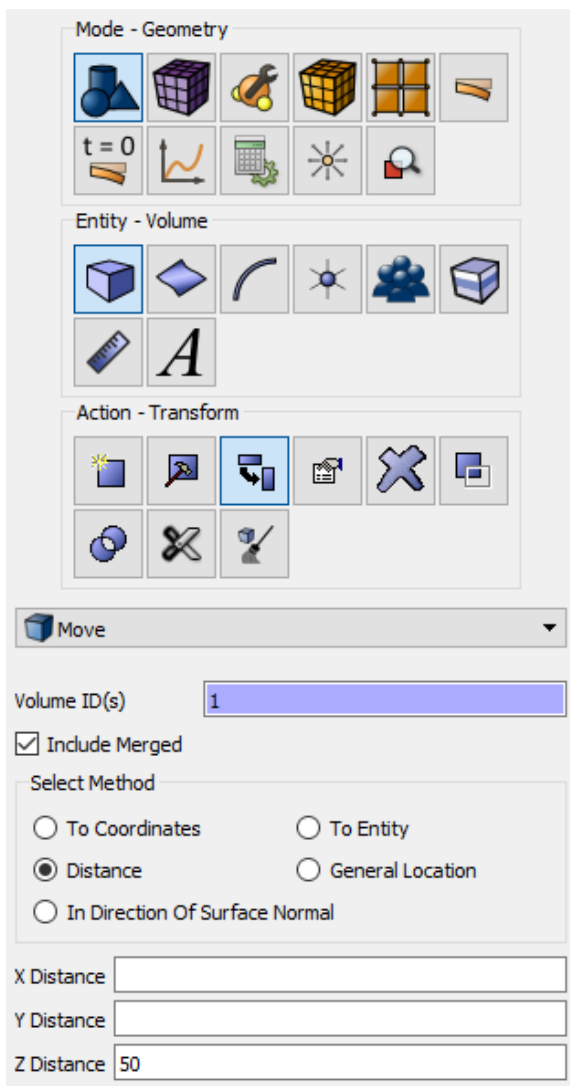

4. Place the volume to the coordinate origin.

Select volume geometry generation section on Command Panel (Mode — **Geometry**, Entity — **Volume**, Action — **Transform**). Select **Move** from the list of possible types of slices. Set the following parameters:

- Volumes ID(s): 1 (the volume to be cut);
- Checkbox Distance;
- Z Distance: 50;

Click **Apply**.

Thus, the center of the left end of the tube is placed in the origin of coordinates.

Meshing

1. Set the approximate size of the elements.

Select volume mesh generation section on Command Panel (Mode—**Mesh**, Entity—**Volume**, Action—**Intervals**). Specify the approximate size of the elements:

- Select volumes: 1;
- Select Approximate size from the drop-down list;
- Approximate size: 0.25;

Click **Apply Size**.

2. Select the way of mesh generation.

Select volume mesh generation section on Command Panel (Mode—**Mesh**, Entity—**Volume**, Action—**Mesh**).

- Select volumes: 1;
- Select meshing scheme: Polyhedron

Click **Apply Size**. Click **Mesh**.

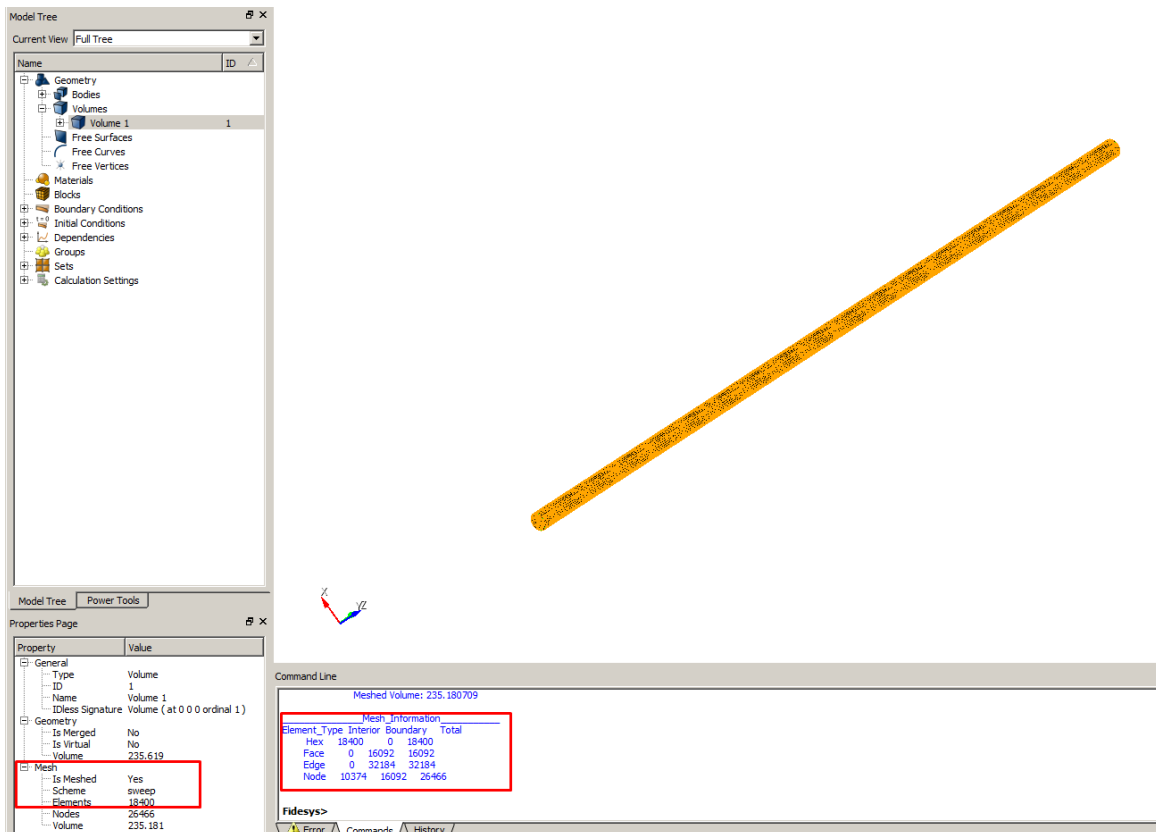
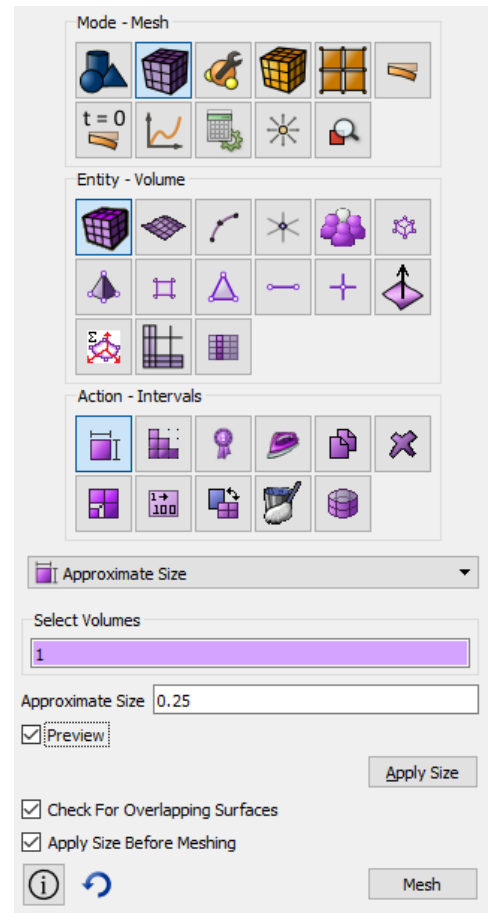

The resulting number of elements can be found on the property page by clicking on Volume 1 in the Model Tree on the left.

To view the mesh properties, you can follow these steps:

- Select the entire model
- Right-click on the model
- In the pop-up menu, select List Information – List Mesh Info
- Information on the mesh will be displayed in Command Line

Setting boundary conditions

1. Fix the right lateral edge at all directions.

Select Mode — **Boundary Conditions**, Entity — **Displacement**, Action — **Create** on Command Panel. Set the following parameters:

- System Assigned ID;
- Entity List: Surface;
- Entity ID(s): 8;
- Degrees of Freedom: All;
- DOF Value: 0.

Click **Apply**.

2. Fix the left lateral edge along X and Z axes by analogy.

Select Mode — **Boundary Conditions**, Entity — **Displacement**, Action — **Create** on Command Panel. Set the following parameters:

- System Assigned ID;
- Entity List: Surface;
- Entity ID(s): 9;
- Degrees of Freedom: X-Translation Disp, Z-Translation Disp;
- DOF Value: 0.

Click **Apply**.

Mode - Boundary Conditions

Entity - Displacement

Action - Create

ID/Name

New ID

Name

System Assigned ID

Entity List

Nodeset Volume Surface Curve

Hex Tet Face Vertex

Tri Edge Node

Entity ID(s) 8

Degrees Of Freedom

All

X-Translation Disp X-Rotation Disp

Y-Translation Disp Y-Rotation Disp

Z-Translation Disp Z-Rotation Disp

DOF Value 0

Specify Combination

Overwrite Average

Smallest Largest

3. Set the gravity force.

Select Mode — **Boundary Conditions**, Entity — **Gravity**, Action — **Create** on Command Panel. Set the following parameters:

- Global;
- Directions: Y;
- Value: -386.

Click **Apply**.

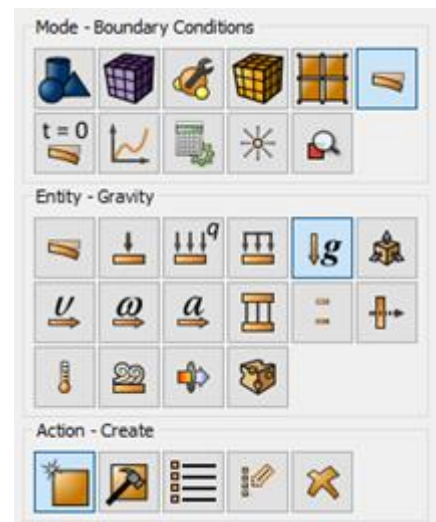

Setting material and element type

1. Create the material.

Select setting the material properties section on Command Panel (Mode — **Material**, Entity — **Materials management**).

In the Materials Management window that opens, in the second column, click on the caption Enter the name of the material and write "Material 1". Press the ENTER key.

In the left column, select Elasticity - Hooke Material. Select with the mouse the characteristic Young's modulus. Hold down the left mouse button and drag the label to Material Properties. Double-click in the Value field next to Young's modulus and enter the number $30e6$.

Similarly, from the Hooke Material section add the Poisson Ratio 0.3 ; from the section General - Density: 0.00073 .

Click **Apply**.

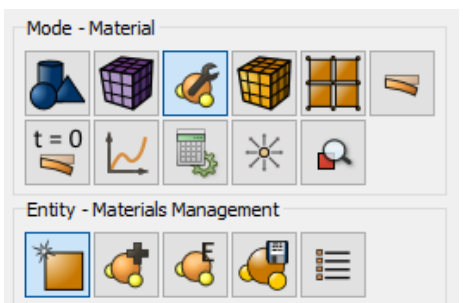

2. Create the block of one material type.

Select setting the material properties section on Command Panel (Mode — **Blocks**, Entity — **Block**, Action — **Add**). Set the following parameters:

- Block ID: 1;
- Entity list:: Volume;
- Entity ID(s): 1 (or by the command *all*).

Click **Apply**.

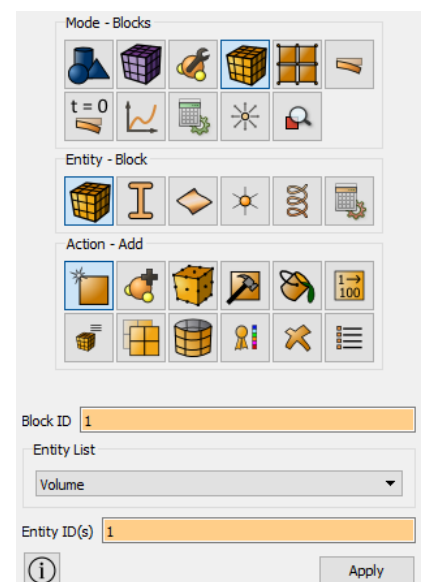

3. Assign the material to the block.

Select setting the material properties section on Command Panel (Mode — **Blocks**, Entity — **Block**, Action — **Set material**). Set the following parameters:

- Block ID(s): 1;
- Select the previously created material in the list: Material 1.

Click **Apply**.

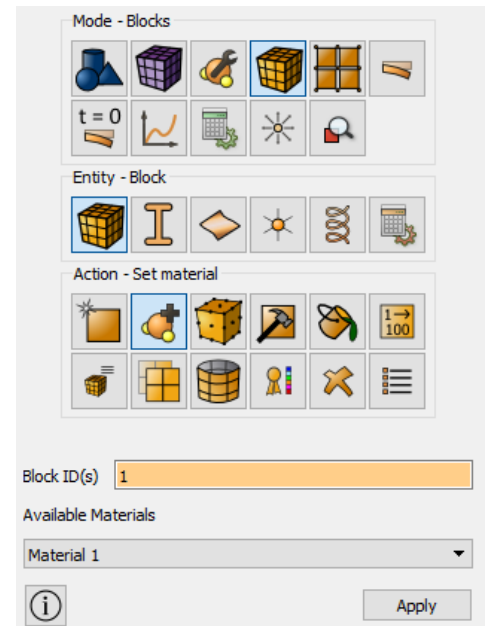

4. Assign the element type to the block.

Select setting the material properties section on Command Panel (Mode — **Blocks**, Entity — **Block**, Action — **Element Types**). Set the following parameters:

- Block ID(s): 1;
- Category: Solid;
- Order: 1

Click **Apply**.

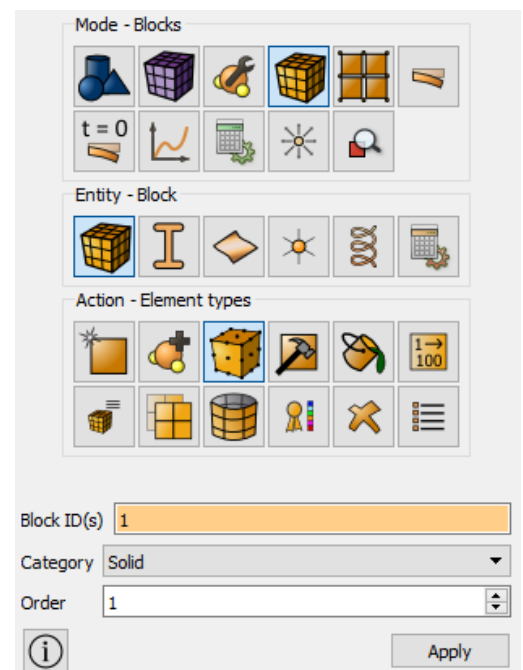

Starting calculation

1. Set the type of the problem to be solved.

Select calculation setting section on Command Panel (Mode — **Calculation settings**, Calculation settings — **Static**, Static — **General**). Select:

- Dimension: 3D;
- Model: Elasticity.

Click **Apply**.

In a pop-up window select a folder to save the result and enter the file name.

If the calculation is finished successfully, you will see a message in the Console: "*Calculation finished successfully at <date> <time>*".

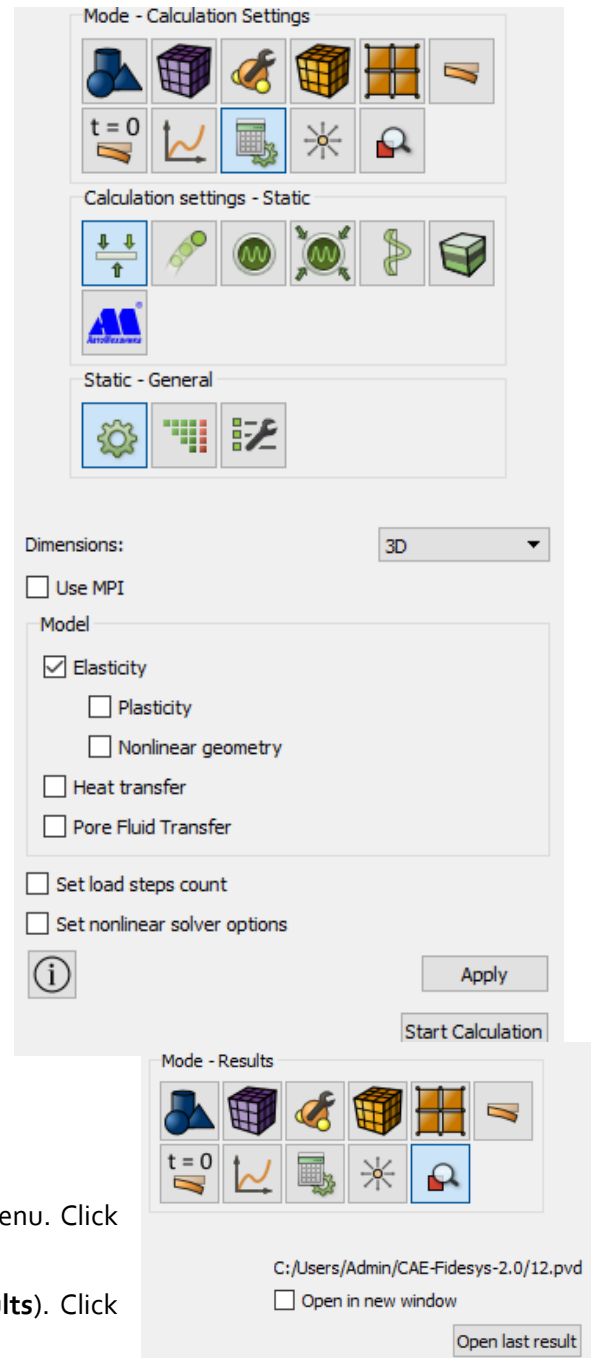

Results analysis

1. Open the file with the results. You can do this in one of the three ways.

- Click Ctrl+E.
- Select **Calculation** → **Open Results** in the Main Menu. Click **Open last result**.
- Select **Results** on Command Panel (Mode — **Results**). Click **Open Results**.



To apply all of the filters changes automatically in **Fidesys Viewer**, click **Apply changes to parameters automatically** on Command Panel.

2. Display the U_{yy} component of the displacement field on the model.

In **Fidesys Viewer** window set the following parameters on Toolbar:

- Representation Mode: Surface;
- Representation Field: Displacement;
- Representation Component: Y.
- Surface.



After applying the settings, you will see the following picture:

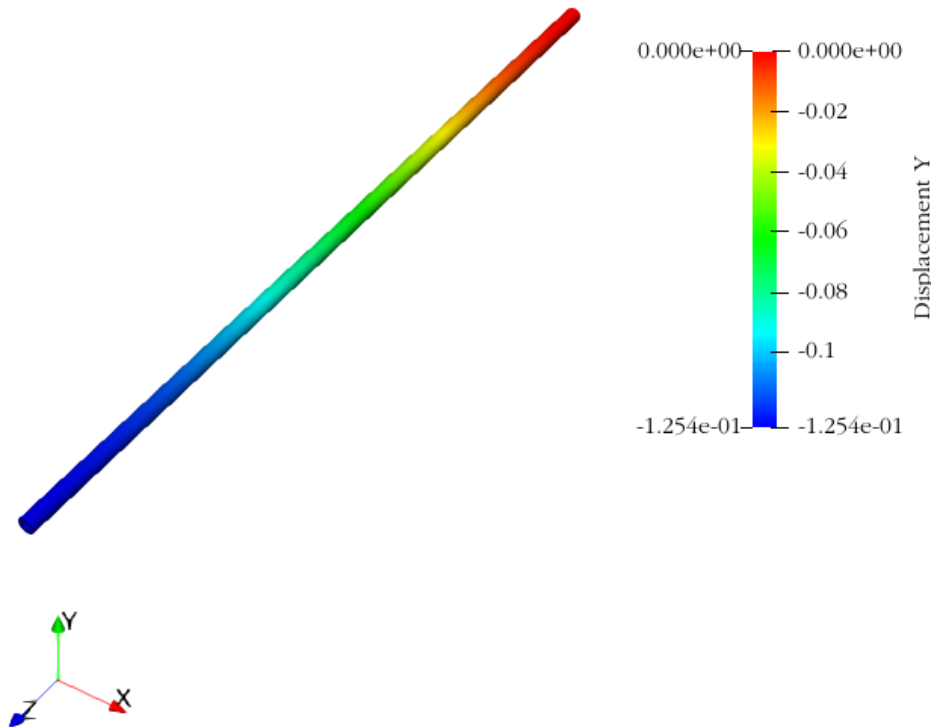

3. Check the maximum value U_{yy} at the selected point D.

In the picture, it is the maximum in modulus Displacement (blue). It corresponds to -0.127222 in the color legend. The difference between the resulting value -0.1254 and the required -0.12524 is 0.13%.

4. Download numerical data.

Select **File** → **Save Data** in the Main Menu or click **Ctrl+S**. Enter the file name (*.csv format), leave it by default. Click **OK**. The saved file is an ordinary table of numerical data which can be opened in any text editor.

5. You can see the way the body is deformed under the applied pressure.

To do this, select **Filters** → **Alphabetical** → **Warp By Vector**. Set the following parameters in the tab **Properties**:

- Vectors: Displacement;
 - Scale Factor: 100.

As a result, the deformed body is displayed at the picture. To see the original model, click the button  near the model in the Model Tree. The picture below shows the deformed (solid grey filling) and the original model (with the field of displacements distribution along Y axis).

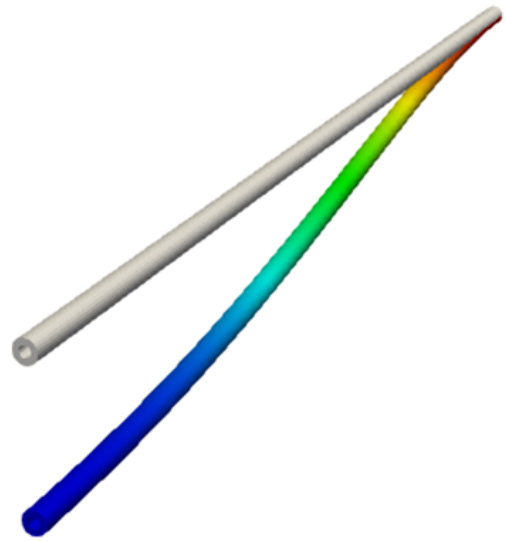
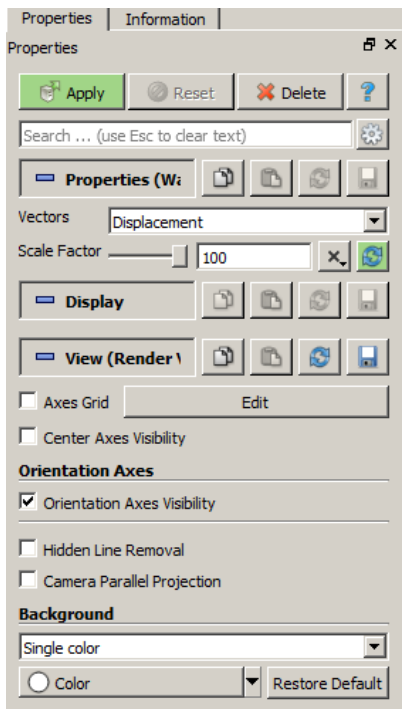

Using Console Interface

For geometry generation, meshing, setting boundary conditions and materials you can use Console Interface. The following program code allows performing the steps of the above-described guide, you only need to **manually specify the full path and name of the file to be saved**.

```

reset
create Cylinder height 100 radius 1
create Cylinder height 100 radius 0.5
subtract volume 2 from volume 1
volume 1 size 0.25
volume 1 scheme sweep
mesh volume 1
list volume 1 mesh
create displacement on surface 8 dof all fix 0
create displacement on surface 9 dof 1 dof 3 fix 0
create gravity global
modify gravity 1 dof 2 value -386
create material 1
modify material 1 name 'Material1'
modify material 1 set property 'POISSON' value 0
modify material 1 set property 'MODULUS' value 3e+7
modify material 1 set property 'DENSITY' value 0.00073
block 1 add volume 1
block 1 material 1
block 1 element solid order 2
analysis type static elasticity dim3
calculation start path "D:/Fidesys/calc/example.pvd
    
```



It is also possible to run the file *Example_2_Static_3D.jou* by selecting Journal Editor on Toolbar. In a pop-up window of the main menu select **File** → **Open** and open the necessary journal file.

Static load (beam model, reaction forces)

S.H. Crandall, N.C. Dahl, *An Introduction to the Mechanics of Solids*, McGraw-Hill Book Co., Inc., New York, NY, 1959, pg. 389, ex. 8.9

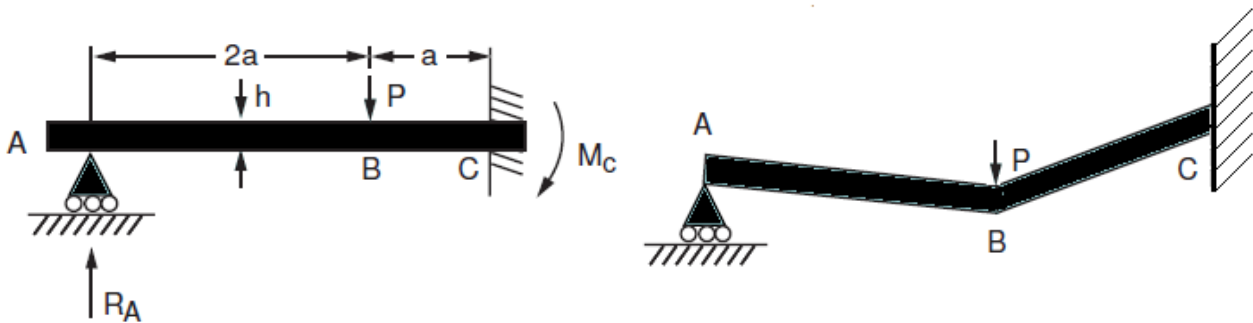

The problem of static load of a square section beam is being solved. The picture represents a geometric model of the problem: $a = 50 \text{ in}$, beam section $1 \times 1 \text{ in}$. The boundary conditions are presented in the picture; the force applied at the point B is $F_y = -1000 \text{ lb}$. The material parameters are $E = 30e6 \text{ psi}$, $\nu = 0.3$.

Test pass criterion is the following: reaction force R_A at the point A (0,0,0) is 148.15 lb, reaction moment at the point C is 27778 in-lb within 1.5%.

Geometry creation

1. Create a straight line 100 in length (segment AB).

Select volume geometry generation section on Command Panel (Mode — **Geometry**, Entity — **Curve**, Action — **Create**). Select **Line** in the list of geometric elements. Create it using **Location and Direction**. Set the following parameters:

- Location: 0 0 0 (*line origin*);
- Direction: 1 0 0 (*along X axis*);
- Length: 100;

Click **Apply**.

2. Create a straight line 50 in length (segment BC).

Select volume geometry generation section on Command Panel (Mode — **Geometry**, Entity — **Curve**, Action — **Create**). Select **Line** in the list of geometric elements. Create it using **Location and Direction**. Set the following parameters:

- Location: 100 0 0 (*line origin*);
- Direction: 1 0 0 (*along X axis*);
- Length: 50;

Click **Apply**.

As a result, in left side of the Model Tree there are two free curves having no common vertices.

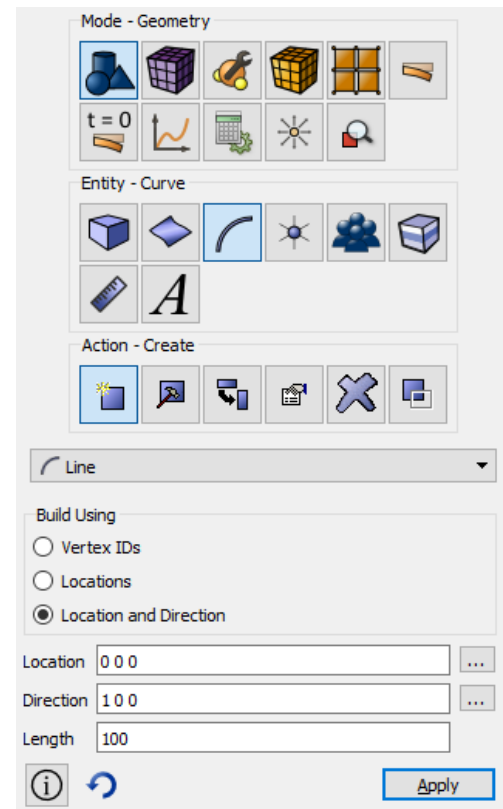

3. Unite two vertices.

Select volume geometry generation section on Command Panel (Mode — **Geometry**, Entity — **Vertex**, Action — **Merge**). Set the following parameters:

- Vertex ID: 2 3 (*using space after each of them*);

Click **Apply**.

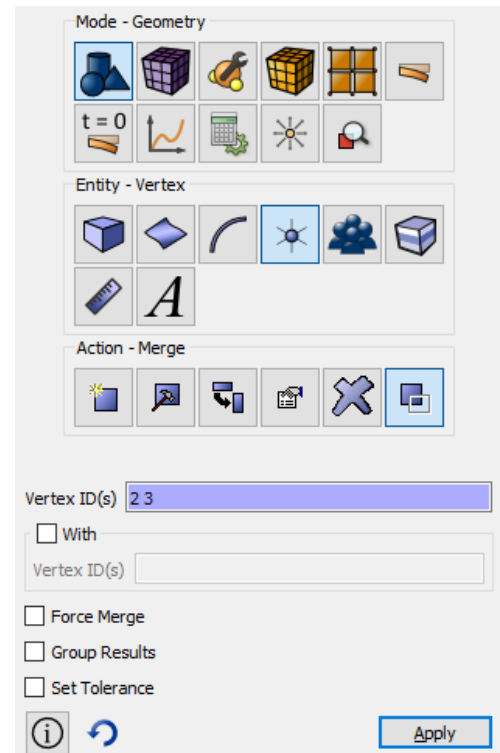

Meshing

1. Select meshing on curves section on Command Panel (Mode — **Mesh**, Entity — **Curve**, Action — **Mesh**). Specify the parameters of mesh refinement:

- Select Curves: all;
- Select the way of meshing: Equal;
- Select the meshing parameters: Interval;
- Interval: 1.

Click **Apply Size**.

Click **Mesh**.

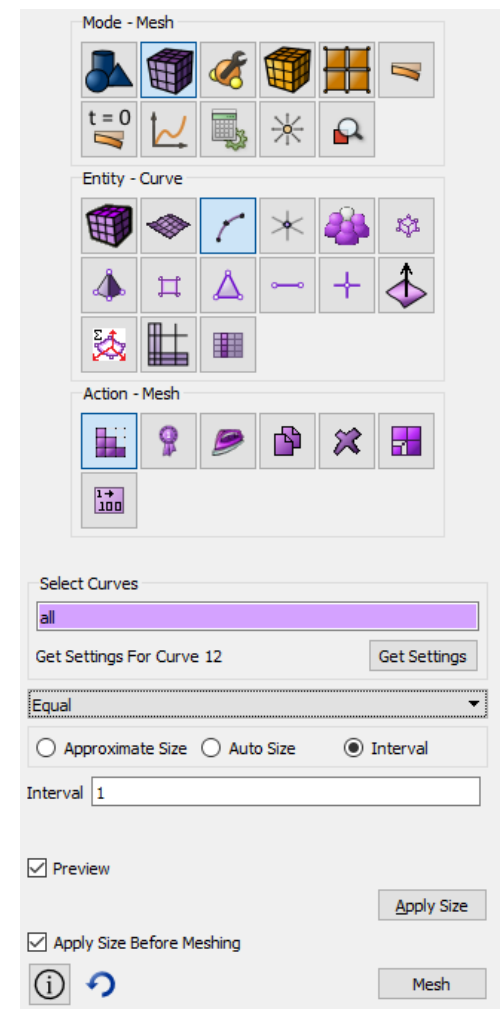

Setting boundary conditions

1. Fix the point C at all directions.

Select Mode — **Boundary Conditions**, Entity — **Displacement**, Action — **Create** on Command Panel. Set the following parameters:

- System Assigned ID;
- Entity List: Vertex;
- Entity ID(s): 4;
- Degrees of Freedom: All;
- DOF Value: 0.

Click **Apply**.

Mode - Boundary Conditions

Entity - Displacement

Action - Create

ID/Name

New ID

Name

System Assigned ID

Entity List

Nodeset Volume Surface Curve

Hex Tet Face Vertex

Tri Edge Node

Entity ID(s) 4

Degrees Of Freedom

All

X-Translation Disp X-Rotation Disp

Y-Translation Disp Y-Rotation Disp

Z-Translation Disp Z-Rotation Disp

DOF Value 0

Specify Combination

Overwrite Average

Smallest Largest

2. Fix the point A at the Y and Z displacement.

Select Mode — **Boundary Conditions**, Entity — **Displacement**, Action — **Create** on Command Panel. Set the following parameters:

- System Assigned ID;
- Entity List: Vertex;
- Entity ID(s): 1;
- Degrees of Freedom: Y-Translation Disp, Z-Translation Disp;
- DOF Value: 0.

Click **Apply**.

3. Apply force at the point B.

Select Mode — **Boundary Conditions**, Entity — **Force**, Action — **Create** on Command Panel. Set the following parameters:

- System Assigned ID;
- Entity List: Vertex;
- Entity ID(s): 2;
- Force: 1000;
- Click Direction 0 -1 0.

Click **Apply**.

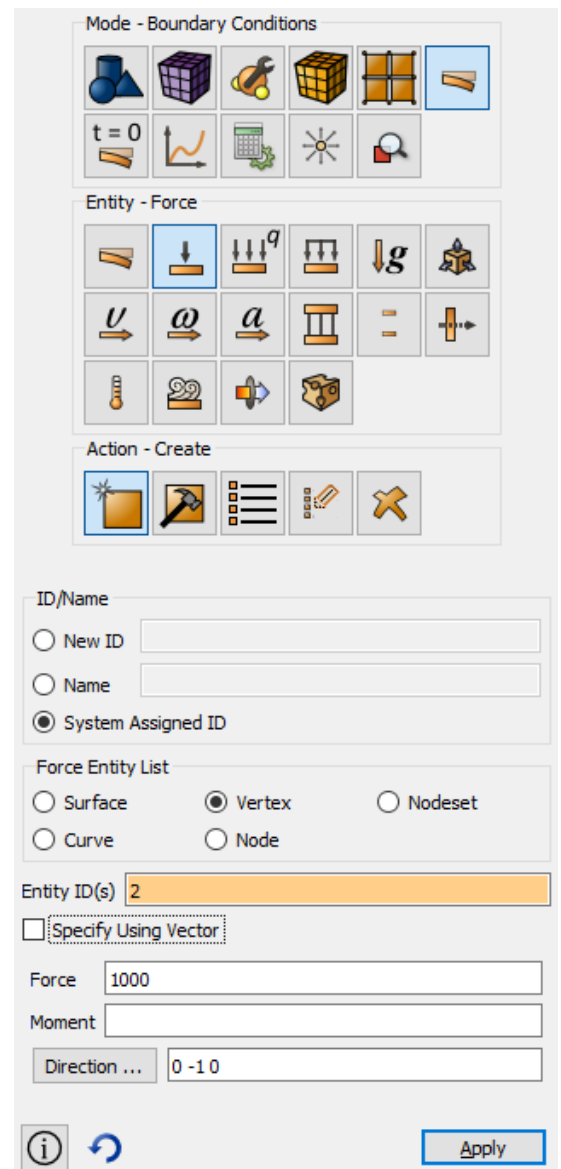

Setting material and element type

1. Create the material.

Select setting the material properties section on Command Panel (Mode — **Material**, Entity — **Materials Management**).

In the Materials Management window that opens, in the second column, click on the caption Enter the name of the material and write "Material 1". Press the ENTER key.

In the left column, select Elasticity - Hooke Material. Select with the mouse the characteristic Young's modulus. Hold down the left mouse button and drag the label to Material Properties. Double-click in the Value field next to Young's modulus and enter the number 30e6. Similarly, from the Hooke Material section add the Poisson Ratio 0.3;

Click **Apply**.

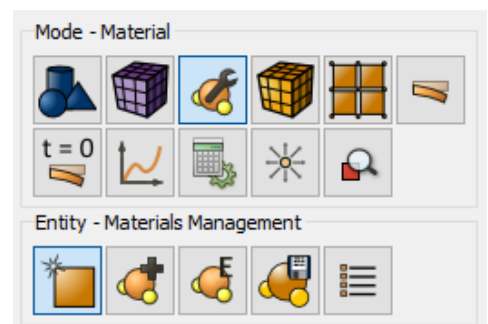

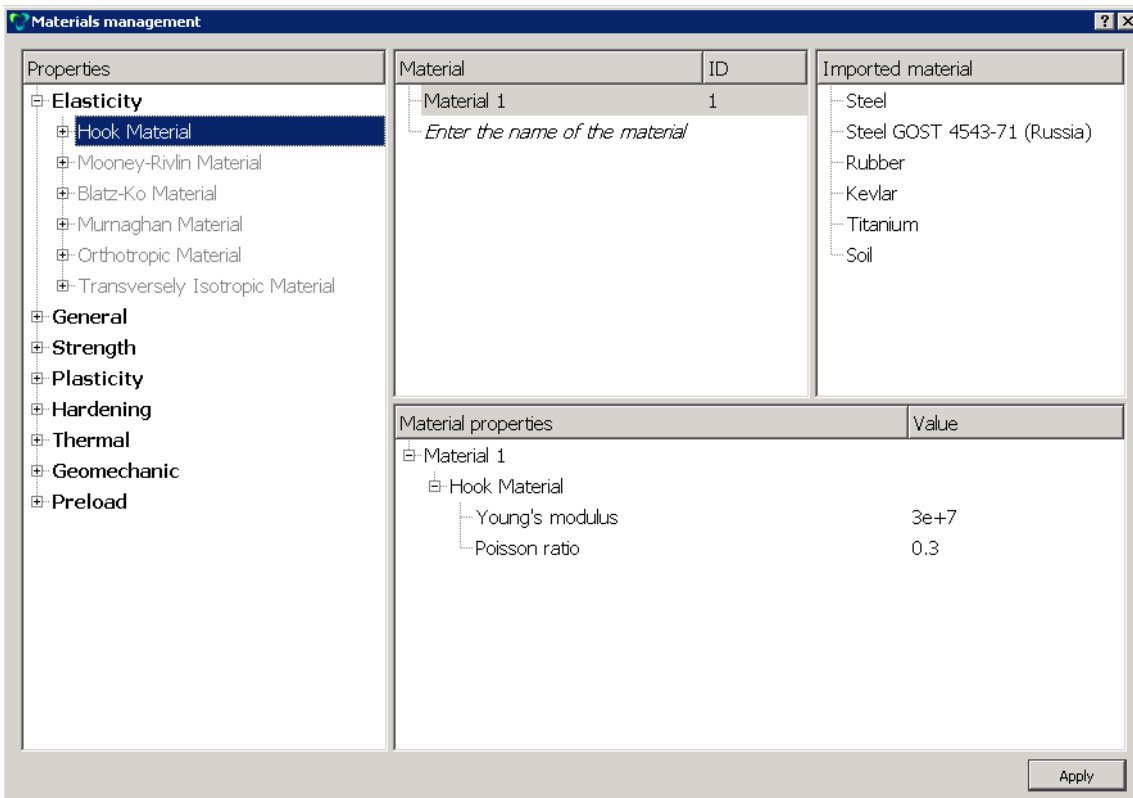

2. Create the block of one type of the material.

Select setting the material properties section on Command Panel (Mode — **Blocks**, Entity — **Block**, Action — **Add**). Set the following parameters:

- Block ID: 1;
- Entity list: Curve;
- Entity ID(s): 1 2 (or by the command *all*).

Click **Apply**.

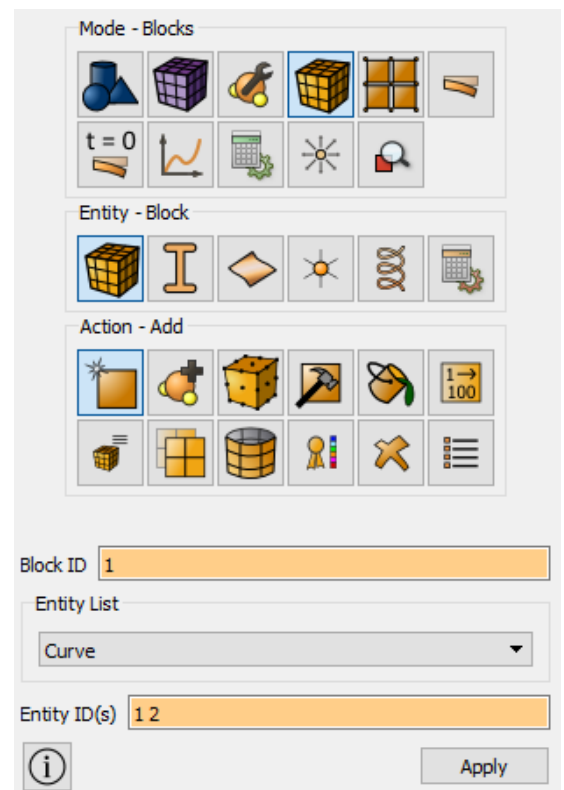

3. Assign the material to the block.

Select setting the material properties section on Command Panel (Mode — **Blocks**, Entity — **Block**, Action — **Set material**). Set the following parameters:

- Block ID(s): 1;
- Select the previously created material in the list: Material 1.

Click **Apply**.



4. Assign the element type.

Select setting the material properties section on Command Panel (Mode — **Blocks**, Entity — **Block**, Action — **Element types**). Set the following parameters:

- Block ID(s): 1;
- Category: Beam;
- Order: 1.

Click **Apply**.



Setting beam cross section profile

1. Set beam parameters.

Select setting the material properties section on Command Panel (Mode — **Blocks**, Entity — **Beam Properties**). Set the checkbox **Select profile**. Select **Rectangle** in the list of geometric elements. Specify the following parameters:

- Block ID: 1;
- Height (H): 1;
- Width (B): 1;

Click **Apply**.

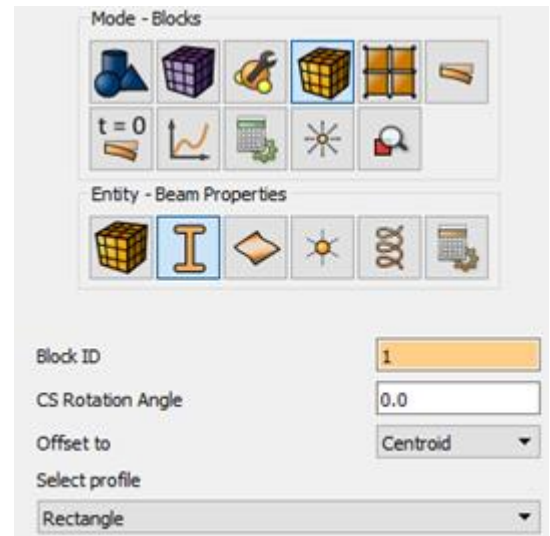

Starting calculation

1. Set the type of the problem to be solved.

Select calculation setting section on Command Panel (Mode — **Calculation settings**, Calculation settings — **Static**, Static — **General**). Select:

- Dimension: 3D;
- Model: Elasticity.

Click **Apply**.

2. Set the solver settings.

Select calculation setting section on Command Panel (Mode — **Calculation settings**, Calculation settings — **Static**, Static — **Solver**). Select the solver method (direct or iterative) and set Convergence Parameters in case of choosing an iterative one. You can also leave all the settings by default.

Click **Apply**.

3. Set the reaction force calculation

Go to the tab **Static – Output fields** and set the checkbox **Calculate nodal and reaction forces**.

Click **Apply**.

Click **Start Calculation**.

Note: Without setting the checkbox **Calculate nodal and reaction forces**, the field is not calculated.

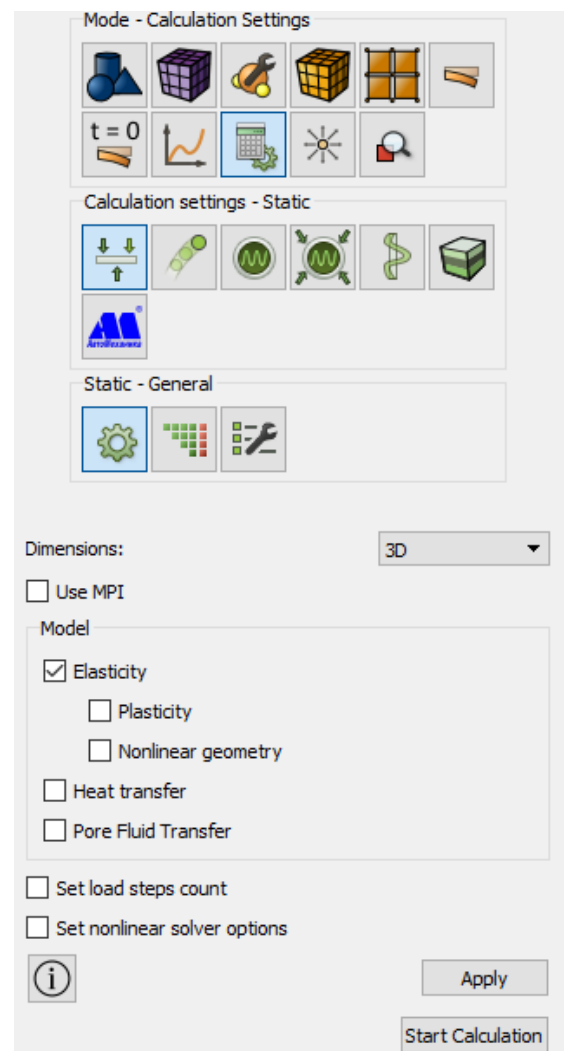

4. In a pop-up window select a folder to save the result and enter the file name.

- If the calculation is finished successfully, you will see a message in the Console: "*Calculation finished successfully at <date> <time>*".

Results analysis

- Open the file with the results. You can do this in one of the three ways.

- Click Ctrl+E.
- Select **Calculation** → **Open Results** in the Main Menu. Click **Open last result**.
- Select **Results** on Command Panel (Mode — **Results**). Click **Open Results**.

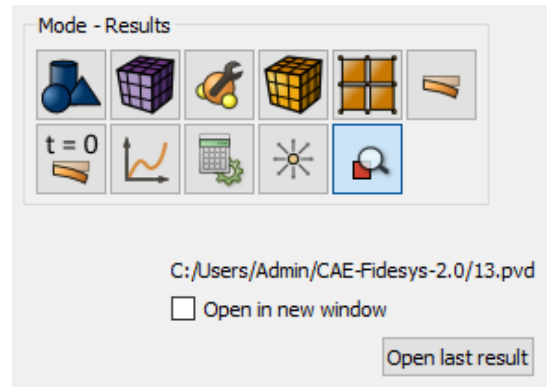

- Display the u_y component of the displacements field.

In **Fidesys Viewer** window set the following parameters on Toolbar:

- Representation Mode: Surface;
- Representation Field: Displacement;
- Representation Component: Y.

The field of displacements distribution along the Y axis will be displayed on the model



- Check the numerical value of the reaction force at the point A.

Display Component 2 of the Reaction Forces field.



On the **Fidesys Viewer** Main Panel, click Select Points On surface.



Select the limiting left point (point A) on the geometric model.

To quickly view the information at the fixed point, click **pointsInfo** on the Main Panel.



In the pop-up window, components of the reaction force at the selected point will be displayed.

Points information				
Node ID	X	Y	Z	Reaction Force
1	0	0	0	0 150.977 0

The difference between the resulting value 150.977 and the required 148.15 is less than 1,8%.

Please, do not close the window Points information.

- Check the numerical value of reaction moments at the point C.

Display Component Z of the Reaction_moment field.



On the **Fidesys Viewer** Main Panel, click Select Points On surface.



Select the limiting right point C on the geometric model.

In the window Points information components of the reaction moment at the selected point will be displayed.

Points information				
Node ID	X	Y	Z	Reaction Moment
3	150	0	0	0 0 -27353.5

The difference between the resulting value -27353.5 and the required -27377.3 is less than 0.01%.

5. Open 3D-image of the beam.

To display 3D-view of the beam cross section, set the focus on the calculation title and click the button  in the **Fidesys Viewer** standard line.



To apply all of the filters changes automatically, click **Apply changes to parameters automatically** on Command Panel.

6. Download numerical data.

Select **File** → **Save Data** in the Main Menu or click **Ctrl+S**. Enter the file name (*.csv format), leave it by default. Click **OK**. The saved file is an ordinary table of numerical data which can be opened in any text editor.

Using Console Interface

For geometry generation, meshing, setting boundary conditions and materials you can use Console Interface. The following program code allows performing the steps of the above-described guide, you only need to **manually specify the full path and name of the file to be saved**.

```

reset
create curve location 0 0 0 direction 1 0 0 length 100
create curve location 100 0 0 direction 1 0 0 length 50
merge vertex 2 3
curve all scheme equal
curve all interval 1
mesh curve all
create displacement on vertex 4 dof all fix
create displacement on vertex 1 dof 2 dof 3 fix
create force on vertex 2 force value 1000 direction 0 -1 0
create material 1
modify material 1 name 'Material1'
modify material 1 set property 'MODULUS' value 3e+7
modify material 1 set property 'POISSON' value 0
block 1 add curve 1 2
block 1 material 1
block 1 element beam
block 1 attribute count 7
block 1 attribute index 1 value 1 name 'Rectangle'
block 1 attribute index 2 value 0.0 name 'ey'
    
```

```
block 1 attribute index 3 value 0.0 name 'ez'  
block 1 attribute index 4 value 0.0 name 'angle'  
block 1 attribute index 5 value 0 name 'section_id'  
block 1 attribute index 6 value 1 name 'geom_H'  
block 1 attribute index 7 value 1 name 'geom_B'  
analysis type static elasticity dim3  
solver method auto use_uzawa auto try_other on  
output nodalforce on energy off midresults on record3d on log on vtu on material off  
calculation start path 'D:/Fidesys/example3.pvd'
```



It is also possible to run the file *Example_3_Static_Beam.jou* by selecting Journal Editor on Toolbar. In a pop-up window of the main menu select **File** → **Open** and open the necessary journal file.

Static load (shell)

Timoshenko S.P. Voynovskiy-Kriger S. Plates and shells, Nauka, Moscow, 1966, 636 pages [in Russian]

The problem of static load of square shell which two sides are clamped and the other two are freely supported, is being solved.. The picture represents a geometric model of the problem: $a = 1$ m, shell thickness is 0.1 m. The boundary conditions are presented in the picture. The plate is loaded by uniform pressure of 10 kPa.

Test pass criterion is the following: the maximum deflection is $1.19e-6$, moments $M_x=252$ N·m and $M_y=332$ N·m.

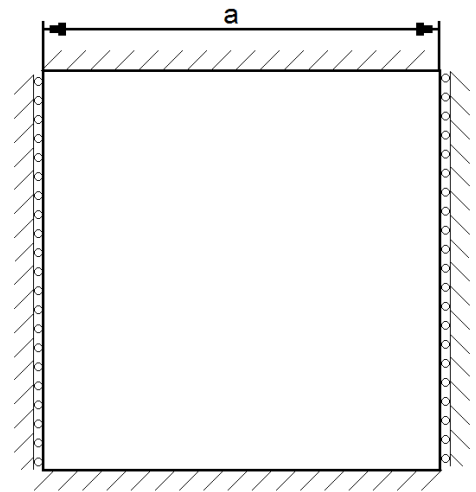

Geometry creation

1. Create the square 1 m on side.

Select volume geometry generation section on Command Panel (Mode — **Geometry**, Entity — **Surface**, Action — **Create**). Select **Rectangle** in the list of geometric elements. Set the parameters:

- Width: 1;
- Height: Optional.

Click **Apply**.

Meshing

1. Select surface mesh generation section on Command Panel (Mode — **Mesh**, Entity — **Surface**, Action — **Mesh**). Specify the following parameters:

- Select surfaces: 1;
- Select meshing scheme: Polyhedron;

Click **Apply Scheme**.

Click **Mesh**.

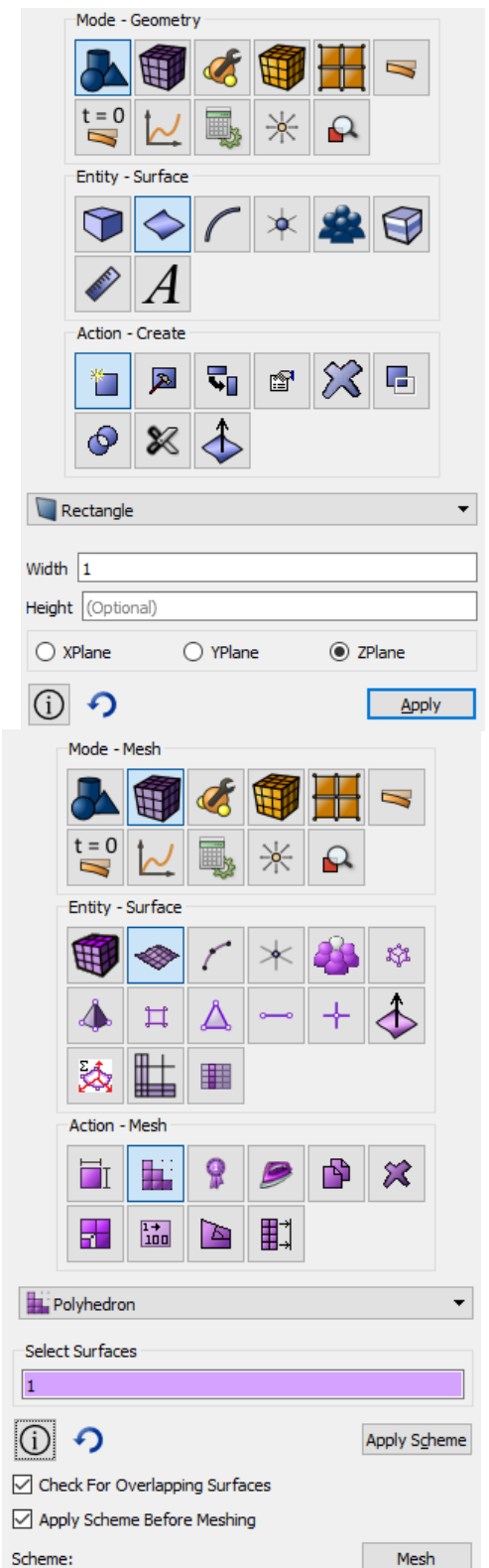
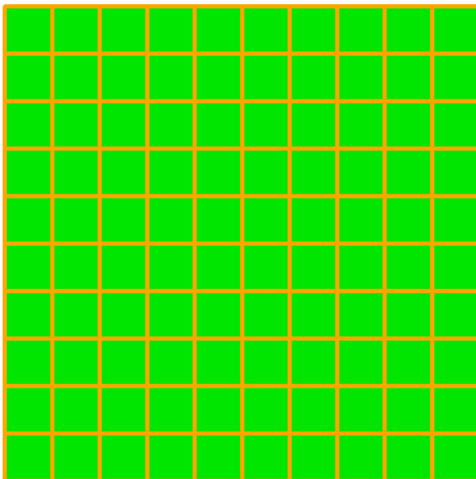

Setting boundary conditions

1. Fix the two edges rigidly.

Select Mode — **Boundary Conditions**, Entity — **Displacement**, Action — **Create** on Command Panel. Set the following parameters:

- System Assigned ID;
- Entity List: Curve;
- Entity ID(s): 1 3 (or sequentially click on the top and bottom edges);
- Degrees of Freedom: All;
- DOF Value: 0.

Click **Apply**.

2. Fix the two other edges at displacements.

Select Mode — **Boundary Conditions**, Entity — **Displacement**, Action — **Create** on Command Panel. Set the following parameters:

- System Assigned ID;
- Entity List: Curve;
- Entity ID(s): 2 4 (or sequentially click on the right and left edges);
- Degrees of Freedom: X-Translation Disp, Y-Translation Disp, Z-Translation Disp;
- DOF Value: 0.

Click **Apply**.

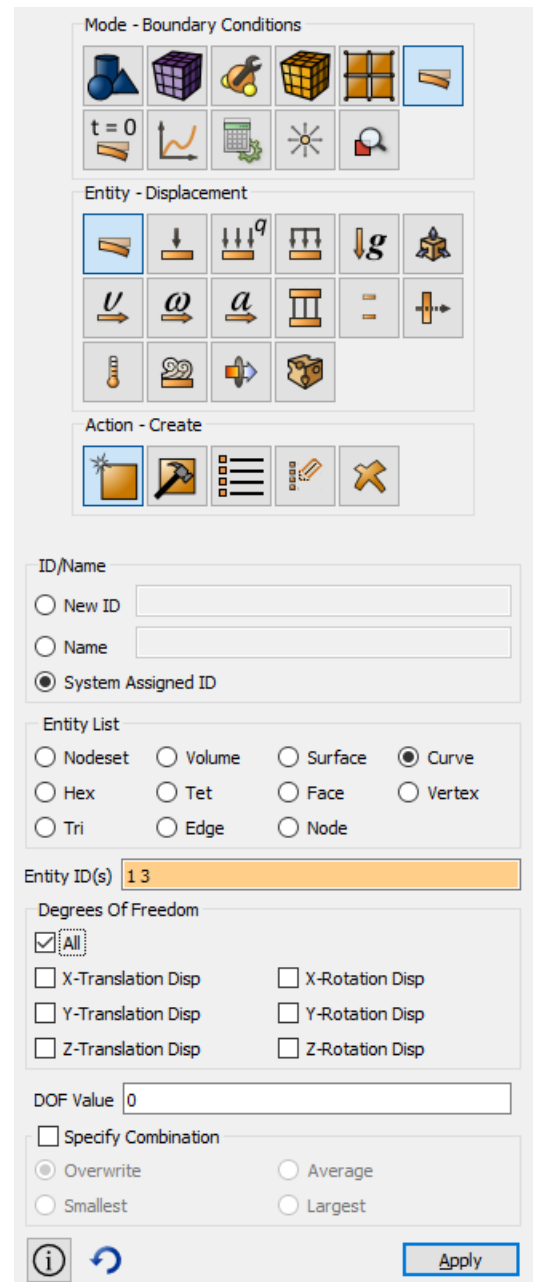

Apply the uniform pressure on the surface.

Select Mode — **Boundary Conditions**, Entity — **Pressure**, Action — **Create** on Command Panel. Set the following parameters:

- System Assigned ID;
- Entity List: Surface;
- Entity ID(s): 1;
- Magnitude Value: $1e4$;

Click **Apply**.

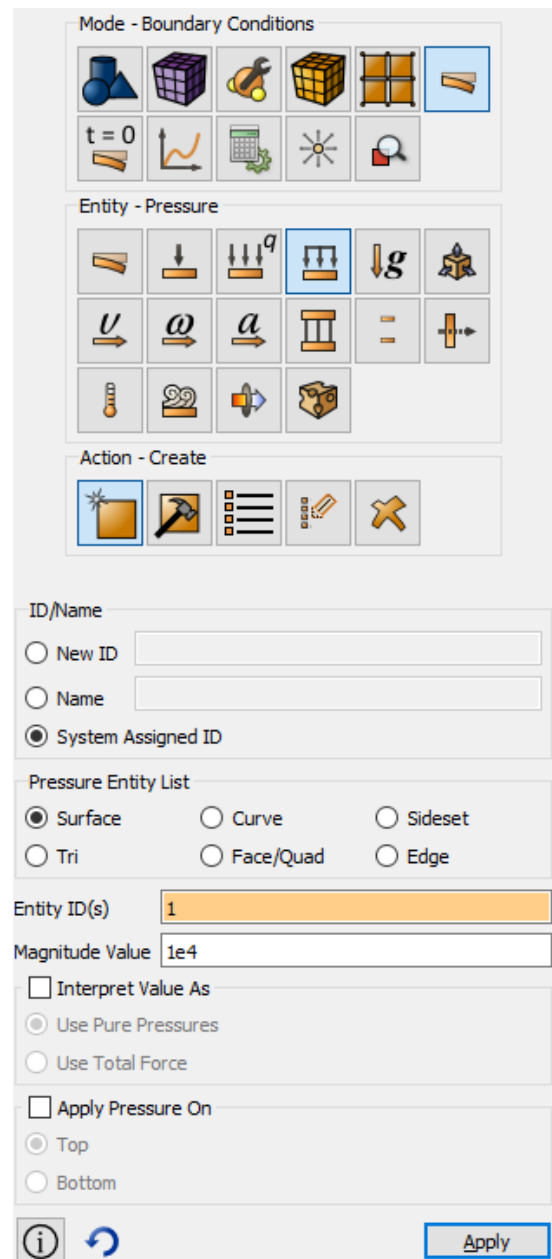

Setting material and element type

1. Create the material.

Select setting the material properties section on Command Panel (Mode — **Material**, Entity — **Materials management**).

In the Materials Management window that opens, in the second column, click on the caption Enter the name of the material and write "Material 1". Press the ENTER key.

In the left column, select Elasticity - Hooke Material. Select with the mouse the characteristic Young's modulus. Hold down the left mouse button and drag the label to Material Properties. Double-click in the Value field next to Young's modulus and enter the number $2e11$. Similarly, from the Hooke Material section add the Poisson Ratio 0.3;

Click **Apply**.

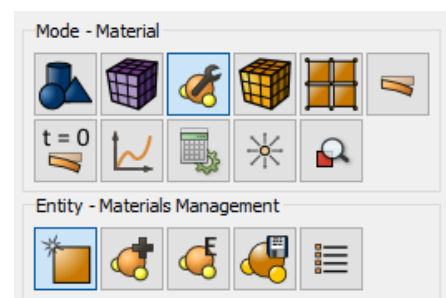

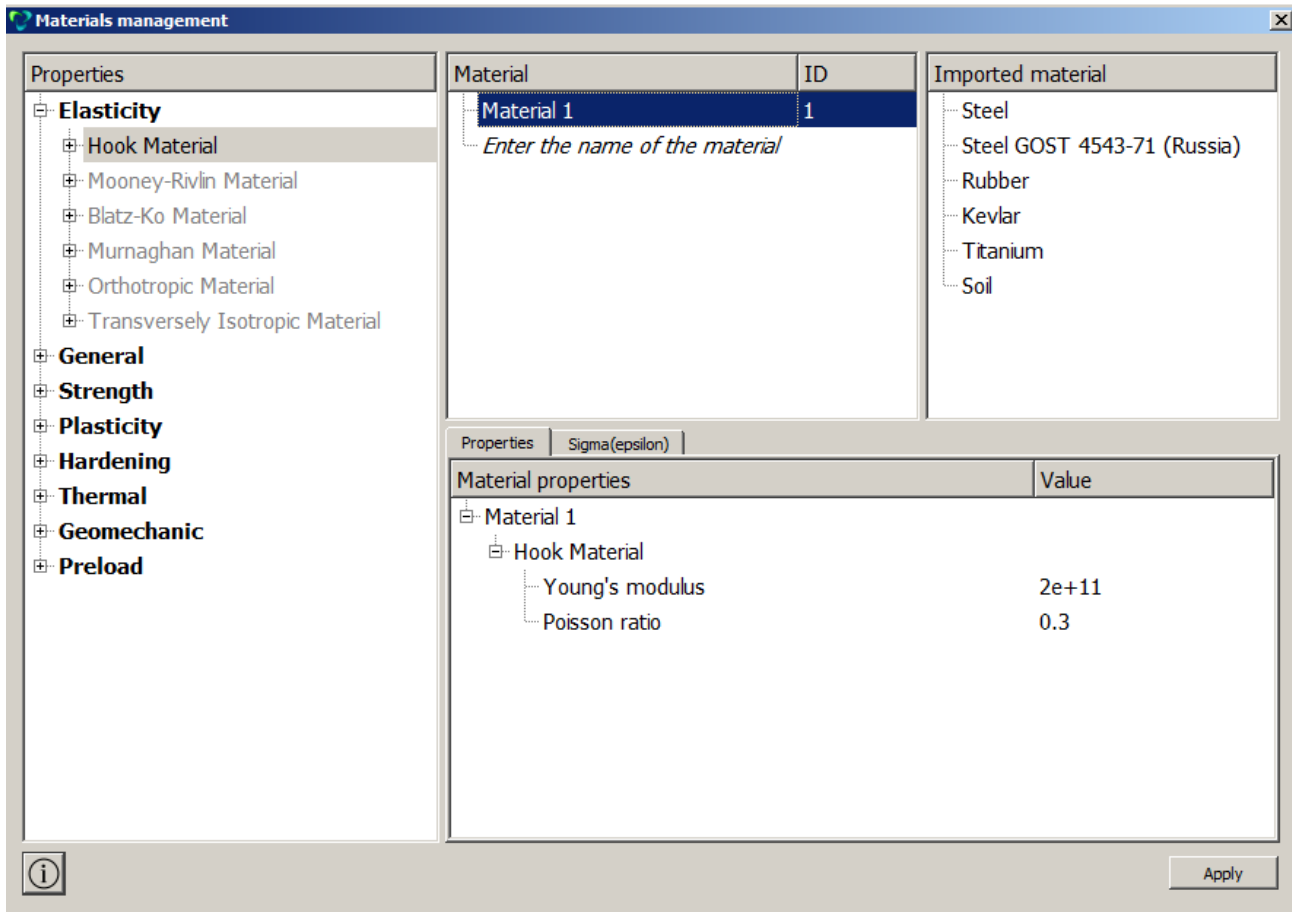

2. Create the block of one type of the material.

Select setting the material properties section on Command Panel (Mode — **Blocks**, Entity — **Block**, Action — **Add**). Set the following parameters:

- Block ID: 1;
- Entity list: Surface;
- Entity ID(s): 1 (or by the command *all*).

Click **Apply**.

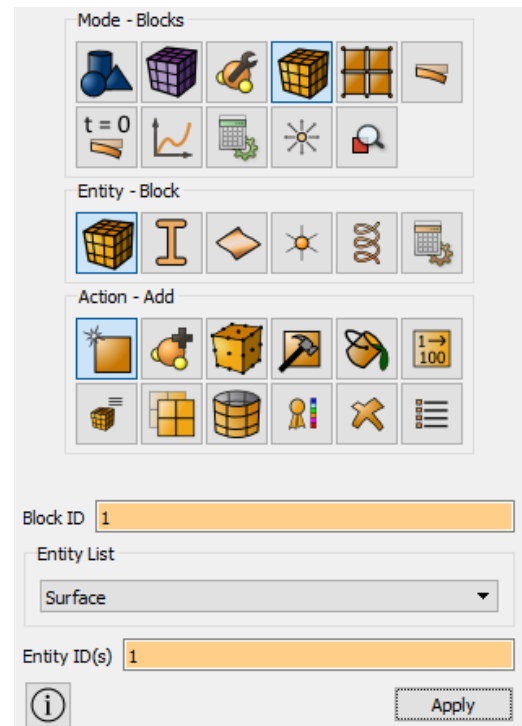

3. Assign the material to the block.

Select setting the material properties section on Command Panel (Mode — **Blocks**, Entity — **Block**, Action — **Set material**). Set the following parameters:

- Block ID(s): 1;
- Select the previously created material in the list: Material 1.

Click **Apply**.



4. Assign the element type.

Select setting the material properties section on Command Panel (Mode — **Blocks**, Entity — **Block**, Action — **Element types**). Set the following parameters:

- Block ID(s): 1;
- Category: Shell;
- Order:1.

Click **Apply**.

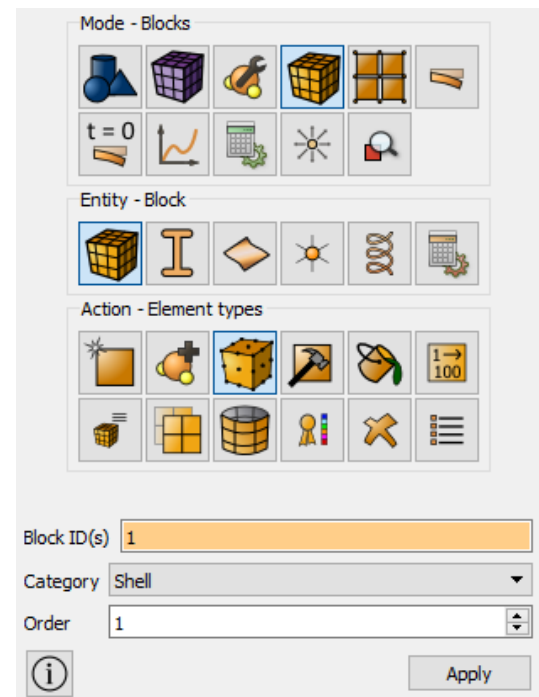

5. Setting shell thickness

Select setting the material properties section on Command Panel (Mode — **Blocks**, Entity — **Shell Properties**). Select in the list of possible operations. Set the following parameters:

- Block ID: 1;
- Thickness: 0.1;
- Eccentricity: 0.5;

Click **Apply**.

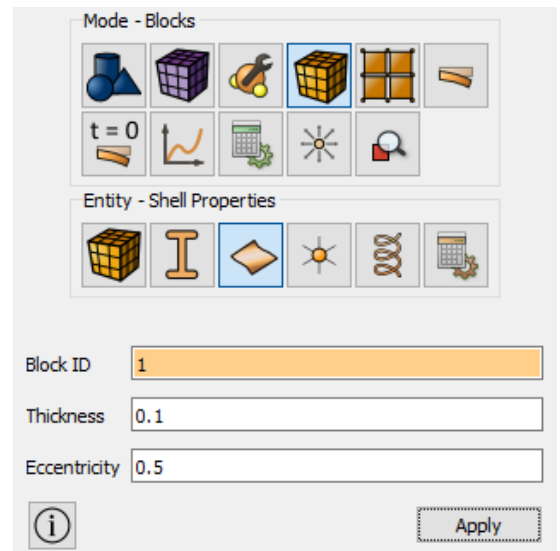

Starting calculation

1. Set the type of the problem to be solved.

Select calculation setting section on Command Panel (Mode — **Calculation settings**, Calculation settings — **Static**, Static — **General**). Select:

- Dimension: 3D;
- Model: Elasticity.

Click **Apply**.

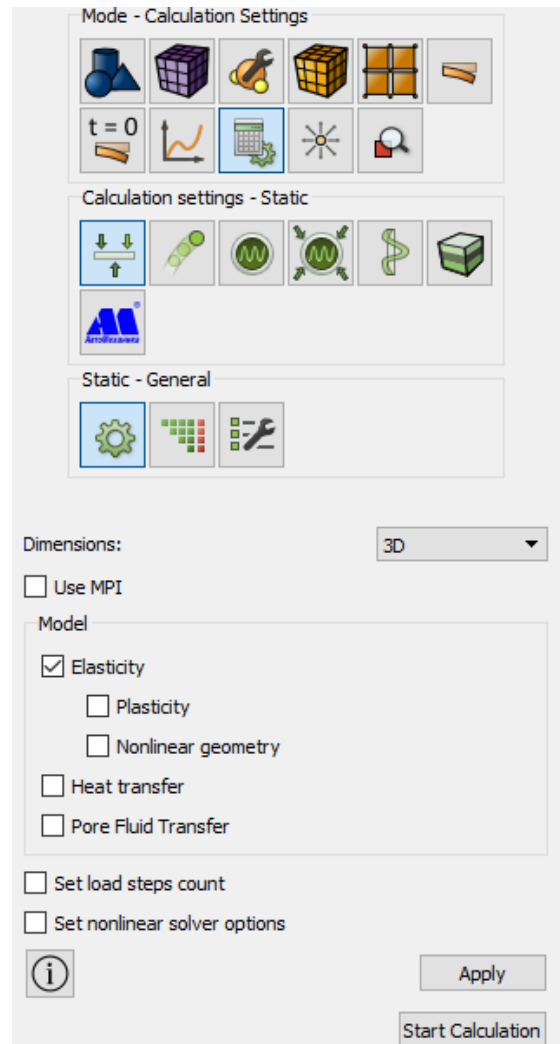

2. Set the solver settings.

Select calculation setting section on Command Panel (Mode — **Calculation settings**, Calculation settings — **Static**, Static — **Solver**). Select the solver method (direct or iterative) and set Convergence Parameters in case of choosing an iterative one. You can also leave all the settings by default. Click **Apply**.

3. Set the reaction force calculation

Go to the tab Static – **Output fields** and set the checkbox **Calculate nodal and reaction forces**.

Click **Apply**.

Click **Start Calculation**.

Note: Without setting the checkbox **Calculate nodal and reaction forces**, the field is not calculated.

4. In a pop-up window select a folder to save the result and enter the file name.

- If the calculation is finished successfully, you will see a message in the Console: "*Calculation finished successfully at <date> <time>*".

Results analysis

- Open the file with the results. You can do this in one of the three ways.

- Click Ctrl+E.
- Select Calculation → Open Results in the Main Menu. Click **Open last result**.
- Select **Results** on Command Panel (Mode — **Results**). Click **Open Results**.

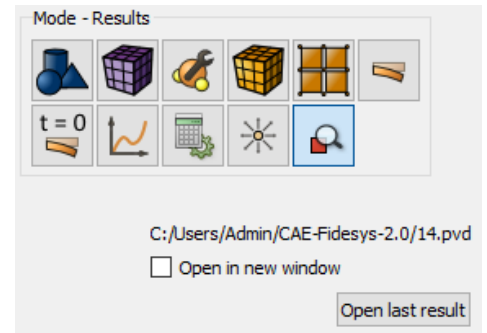

- Display the u_z component of the displacement field.

In **Fidesys Viewer** window set the following parameters on Toolbar:

- Representation Mode: Surface;
- Representation Field: Displacement;
- Representation Component: Z.



The field of displacements distribution along the Z axis will be displayed on the model

- Check the numerical value of the maximum displacement.

Display maximum Component 3 of the Displacement field.

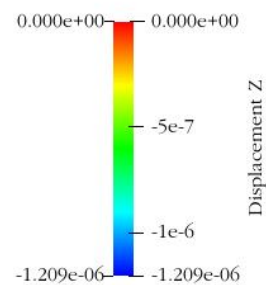
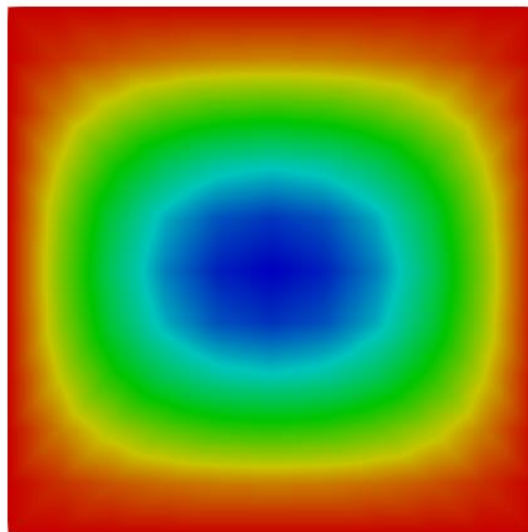

The difference between the resulting value $1.209e-6$ and the required $-1.19e-6$ is 1.6%

- Check numeric values of moments in the center of the plate.

Display component XX of the MomentsShell field.

Select the filter **Probe Location** (Filters – Alphabetical – Probe Location) in the **Fidesys Viewer** Main Menu. In the tab **Properties** set the following values:

- Point: (0,0,0);
- Number of Points: 1;
- Radius: 0.

Go to the **Information** tab and look at the MomentsShell field.

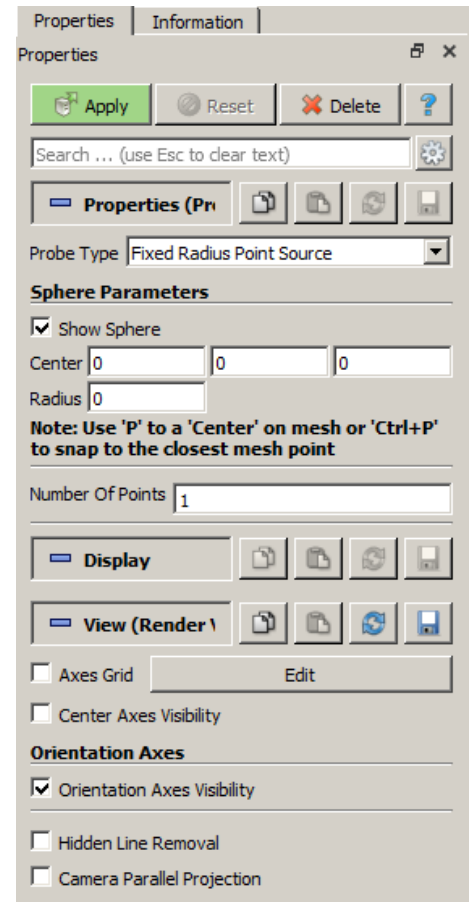

Data Arrays

Current data time: 1

Name	Data Type
Displacement	[-2.88229e-24, 2.88229e-24], [-5.40845e-24, 5.40845e-24]
External Force	[0, 0], [0, 0], [-100, 0]
External Moment	[0, 0], [0, 0], [0, 0]
MiddleSurfaceForces	[-8.604e-13, 1.10133e-12], [-1.22249e-12, 6.2029e-13]
MomentsShell	[260.347, 260.347], [344.745, 344.745] [0, 0], [0, 0]
Nodal Force	[-8.27251e-14, 8.27251e-14], [-5.54029e-14, 5.54029e-14]
Nodal Moment	[-68.3822, 68.3822], [-7.39829, 7.39829], [0, 0]
Node ID	[1, 121]
Normal	[0, 0], [0, 0], [1, 1]

The difference between the resulting values ($M_x=260.347$ and $M_y=344.745$) and the required ($M_x=252$ and $M_y=332$) is 3.3% and 3.8%, relatively.

5. Open 3D-image of the shell.



To display 3D-view of the beam cross section, set the focus on the calculation title and click the button 3D-view in the Fidesys Viewer standard line.

A new file example *.pvd will be opened and you will be able to apply various filters to it and to view its deformed view.

Choose the new file example_3D.pvd in the Model Tree and display Filters – Alphabetical – **Warp by Vector** for it with the following fields values

- **Vectors:** Displacement
- **Scale Factor:** 2e5

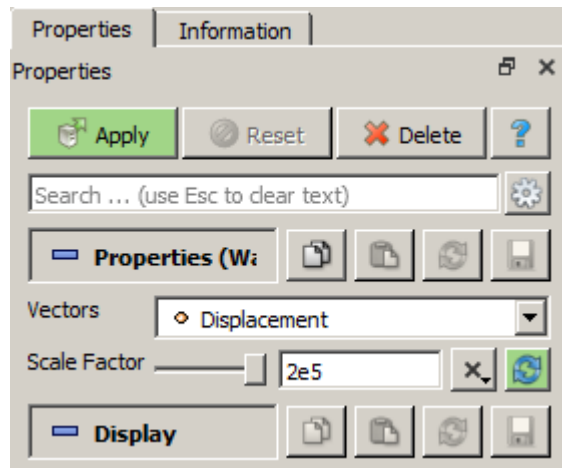

On the Toolbar, set once again the following parameters for the deformed type:



The first buckling mode will be displayed on the screen but the shell will be enveloped with thickness.

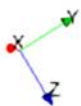
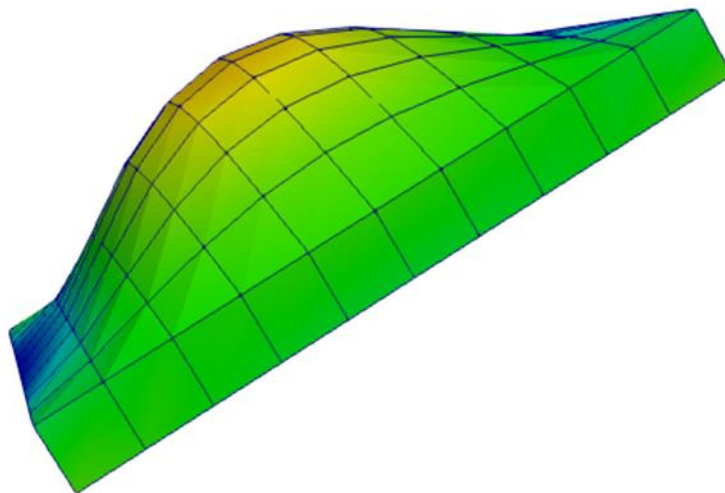

To apply all of the filters changes automatically, click **Apply changes to parameters automatically** on Command Panel.

6. Download numerical data.

Select **File** → **Save Data** in the Main Menu or click **Ctrl+S**. Enter the file name (*.csv format), leave it by default. Click **OK**. The saved file is an ordinary table of numerical data which can be opened in any text editor.

Using Console Interface

For geometry generation, meshing, setting boundary conditions and materials you can use Console Interface. The following program code allows performing the steps of the above-described guide, you only need to **manually specify the full path and name of the file to be saved**.

```
reset
create surface rectangle width 1 zplane
surface 1 scheme polyhedron
mesh surface 1
create displacement on curve 1 3 dof all fix 0
create displacement on curve 2 4 dof 1 dof 2 dof 3 fix 0
create pressure on surface 1 magnitude 1e4
create material 1
modify material 1 name 'Material1'
modify material 1 set property 'MODULUS' value 2e+11
modify material 1 set property 'POISSON' value 0.3
block 1 add surface 1
block 1 material 1
block 1 element shell
block 1 attribute count 2
block 1 attribute index 1 value 0.1 name 'thickness'
block 1 attribute index 2 value 0.5 name 'eccentricity'
analysis type static elasticity dim3
solver method auto use_uzawa auto try_other on
output nodalforce on energy off midresults on record3d on log on vtu on material off
calculation start path "D:/Fidesys/example.pvd"
```



It is also possible to run the file *Example_4_Static_Shell.jou* by selecting Journal Editor on Toolbar. In a pop-up window of the main menu select **File** → **Open** and open the necessary journal file.

Hydrostatic pressure on cylinder (setting boundary conditions according to coordinates)

Societe Francaise des Mecaniciens, Guide de validation des progiciels de calcul de structures, (Paris, Afnor Technique, 1990.) Test No. SSLSo8/89. I-Deas Model Solution Verification Manual

The problem of hydrostatic load of the cylindrical shell is being solved. The picture represents a geometric model of the problem: radius 1 m, shell thickness 0.02 m. The shell is fixed on the condition of the symmetry. The plate is loaded by the pressure $p = 20000 \cdot z/L$ Pa.

Test pass criterion is the following: displacement u_z at the point (0, R, L) is $2.86 \cdot 10^{-6}$ m.

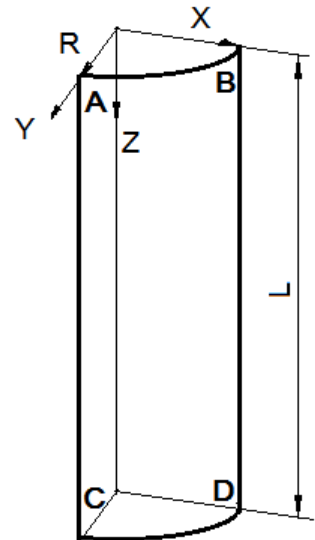

Geometry creation

1. Create the cylinder of 1 m radius and 4 m high.

Select volume geometry generation section on Command Panel (Mode — **Geometry**, Entity — **Volume**, Action — **Create**). Select **Cylinder** in the list of geometric elements. Specify the cylinder dimensions:

- Height: 4;
- Cross section: Circular;
- Radius: 1.

Click **Apply**.

2. Get the cylindrical shell out of the volumeric cylinder.

Select the volume removing section on Command Panel (Mode — **Geometry**, Entity — **Volume**, Action — **Delete**). Enter the number of the created volume – 1 into the field **Volume ID(s)**.

Put a tick against **Keep lower geometry**.

Click **Apply**.

As a result, three plane bodies (Body 2, Body 3, Body 4) are obtained. This will be displayed in the Model Tree.

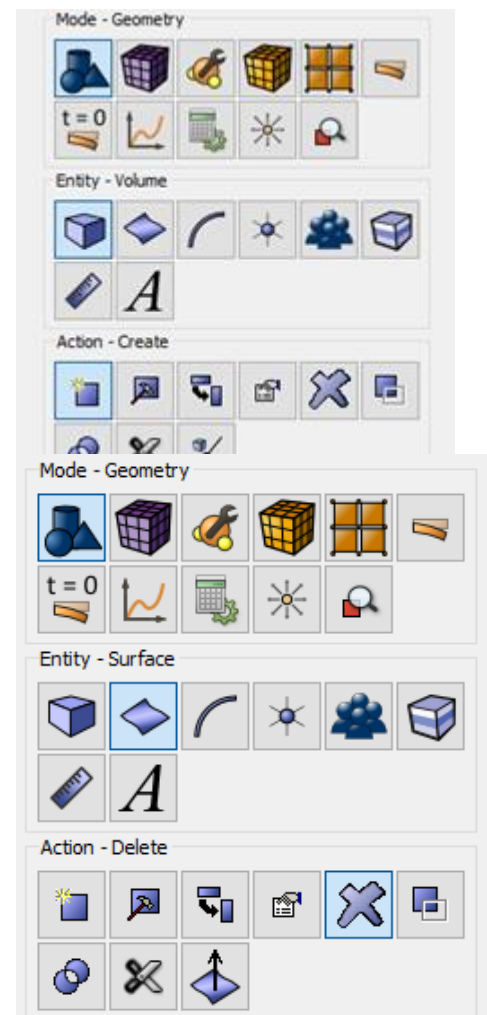

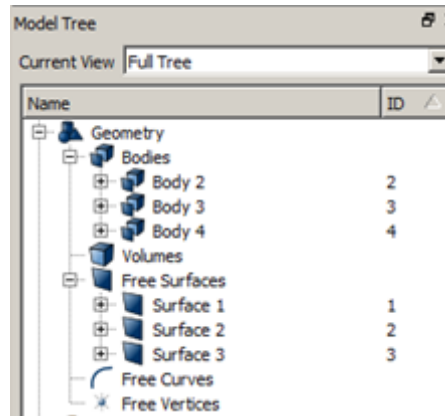

3. Delete side surfaces Surface 2 and Surface 3.

Select the surface removing section on Command Panel (Mode — **Geometry**, Entity — **Surface**, Action — **Delete**). Enter numbers – 2 3 in the window **Surface ID(s)**.

Click **Apply**.

As a result, only the lateral cylindrical shell of 1 m radius and 4 m high will remain of the initial volume.

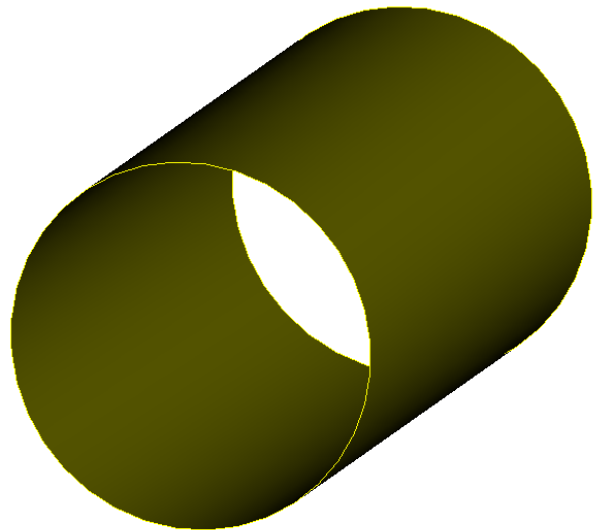
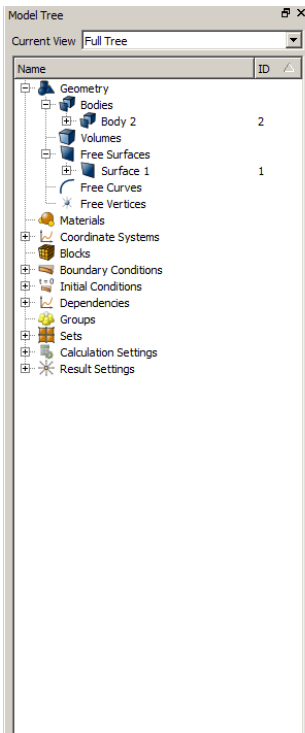

4. Leave a quarter of a shell (symmetric problem).

Select volume geometry generation section on Command Panel (Mode — **Geometry**, Entity — **Volume**, Action — **Webcut**). Select **Plane** in the list of possible webcut types. Set the following parameters:

- Body ID: 2 (the body to be webcut);
- Webcut with: YZ Plane;
- Offset value: 0.

Click **Apply**.

Do the same for the ZX Plane.

- Body ID: 2 (the body to be webcut);
- Webcut with: ZX Plane;
- Offset value: 0.

Click **Apply**.

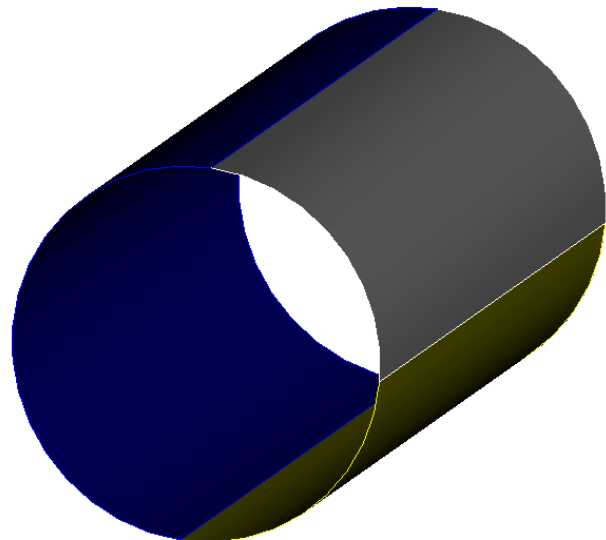
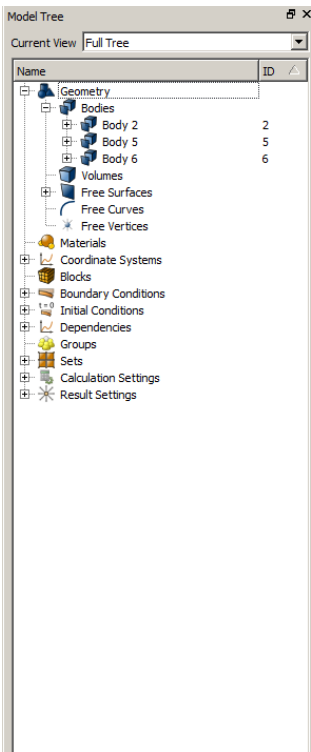
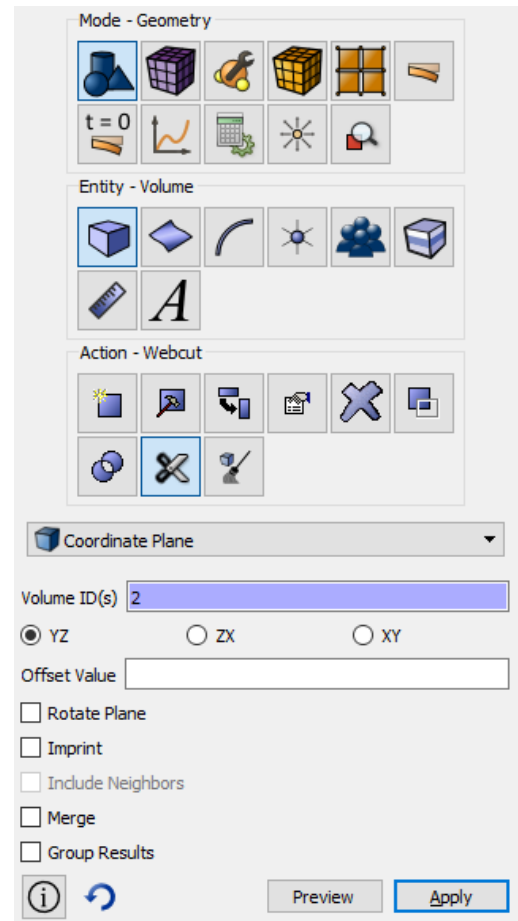

As a result, the original Body 2 in the Model Tree is split into three (Body 2, Body 5 and Body 6).

5. Delete surfaces Surface 5 and Surface 6.

Select the surface removing section on Command Panel (Mode — **Geometry**, Entity — **Surface**, Action — **Delete**). Enter numbers — 5 6 into the window **Surface ID(s)**.

Click **Apply**.

As a result, only a quarter of the original shell Body 6 (Surface 7) is left.

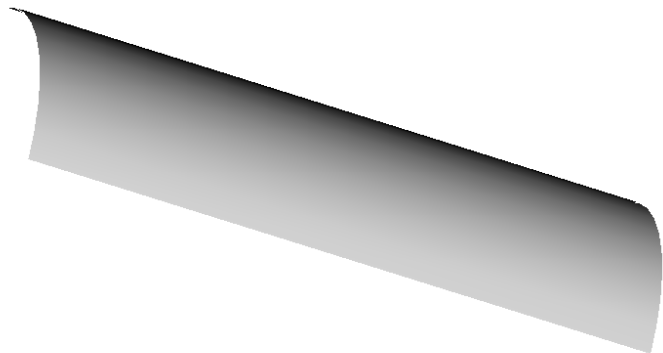
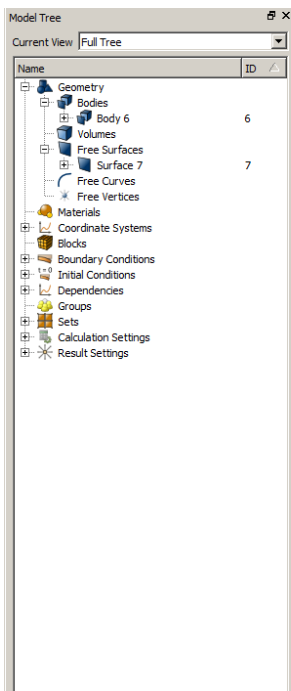

6. Move the surface to the coordinate origin.

Select surface geometry modification section on Command Panel (Mode — **Geometry**, Entity — **Surface**, Action — **Transform**). Select **Move** in the list of possible webcut types. Set the following parameters:

- Surface: 7 (the surface to be moved);
- Checkbox Distance;
- Z Distance: 2.

Click **Apply**.

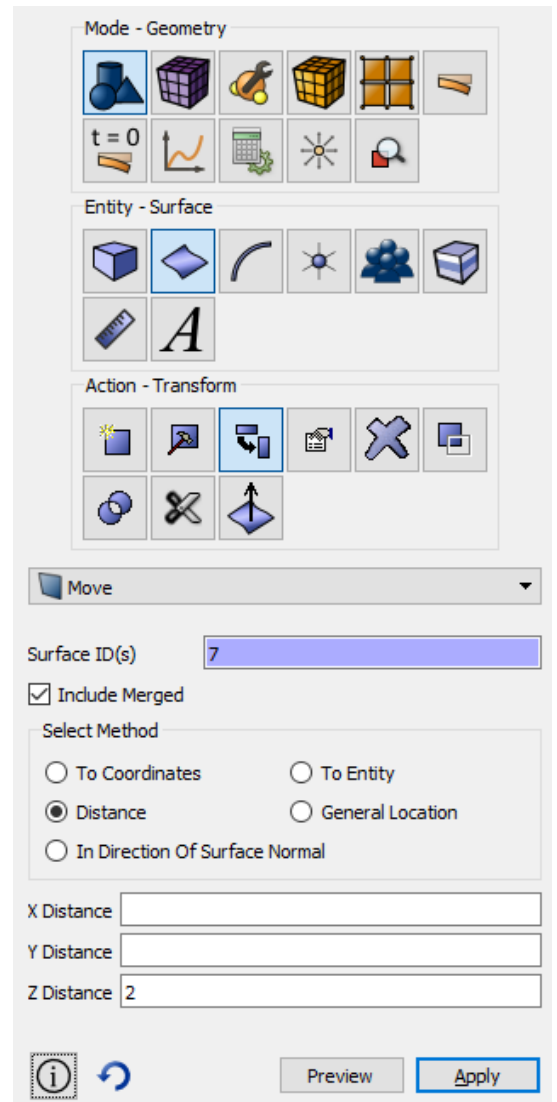

Meshing

1. Specify the parameters of mesh refinement.

Select meshing on curves section on Command Panel (Mode — **Mesh**, Entity — **Curve**, Action — **Mesh**).

Split the cross-cut curves Surface 17 and Surface 18 into 10 elements.

- Select Curves: 17 18 (or click the mouse while holding down the Ctrl key on contour of the cross-cut curves);
- Select the way of meshing: Equal;
- Select splitting settings: Interval;
- Specify interval number: 10.

Click **Apply Size**.

Split longitudinal curves Curve 5 and Curve 16 into 20 elements.

- Select Curves: 5 16 (or click the mouse while holding down the Ctrl key on contour of the longitudinal curves);
- Select the way of meshing: Equal;
- Select splitting settings: Interval;
- Specify interval number: 20.

Click **Apply Size**.

2. Create the mesh.

Select the surface mesh generation section on Command Panel (Mode — **Mesh**, Entity — **Surface**, Action — **Intervals**).

- Select Surfaces to Mesh (specify their ID): 7 (or by the command *all*);
- Select meshing scheme: Automatic Sizing.

Click **Apply Size**.

Click **Mesh**.

The resulting number of elements can be viewed in the Property Page by clicking on the inscription Surface 7 in the Model Tree on the left.

To view the mesh properties, you can follow these steps:

- Select the entire model
- Right-click on the model
- In the pop-up menu, select List Information – List Mesh Info
- Information on the mesh will be displayed in Command Line

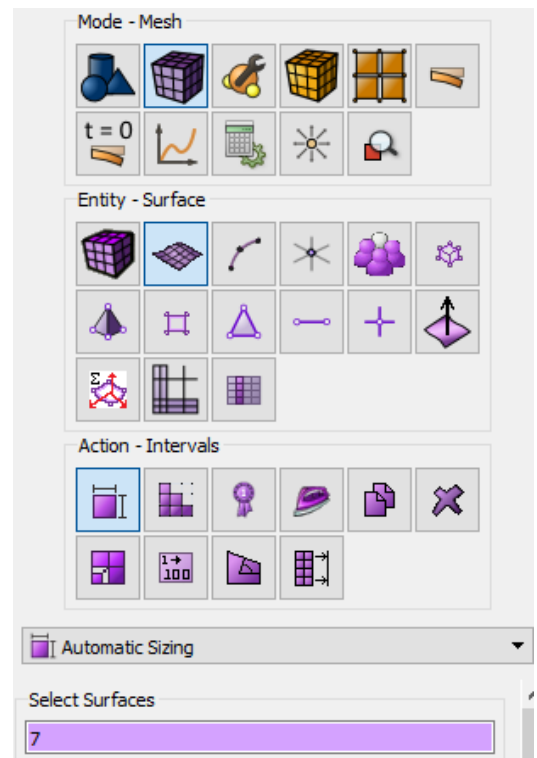
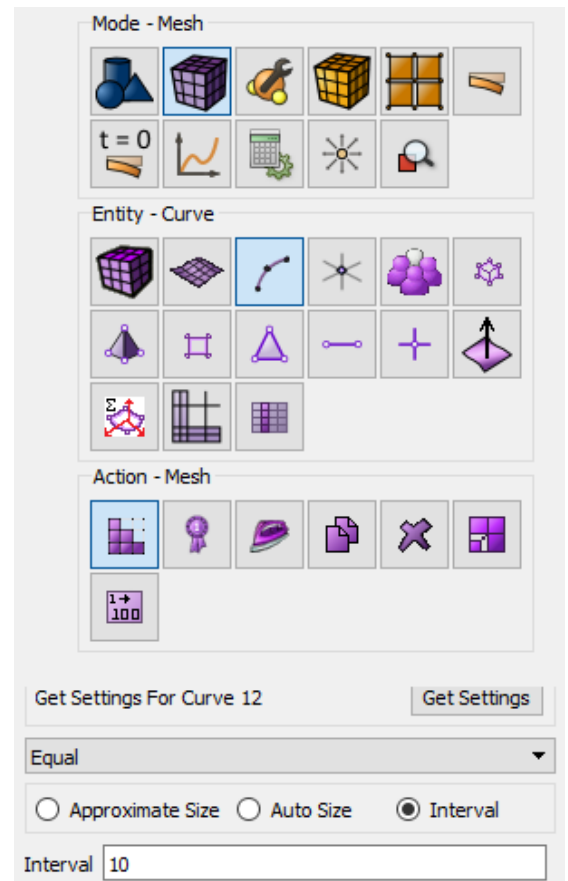

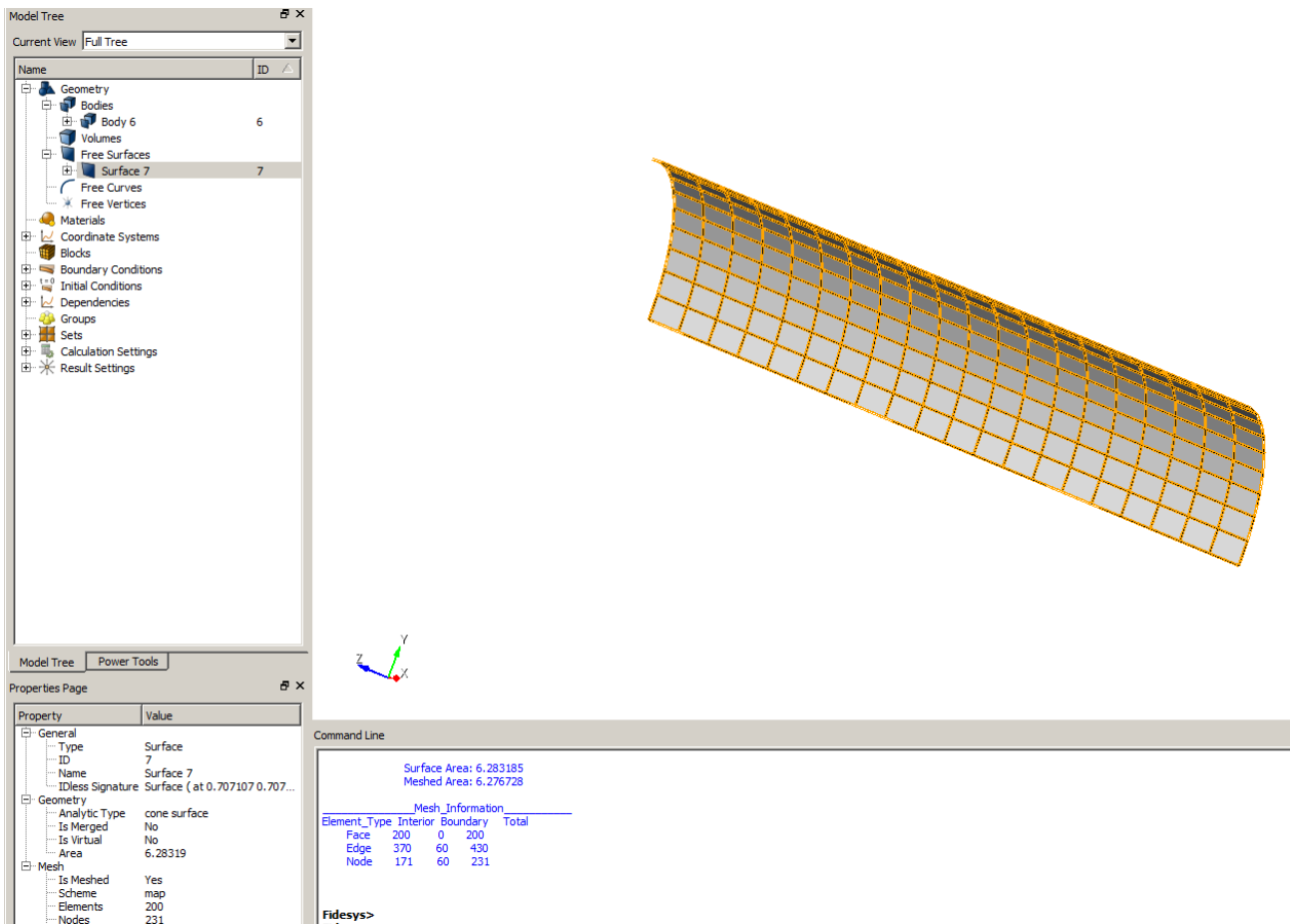

Setting material and element type

1. Create the material.

Select setting the material properties section on Command Panel (Mode — **Material**, Entity — **Materials management**).

In the Materials Management window that opens, in the second column, click on the caption Enter the name of the material and write "Material 1". Press the ENTER key.

In the left column, select Elasticity - Hooke Material. Select with the mouse the characteristic Young's modulus. Hold down the left mouse button and drag the label to Material Properties. Double-click in the Value field next to Young's modulus and enter the number $2.1e11$. Similarly, from the Hooke Material section add the Poisson Ratio 0.3.

Click **Apply**.

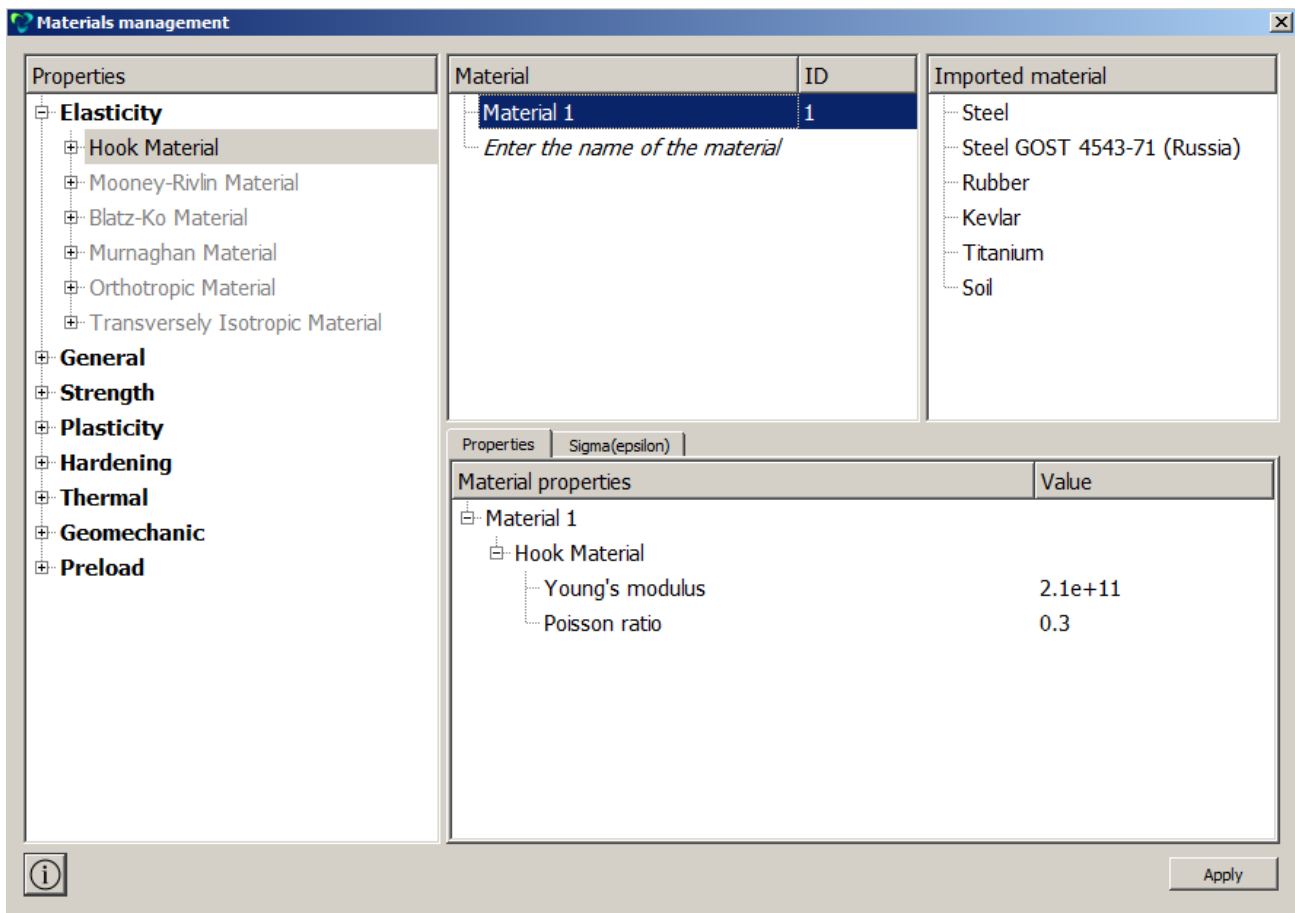

2. Create the block of one type of the material.

Select setting the material properties section on Command Panel (Mode — **Blocks**, Entity — **Block**, Action — **Add**). Set the following parameters:

- Block ID: 1;
- Entity List: Surface;
- Entity ID(s): 7 (or by the command all).

Click **Apply**.

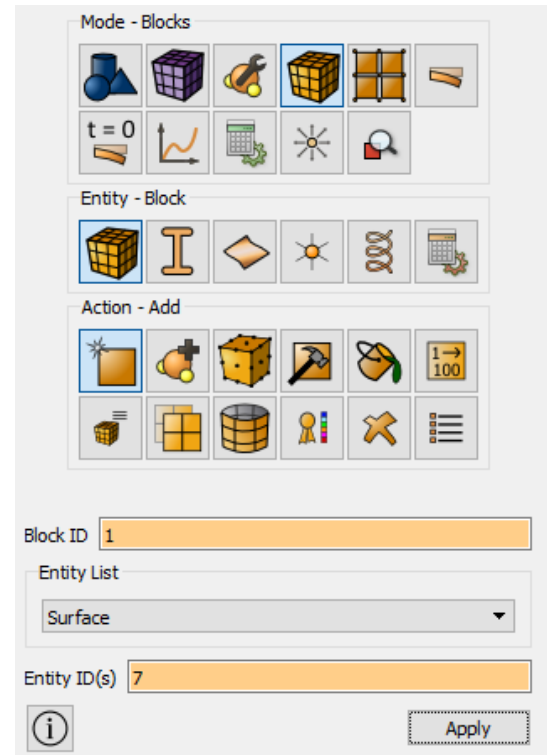

3. Assign the material to the block.

Select setting the material properties section on Command Panel (Mode — **Blocks**, Entity — **Block**, Action — **Set material**). Set the following parameters:

- Block ID(s): 1;
- Select the previously created material in the list: Material 1.

Click **Apply**.

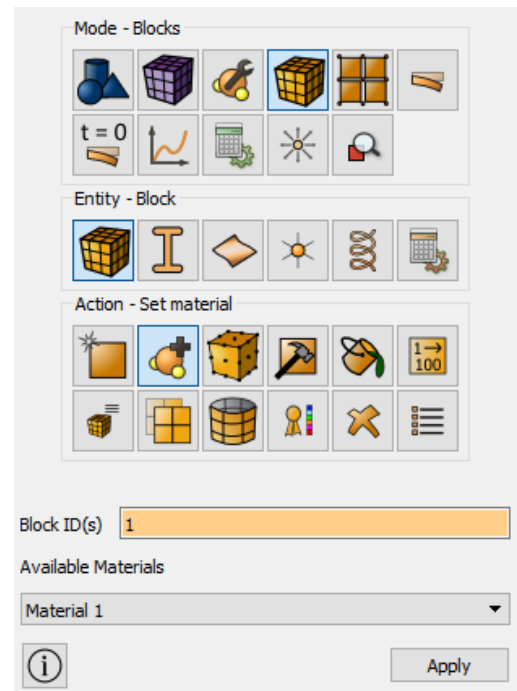

4. Assign the shell thickness.

Select setting the material properties section on Command Panel (Mode — **Blocks**, Entity — **Shell properties**). Set the following parameters:

- Block ID: 1;
- Thickness: 0.02;
- Eccentricity: 0.5.

Click **Apply**.

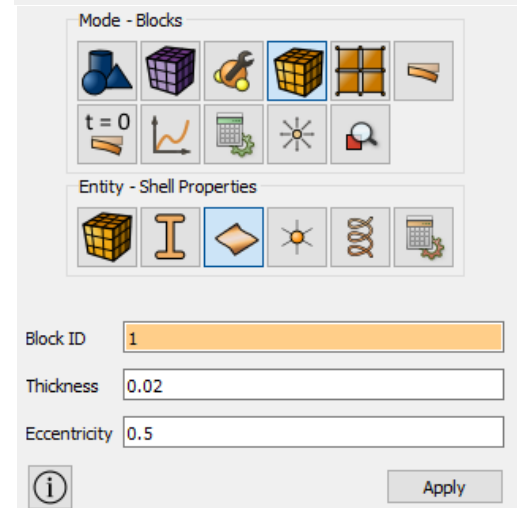

5. Assign the element type to the block.

Select setting the material properties section on Command Panel (Mode — **Blocks**, Entity — **Block**, Action — **Element types**). Set the following parameters:

- Block ID(s): 1;
- Category: Shell;
- Order: 1.

Click **Apply**.

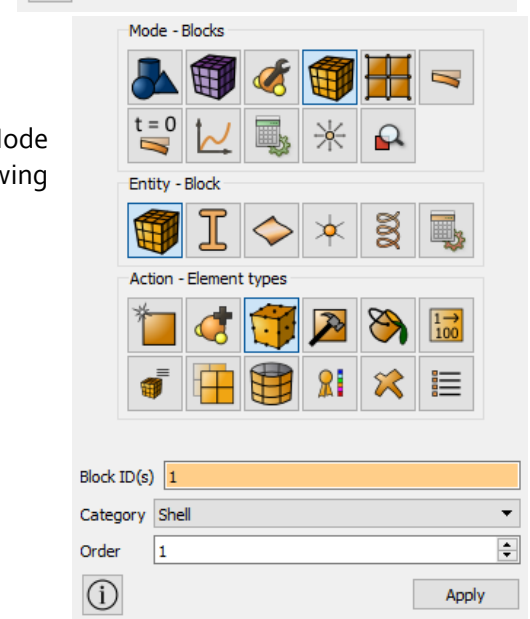

Setting boundary conditions

1. Fix the cross-cut curve Surface 17 by the symmetry condition.

Select Mode — **Boundary Conditions**, Entity — **Displacement**, Action — **Create** on Command Panel. Set the following parameters:

- System Assigned ID;
- Entity List: Curve;
- Entity ID(s): 17 (or click on the cross-cut curve);
- Degrees of Freedom: Z-Translation Disp; X-Rotation Disp; Y-Rotation Disp.

Click **Apply**.

2. Fix the longitudinal curve Curve 5 on the symmetry condition.

Select Mode — **Boundary Conditions**, Entity — **Displacement**, Action — **Create** on Command Panel. Set the following parameters:

- System Assigned ID;
- Entity List: Curve;
- Entity ID(s): 5 (or click on the longitudinal curve);
- Degrees of Freedom: X-Translation Disp; Y-Rotation Disp; Z-Rotation Disp.

Click **Apply**.

3. Fix the longitudinal curve Curve 16 by the symmetry condition.

Select Mode — **Boundary Conditions**, Entity — **Displacement**, Action — **Create** on Command Panel. Set the following parameters:

- System Assigned ID;
- Entity List: Curve;
- Entity ID(s): 16 (or click on the longitudinal curve);
- Degrees of Freedom: Y-Translation Disp; X-Rotation Disp; Z-Rotation Disp.

Click **Apply**.

Mode - Boundary Conditions

Entity - Displacement

Action - Create

ID/Name

New ID

Name

System Assigned ID

Entity List

Nodeset Volume Surface Curve

Hex Tet Face Vertex

Tri Edge Node

Entity ID(s) 17

Degrees Of Freedom

All

X-Translation Disp X-Rotation Disp

Y-Translation Disp Y-Rotation Disp

Z-Translation Disp Z-Rotation Disp

DOF Value

Specify Combination!

Overwrite Average

Smallest Largest

4. Apply pressure to the cylinder inner surface with value of 1.

Select Mode — **Boundary Conditions**, Entity — **Pressure**, Action — **Create** on Command Panel. Set the following parameters:

- System Assigned ID;
- Entity List: Surface;
- Entity ID(s): 7 (or click on the cylinder surface);
- Magnitude Value: 1.

Click **Apply**.



5. Set pressure dependency of the z-coordinate.

Select Mode — **BC Dependence**.

In the pop-up window **BC Dependence**, set the following parameters:

- BC name: Pressure 1;
- Select checkbox Formula, Manually;
- In the field below, enter $-20000*z/4$.

Click **Apply**.

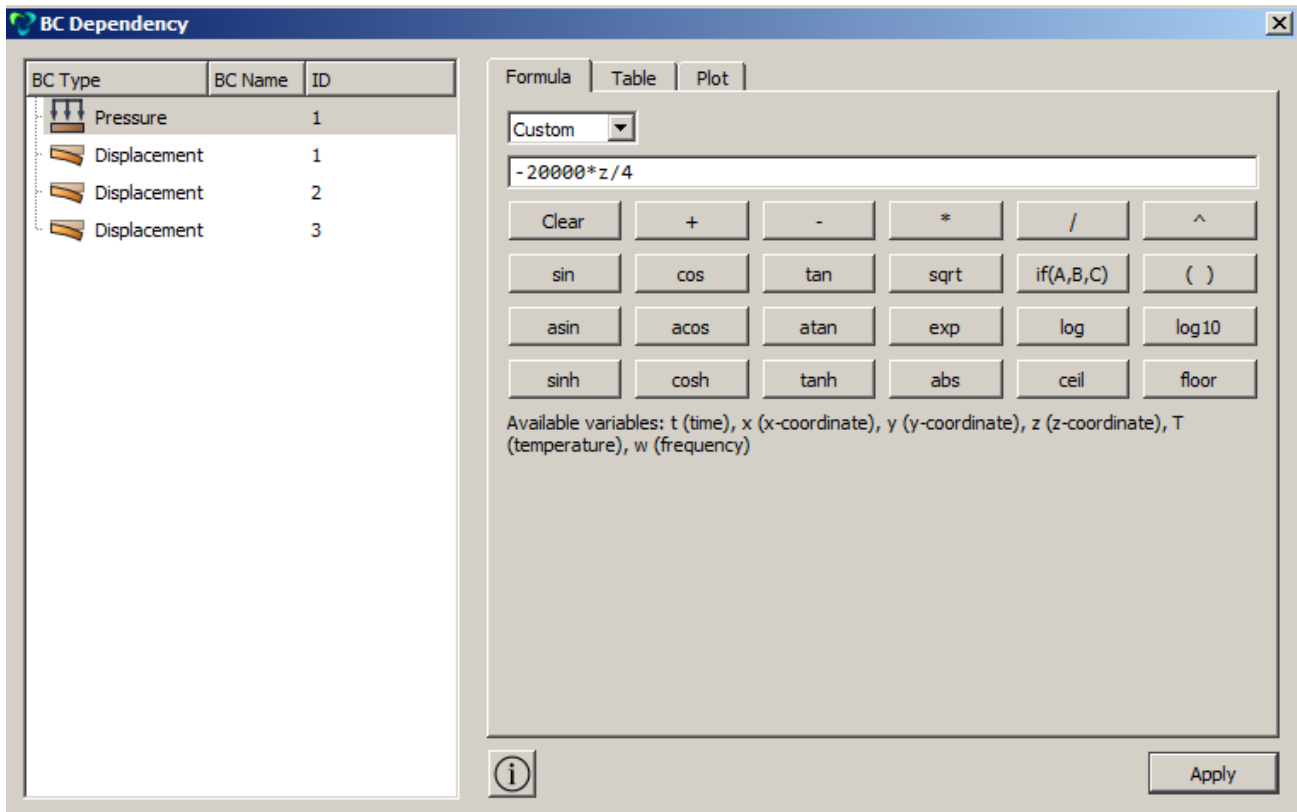
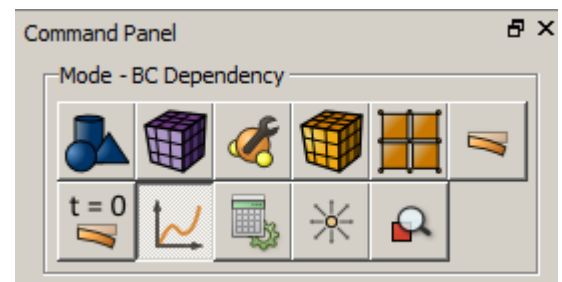



To view the plotted graph, please, use the appropriate tab.

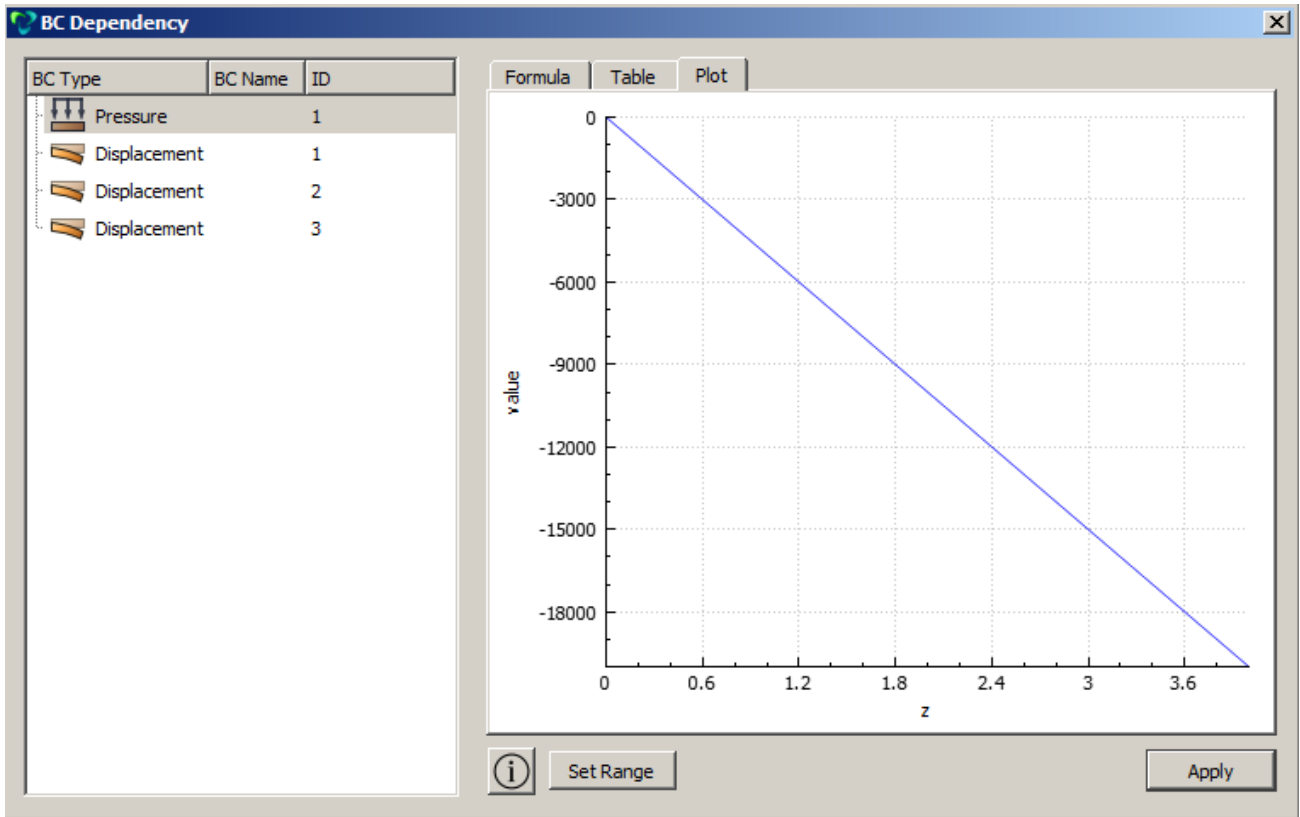

Starting calculation

1. Set the type of the problem to be solved.

Select calculation setting section on Command Panel (Mode — **Calculation settings**, Calculation settings — **Static**, Static — **General**). Select:

- Dimension: 3D;
- Model: Elasticity.

Click **Apply**.

Click **Start Calculation**.

In a pop-up window select a folder to save the result and enter the file name.

If the calculation is finished successfully, you will see a message in the Console: "*Calculation finished successfully at <date> <time>*".

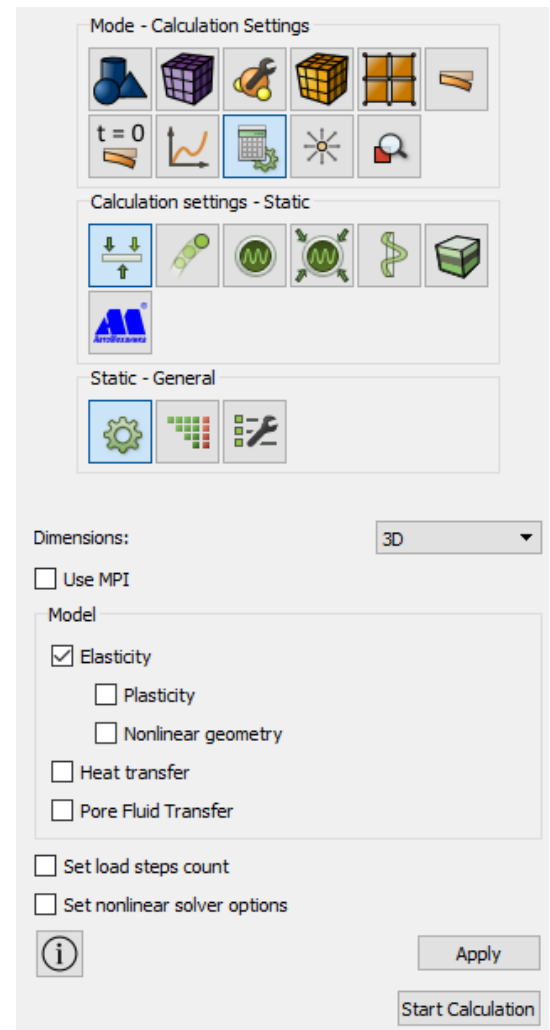

Results analysis

- Open the file with the results. You can do this in one of the three ways.
 - Click Ctrl+E.
 - Select **Calculation** → **Open Results** in the Main Menu. Click **Open last result**.
 - Select **Results** on Command Panel (**Mode** — **Results**). Click **Open Results**.
 - Display the Uz component of the displacement field on the model.
- In **Fidesys Viewer** window set the following parameters on Toolbar:
- Representation Mode: Surface;
 - Representation Field: Displacement;
 - Representation Component: 3.
- Compare the numerical value of the target displacement at the point (0,1,4) with the initial one of the source -2.86e-6.

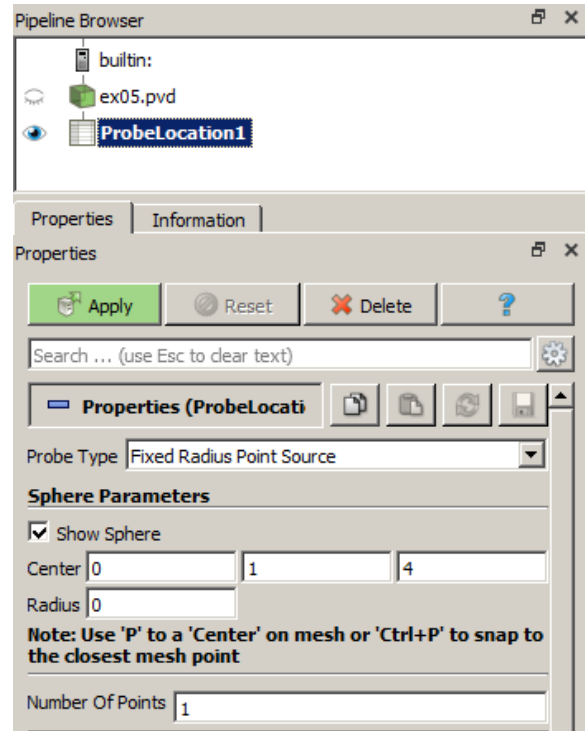

Select **Filters** → **Alphabetical** → **Probe Location**. In the tab **Properties**, set the following parameters for the filter:

- Point (0, 1, 4);
- Number of Points: 1;
- Radius: 0.

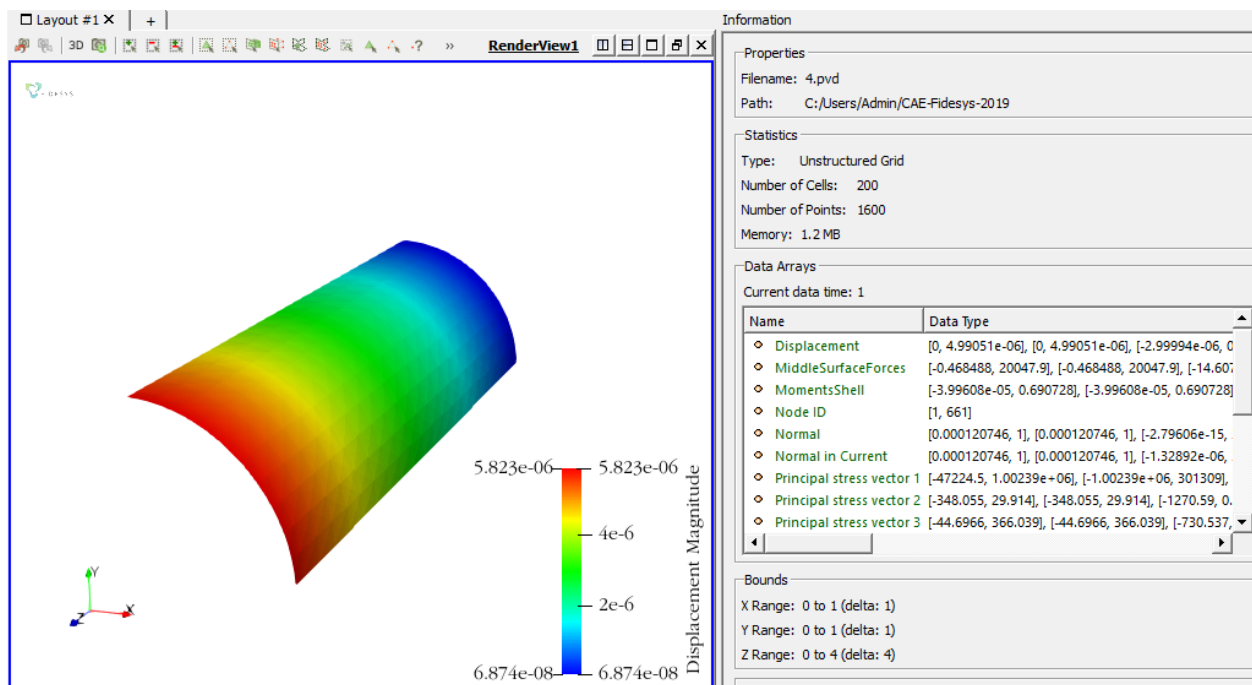

The difference between the resulting value -2.99994e-06 and the required -2.86e-6 is 4.89%.

You can see the way the body is deformed under the applied pressure.

Select the filter **Warp By Vector** to do this. Set the following parameters in the tab **Properties**:

- Vectors: Displacement;
- Scale Factor: 1e5.

As a result, the deformed body is displayed at the picture.

Select the following display settings for the deformed view:



To see the original model, click the icon  near the model in the Model Tree.

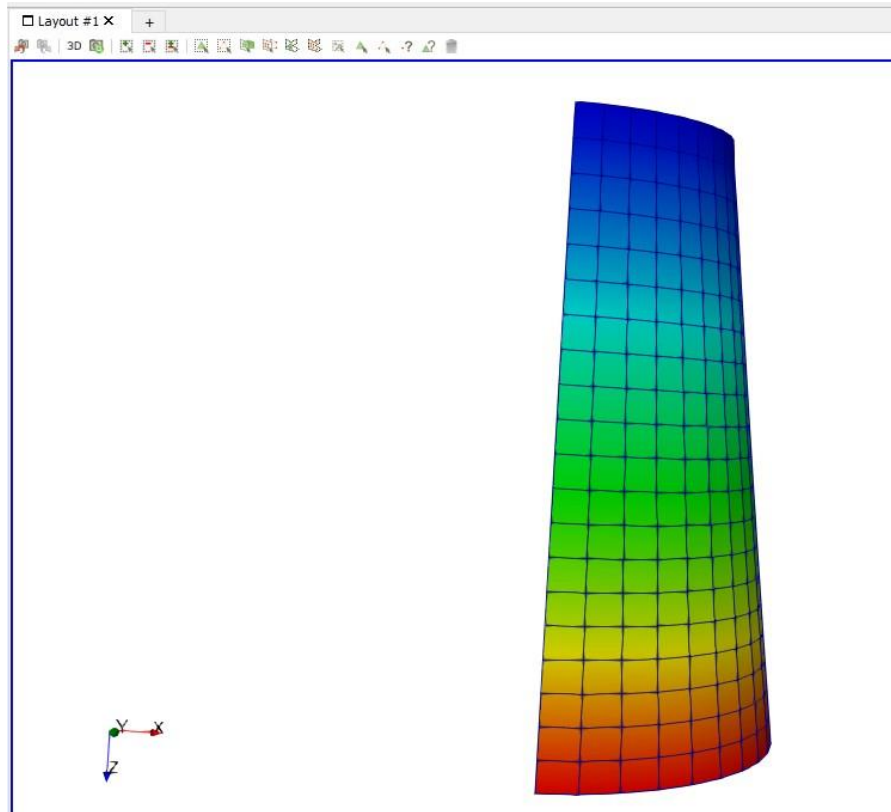

Consider the direction of the coordinate axes in the picture.

4. Download numerical data.

Select **File** → **Save Data** in the Main Menu or click **Ctrl+S**. Enter the file name (*.csv format), leave it by default. Click **OK**. The saved file is an ordinary table of numerical data which can be opened in any text editor.

Using Console Interface

For geometry generation, meshing, setting boundary conditions and materials you can use Console Interface. The following program code allows performing the steps of the above-described guide, you only need to **manually specify the full path and name of the file to be saved**.

```
reset
set node constraint on
create Cylinder height 4 radius 1
delete volume 1 keep_lower_geometry
delete Surface 2 3
webcut body 2 with plane xplane offset 0 preview
webcut body 2 with plane xplane offset 0
webcut body 2 with plane yplane offset 0 preview
webcut body 2 with plane yplane offset 0
delete Surface 5 6
move Surface 7 preview z 2 include_merged
move Surface 7 z 2 include_merged
curve 17 18 interval 10
curve 17 18 scheme equal
curve 5 16 interval 20
curve 5 16 scheme equal
surface all size auto factor 5
mesh surface all
list Surface 7 mesh
create material 1
modify material 1 name 'material 1'
modify material 1 set property 'POISSON' value 0.3
modify material 1 set property 'MODULUS' value 2e+11
set duplicate block elements off
block 1 surface 7
block 1 material 'material 1'
block 1 element type shell8
undo group begin
block 1 attribute count 2
block 1 attribute index 1 value 0.02
block 1 attribute index 2 value 0.5
undo group end
block 1 element shell order 2
create displacement on curve 17 dof 3 dof 4 dof 5 fix
create displacement on curve 5 dof 1 dof 5 dof 6 fix
create displacement on curve 16 dof 2 dof 4 dof 6 fix
create pressure on surface 7 magnitude 1
bcdep pressure 1 value '-20000*z/4'
analysis type static elasticity dim3
calculation start path "D:/Fidesys/example.pvd"
```



It is also possible to run the file *Example_5_Static_3D_Shell.jou* by selecting Journal Editor on Toolbar. In a pop-up window of the main menu select **File** → **Open** and open the necessary journal file.

Buckling (shell model)

S.P. Timoshenko, J.M. Gere "Theory of elastic stability" second edition. Dunod, 1966, 500 pages

The problem of cylindrical shell buckling under the pressure uniformly distributed over the entire surface is being solved.

The picture represents a geometric model of the problem: $R = 2\text{ m}$, $L = 2\text{ m}$, thickness $h = 0.002\text{ m}$. Due to the symmetry of the problem, the $\frac{1}{4}$ part of the cylinder is regarded. Constraints on the lines AB and CD are due to the conditions of symmetry; a uniformly distributed load on the surface is ABCD $q = 1\text{ kPa}$. The material parameters are $E = 200\text{ GPa}$, $\nu = 0.3$.

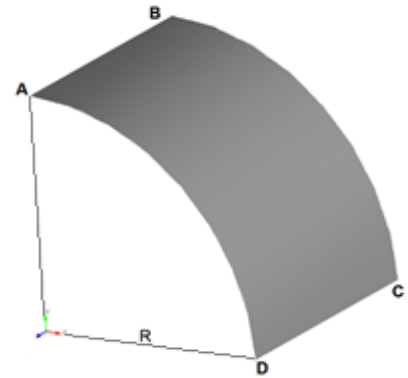

It is necessary to compare the first three critical values.

Geometry creation

1. Create a cylinder with radius of 2 m and length of 2 m.

Select volume geometry generation section on Command Panel (Mode — **Geometry**, Entity — **Volume**, Action — **Create**). Select **Cylinder** in the list of geometric elements. Create leaving **Circular** at the base. Set radius of 2 and height of 2

Click **Apply**.

2. Get the cylindrical shell out of the volumeric cylinder.



Select the volume removing section on Command Panel (Mode — **Geometry**, Entity — **Volume**, Action — **Delete**). Enter the number of the created volume – 1 into the field **Volume ID(s)**. Put a tick against **Keep lower geometry**.

Click **Apply**.

As a result, three plane bodies (Body 1, Body 2, Body 3) are obtained. This will be displayed in the Model Tree.



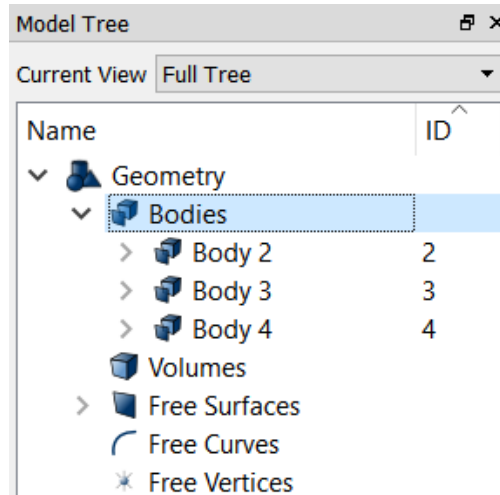

3. Delete side surfaces Body 3 and Body 4.

Select the surface removing section on Command Panel (Mode — **Geometry**, Entity — **Surface**, Action — **Delete**). Enter numbers 2 3 in the window **Surface ID(s)**.

Click **Apply**.

As a result, only the lateral cylindrical shell of 2 m radius and 2 m high will remain of the initial volume.

4. Leave a quarter of a shell (symmetry of the problem).

Select volume geometry generation section on Command Panel (Mode — **Geometry**, Entity — **Surface**, Action — **Webcut**). Select **Coordinate Plane** in the list of possible webcut types. Set the following parameters:

- Surface ID(s): 2 (*the surface to be webcut*);
- Webcut with: YZ Plane;
- Offset value: 0;
- Imprint.

Click **Apply**.

Do the same for the ZX Plane:

- Volume ID(s): 2 (*the volume to be webcut*);
- Webcut with: ZX Plane;
- Offset value: 0;
- Imprint.

Click **Apply**.

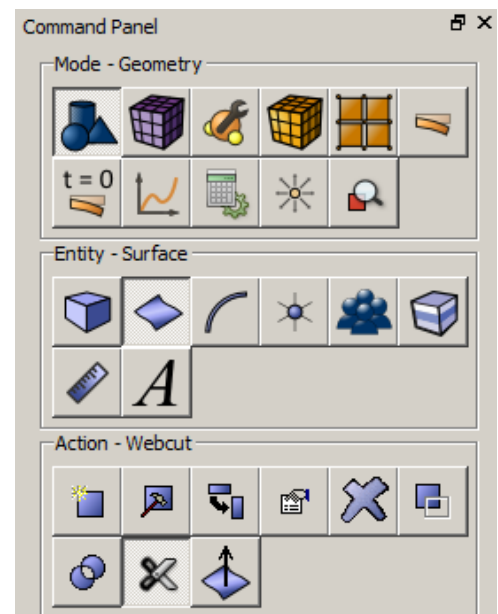

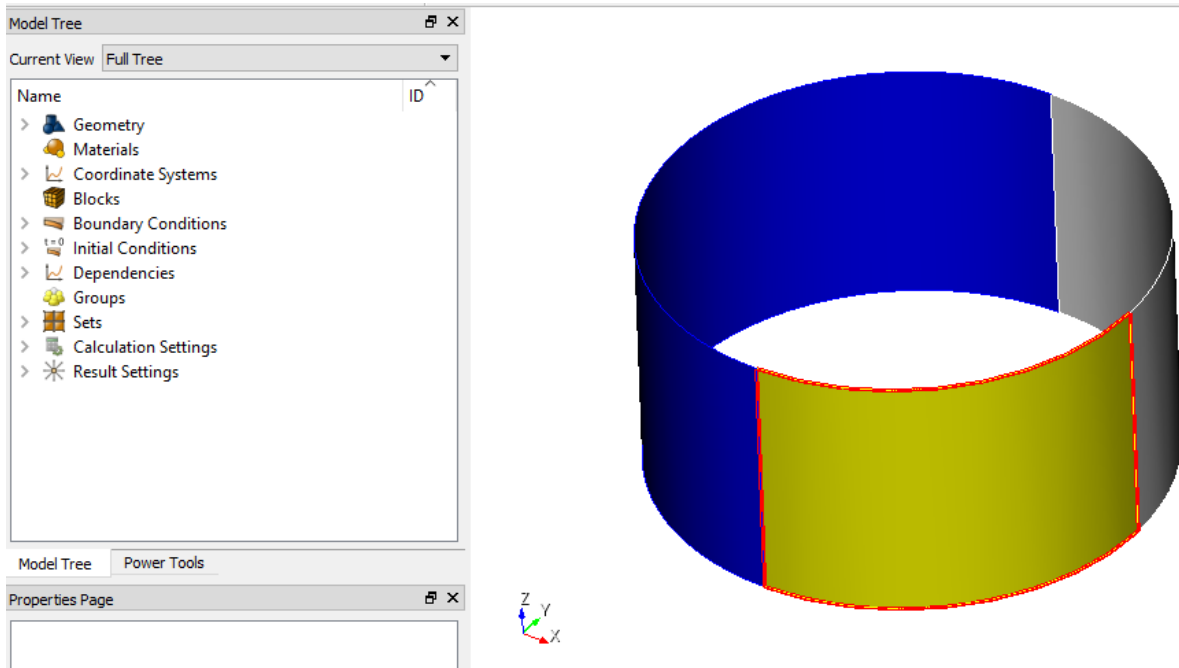

As a result, the original volume in the Model Tree is split into three (Body 2, Body 5 and Body 6).

Delete the bodies 2 and 5. To do this, select these bodies in the Model Tree holding down the Ctrl key and click **Delete** in contextual menu. As a result, a quarter of the original shell is left (Body 6):

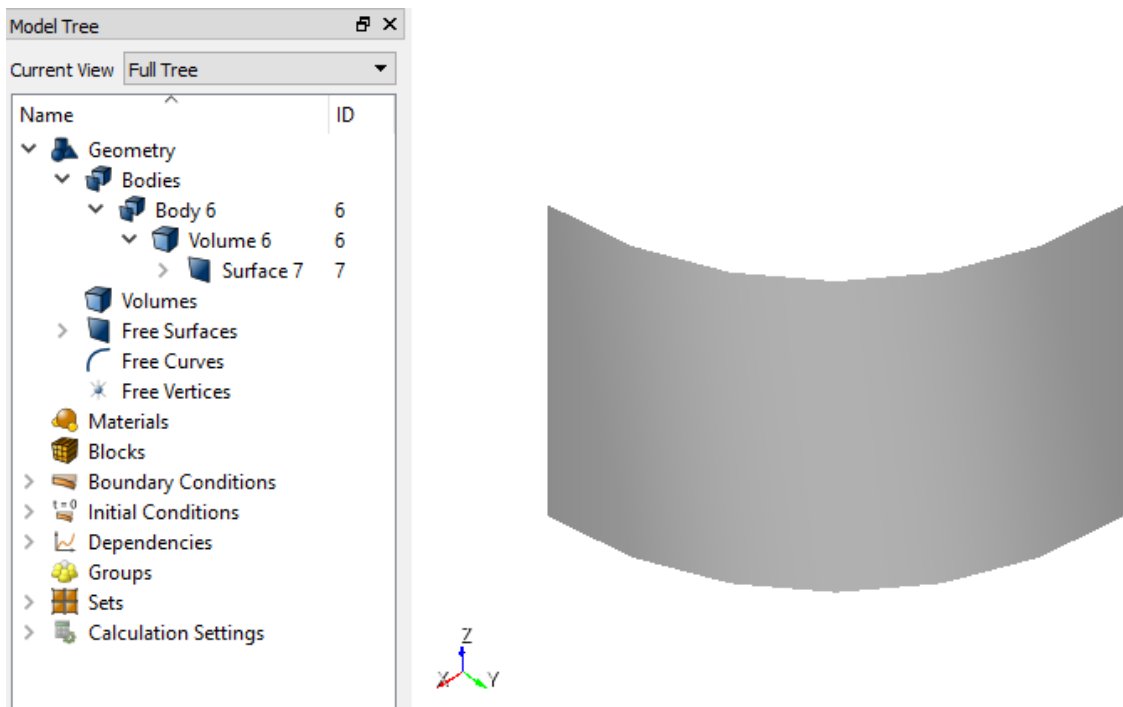

Meshing

1. Create a quadrangular mesh.

Select meshing on plane section on Command Panel (Mode — **Mesh**, Entity — **Surface**, Action — **Intervals**). Specify the parameters of mesh refinement:

- Select surfaces: 7;
- The way of meshing: Approximate Size;
- Approximate Size: 0.125.

Click **Apply Size**.

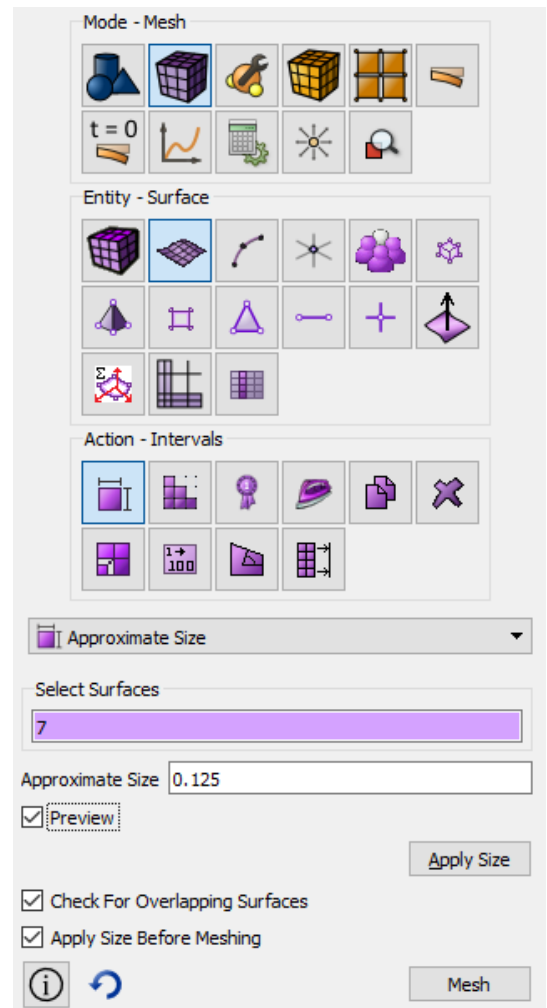

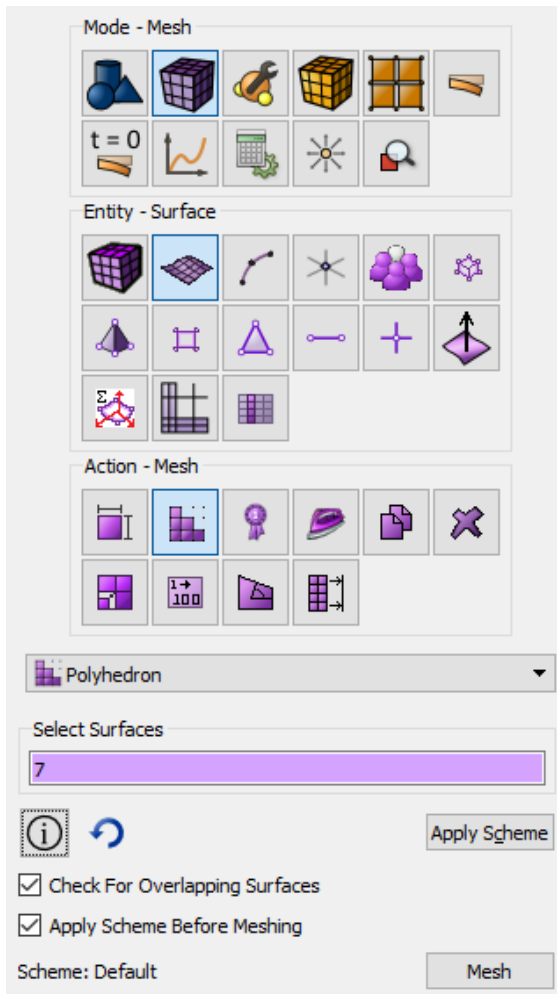

2. Select meshing on plane section on Command Panel (Mode — **Mesh**, Entity — **Surface**, Action —**Mesh**). Select meshing scheme:

- Select surfaces: 7;
- Select meshing scheme: Polyhedron;

Click **Apply Scheme**.

Click **Mesh**.

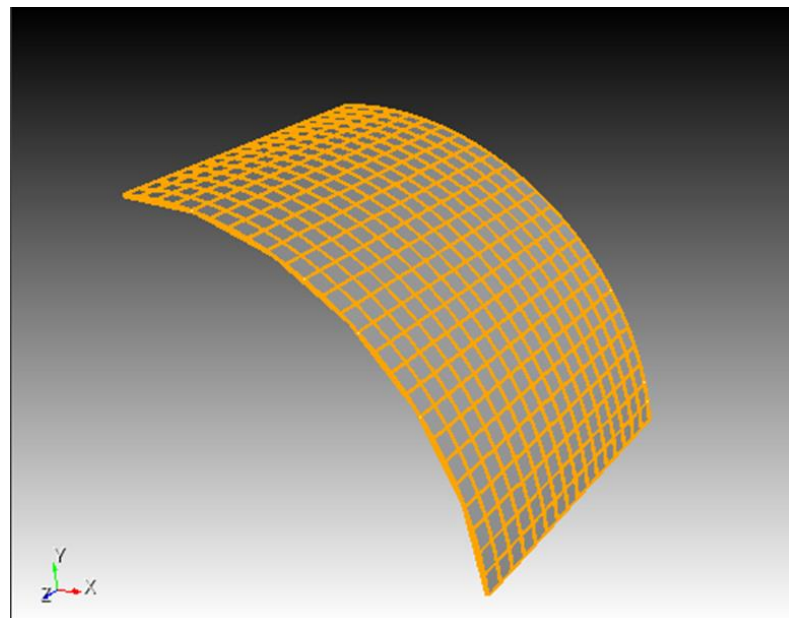

Setting boundary conditions

1. Fix the line AB on the conditions of symmetry.

Select Mode — **Boundary Conditions**, Entity — **Displacement**, Action — **Create** on Command Panel. Set the following parameters:

- System Assigned ID;
- Entity List: Curve;
- Entities ID(s): 5 (or click on the top line on a quarter of the shell);
- Degrees of Freedom: X-Translation Disp, Y-Rotation Disp, Z-Rotation Disp;
- DOF Value: 0.

Click **Apply**.

2. Fix the line CD of the conditions of symmetry.

Select Mode — **Boundary Conditions**, Entity — **Displacement**, Action — **Create** on Command Panel. Set the following parameters:

- System Assigned ID;
- Entity List: Curve;
- Entities ID(s): 16 (or click on the lower line on a quarter of the shell);
- Degrees of Freedom: Y-Translation Disp, X-Rotation Disp, Z-Rotation Disp;
- DOF Value: 0.

Click **Apply**.

3. Apply pressure to the entire surface of the shell.

Select Mode — **Boundary Conditions**, Entity — **Pressure**, Action — **Create** on Command Panel. Set the following parameters:

- System Assigned ID;
- Entity List: Surface;
- Entities ID(s): 7 (or click on the surface of the shell);
- Magnitude Value: 1000.

Click **Apply**.

Setting material and element type

1. Create the material.

Mode - Boundary Conditions

Entity - Displacement

Action - Create

ID/Name

New ID

Name

System Assigned ID

Entity List

Nodeset Volume Surface Curve

Hex Tet Face Vertex

Tri Edge Node

Entity ID(s) 5

Degrees Of Freedom

All

X-Translation Disp X-Rotation Disp

Y-Translation Disp Y-Rotation Disp

Z-Translation Disp Z-Rotation Disp

DOF Value 0

Specify Combination:

Overwrite Average

Smallest Largest

Select setting the material properties section on Command Panel (Mode — **Material**, Entity — **Materials management**).

In the Materials Management window that opens, in the second column, click on the caption Enter the name of the material and write "Material 1". Press the ENTER key.

In the left column, select Elasticity - Hooke Material. Select with the mouse the characteristic Young's modulus. Hold down the left mouse button and drag the label to Material Properties. Double-click in the Value field next to Young's modulus and enter the number $2e+11$. Similarly, from the Hooke Material section add the Poisson Ratio 0.3.

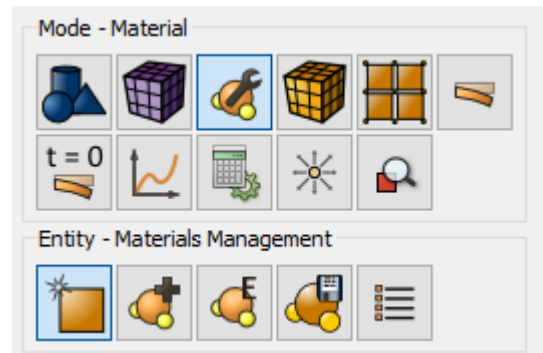

Click **Apply**.

Materials management ? ×

Material	ID	Imported material
Material 1	1	Steel
<i>Enter the name of the material</i>		Steel GOST 4543-71 (Russia)
		Rubber
		Kevlar
		Titanium
		Soil

Material properties	Value
Material 1	
Hook Material	
Young's modulus	$2e+11$
Poisson ratio	0.3

Apply

2. Create a block of one type of the material.

Select setting the material properties section on Command Panel (Mode — **Blocks**, Entity — **Block**, Action — **Add**). Set the following parameters:

- Block ID: 1;
- Entity list: **Surface**;
- Entity ID(s): 7 (or by the command *all*).

Click **Apply**.

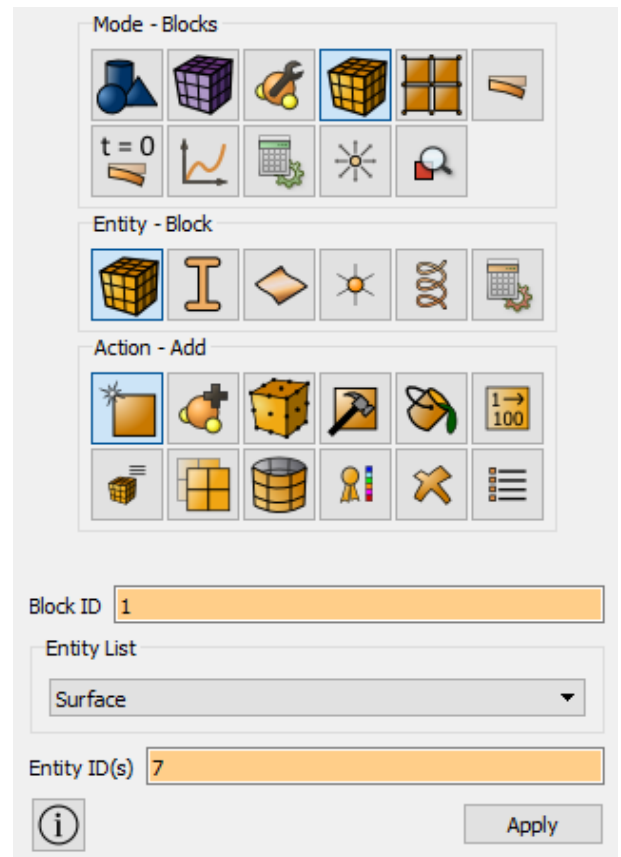

3. Assign the material to the block.

Select setting the material properties section on Command Panel (Mode — **Blocks**, Entity — **Block**, Action — **Set material**). Set the following parameters:

- Block ID(s): 1;
- Select the previously created material in the list: Material 1.

Click **Apply**.

4. Assign the element type.

Select setting the material properties section on Command Panel (Mode — **Blocks**, Entity — **Block**, Action — **Element Types**). Set the following parameters:

- Block ID(s): 1;
- Category: **Shell**;
- Order: 1.

Click **Apply**.

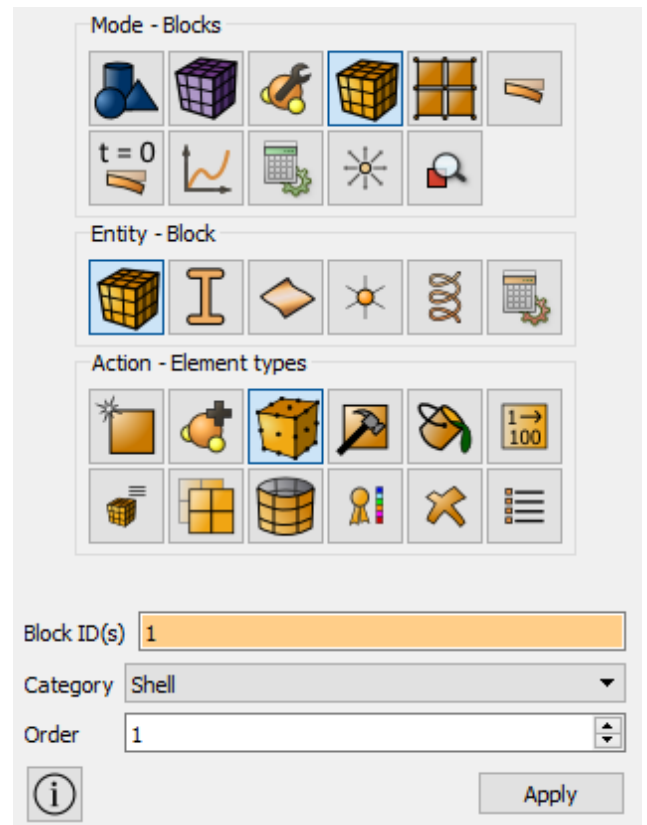

Setting shell thickness

1. Set the shell thickness.

Select setting the material properties section on Command Panel (Mode — **Blocks**, Entity — **Block**, Action — **Shell properties**). Set the following parameters:

- Block ID: 1;
- Thickness: 0.02;
- Eccentricity: 0.5;

Click **Apply**.

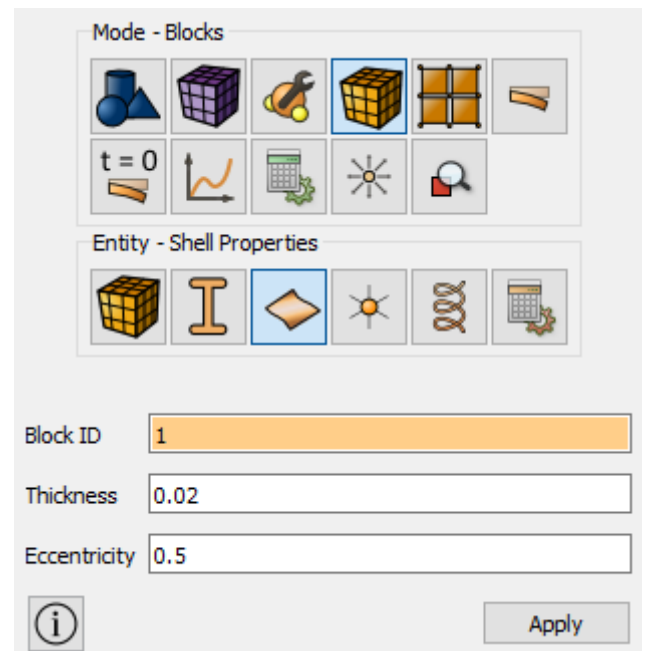

Starting calculation

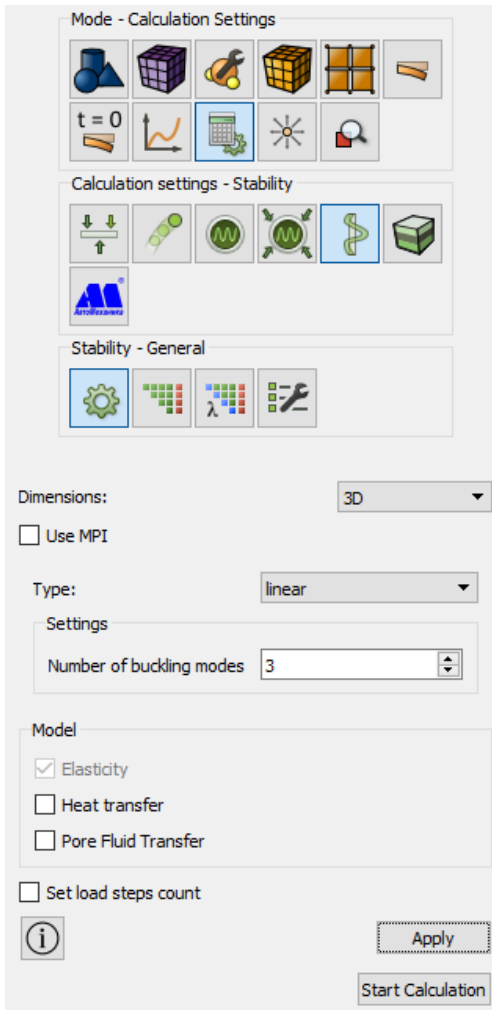

1. Set the type of the problem to be solved.

Select calculation setting section on Command Panel (Mode — **Calculation settings**, Calculation settings — **Stability**, Stability — **General**). Select 3 in the field **Number of buckling modes**. Leave other parameters by default. Click **Apply**. Click **Start calculation**.

In a pop-up window select a folder to save the result and enter the file name.

If the calculation is finished successfully, you will see a message in the Console: "Calculation finished successfully at <date> <time>".

Results analysis

1. Compare the obtained results.

The first three critical values are displayed in Command Line.

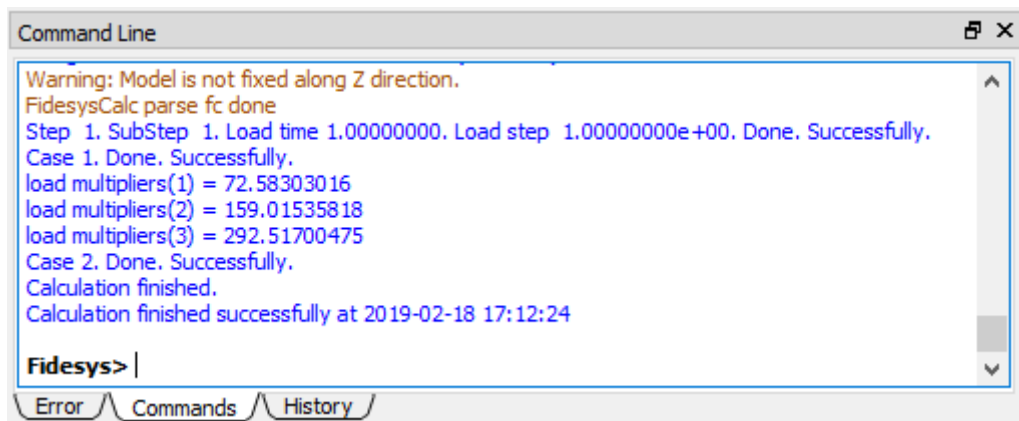

Compare the obtained results with those in the table:

Nº	Theor. value	FIDESYS
----	--------------	---------

1	72.260	72.5865	0.45%
2	164.835	159.28	3.37%
3	293.040	292.571	0.16%

2. Open the file with the results. You can do this in one of the three ways.

- Click Ctrl+E.
- Select **Calculation** → **Open Results** in the Main Menu. Click **Open last result**.
- Select **Results** on Command Panel (Mode — Results). Click **Open Results**.

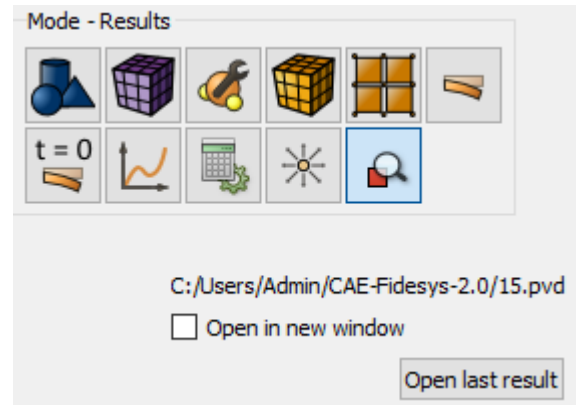

3. In a pop-up **Fidesys Viewer** window select a filter **Warp By Vector**.



4. In a pop-up filter **Warp By Vector** in the tab **Properties**, set the following parameters:

- **Vectors:** Mode 1 displacement
- **Scale Factor:** 0.1

5. Display Mode 1 displacement

In **Fidesys Viewer** window set the following parameters on Toolbar:



Make sure that the first required critical value is displayed in the window **Critical value**.

6. View results

As a result, the deformed body is displayed at the picture. To see the original model, click  near the model in the Model Tree. The picture below shows the deformed (solid grey filling) and the original model (with the distribution field Displacements for Mode 1).

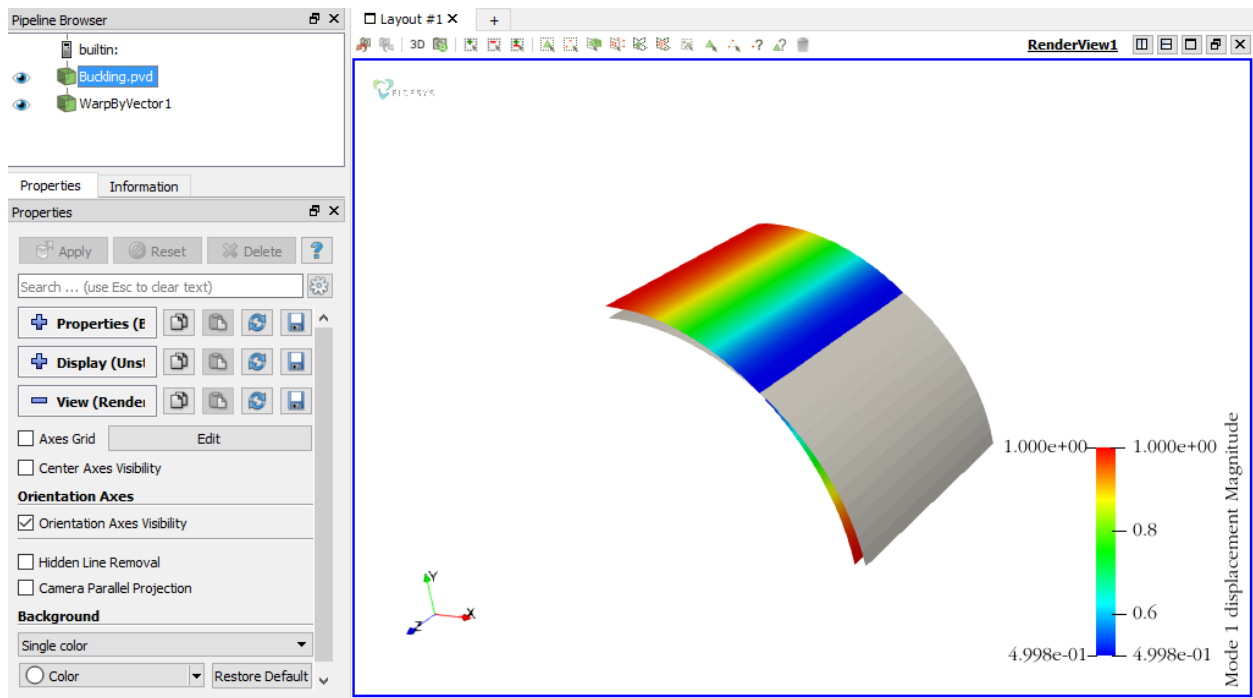

7. Select the filter **Warp By Vector** to do this. Set the following field value in the tab **Properties**:

- **Vectors:** Mode 2 displacement
- **Scale Factor:** 0.1

8. Display Mode 2 displacement.

In **Fidesys Viewer** window set the following parameters on Toolbar:

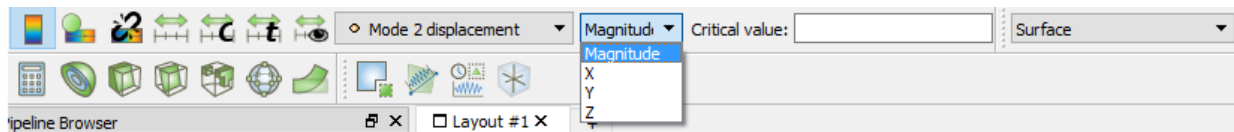

Make sure that the second required critical value is displayed in the window **Critical value**.

9. View results

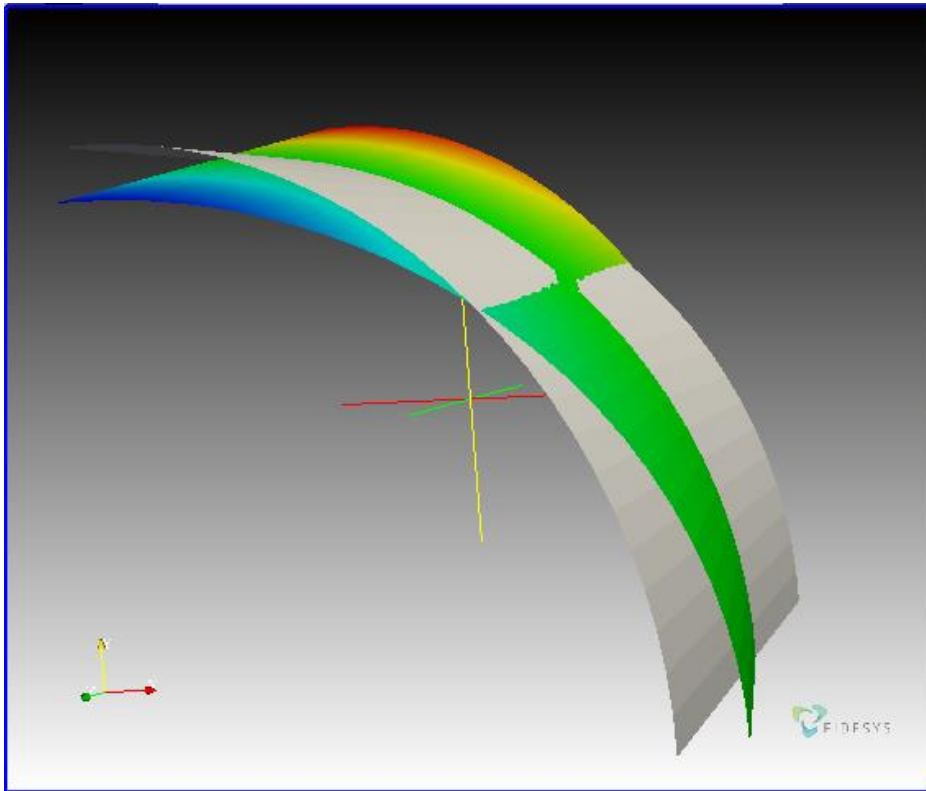

Display Mode 3 displacement in the same way, make sure that the third required critical value is displayed in the window **Critical value**.

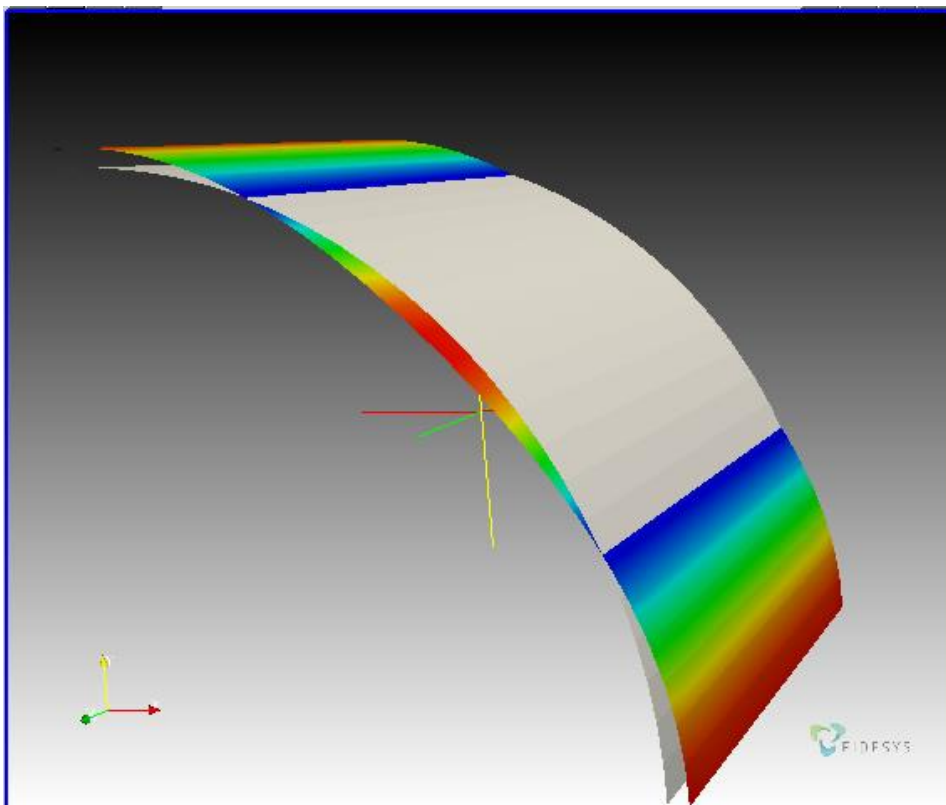

10. Display the 3D-view of the model (shell with thickness).

To do this, click on the name of the source file in the Model Tree. After this click 3D-view button in the default string.

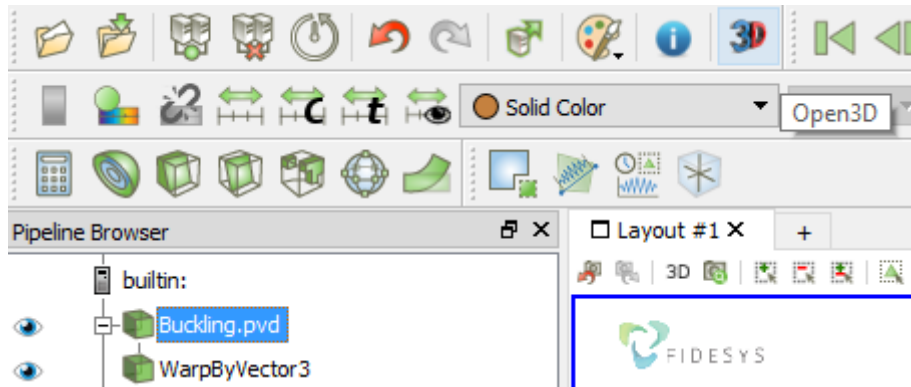

The file* _3D.pvd with a 3D-image of the shell must be opened and you will be able to apply various filters to it and to view its deformed view.

Choose the new file example_3D.pvd in the Model Tree and display Filters **Warp by Vector** for it with the following fields values:

- **Vectors:** Mode 1 displacement
- **Scale Factor:** 0.1

On the Toolbar, set once again the following parameters for the deformed type:

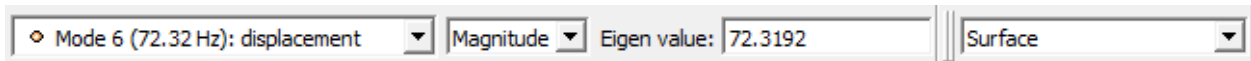

The first buckling mode will be displayed on the screen but the shell will be enveloped with thickness.

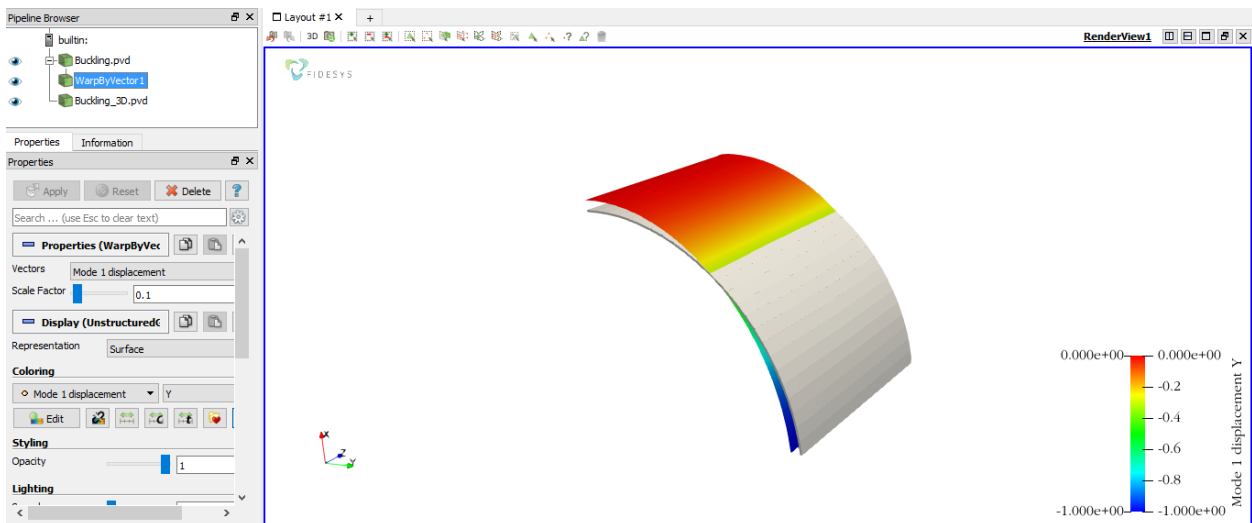



To apply all of the filters changes automatically, click **Apply changes to parameters automatically** on Command Panel.

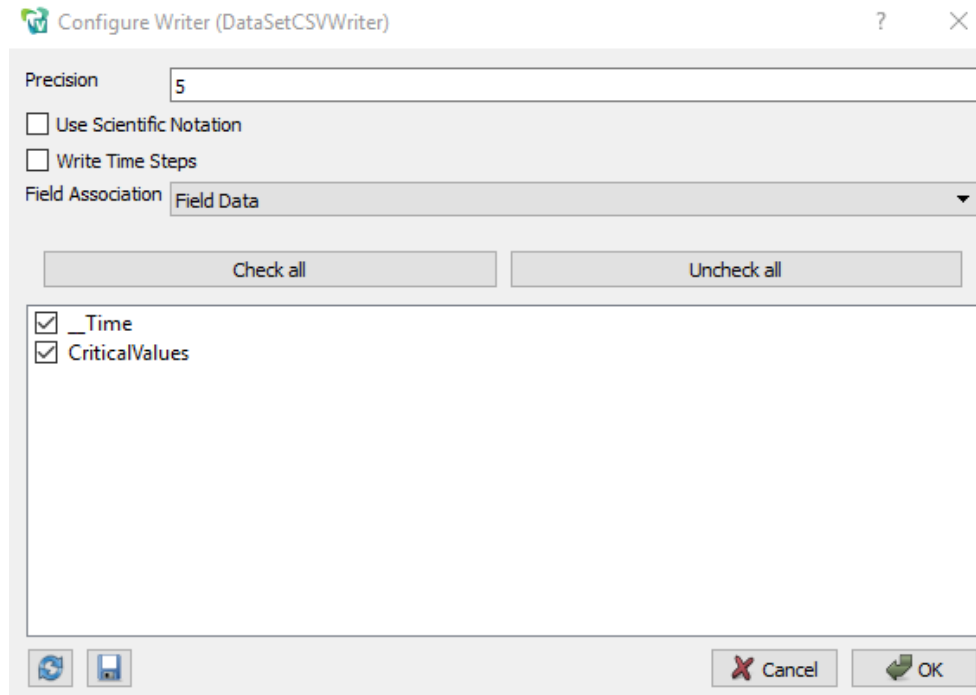

11. Download numerical data.

Select **File** → **Save Data** in the Main Menu or click **Ctrl+S**. Enter the file name (*.csv format), leave it by default. Click **OK**. In the pop-up window select:

- **Field Association:** Field Data

The saved file is an ordinary table of numerical data which can be opened in any text editor.

Using Console Interface

For geometry generation, meshing, setting boundary conditions and materials you can use Console Interface. The following program code allows performing the steps of the above-described guide, you only need to **manually specify the full path and name of the file to be saved**.

```
reset
set node constraint on
create Cylinder height 2 radius 2
delete volume 1 keep_lower_geometry
delete Surface 3 2
webcut body 2 with plane xplane offset 0 imprint preview
webcut body 2 with plane xplane offset 0 imprint
webcut body 2 with plane yplane offset 0 imprint preview
webcut body 2 with plane yplane offset 0 imprint
delete Surface 5 6
surface 7 size 0.125
surface 7 scheme Polyhedron
mesh surface 7
create displacement on curve 16 dof 2 dof 4 dof 6 fix 0
create displacement on curve 5 dof 1 dof 5 dof 6 fix 0
create pressure on surface 7 magnitude 1000
create material 1
modify material 1 name 'Material 1'
```



```
modify material 1 set property 'POISSON' value 0.3
modify material 1 set property 'MODULUS' value 2e+11
set duplicate block elements off
block 1 surface 7
block 1 material 'Material 1'
block 1 element shell order 1
undo group begin
block 1 attribute count 2
block 1 attribute index 1 value 0.02
block 1 attribute index 2 value 0.5
undo group end
analysis type stability elasticity dim3
calculation start path "D:/Fidesys/example.pvd"
```



It is also possible to run the file *Example_6_Stability_Shell.jou*, by selecting Journal Editor on Toolbar. In a pop-up window of the main menu select **File** → **Open** and open the necessary journal file.

Modal analysis (3D)

NAFEMS Selected Benchmarks for Natural Frequency Analysis "Simply Supported "Solid" Square Plate", Test No FV52.

The problem of modal analysis of a square plate is being solved.

The picture represents a geometric model of the problem and a mesh:

The size of the plate is 10 m x 10 m x 1 m. Displacements along z-axis are constrained for the edges of the plate bottom side. The material parameters are $E = 200 \text{ hPa}$, $\nu = 0.3$, $\rho = 8000 \text{ kg/m}^3$.

Eigenmodes from 4 to 10 are to be compared.

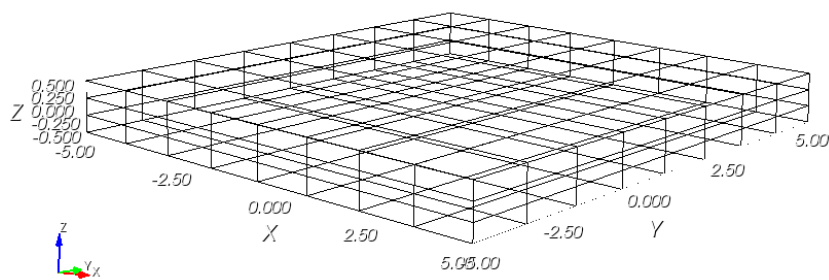

Geometry creation

1. Create the plate.

Select volume geometry generation section on Command Panel (Mode — **Geometry**, Entity — **Volume**, Action — **Create**). Select **Brick** in the list of geometric elements. Set the brick dimensions:

- X (width): 10
- Y (height): 10
- Z (depth): 1

Click **Apply**.

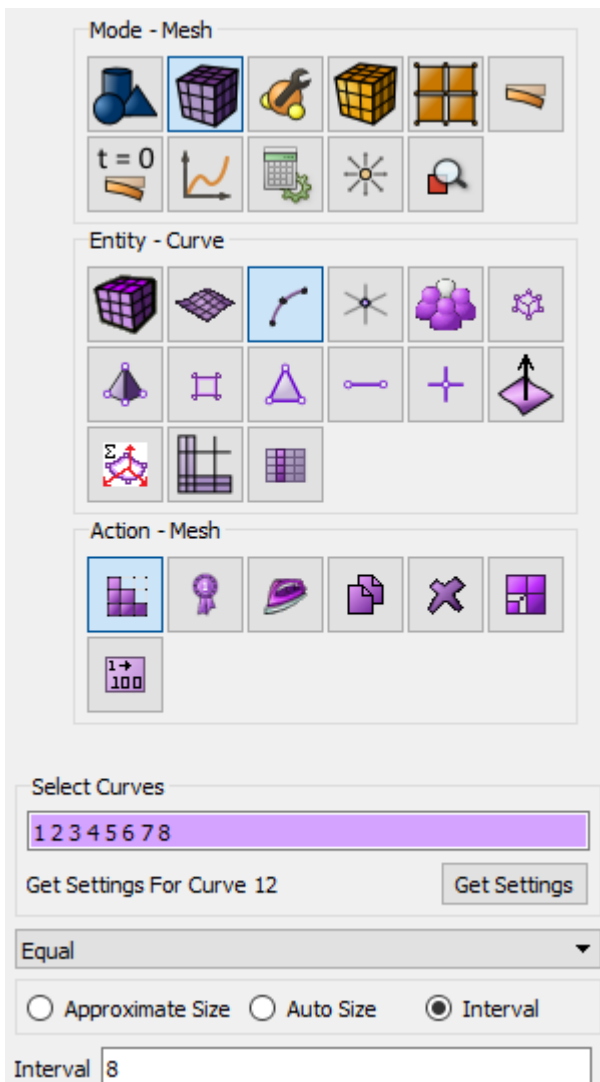
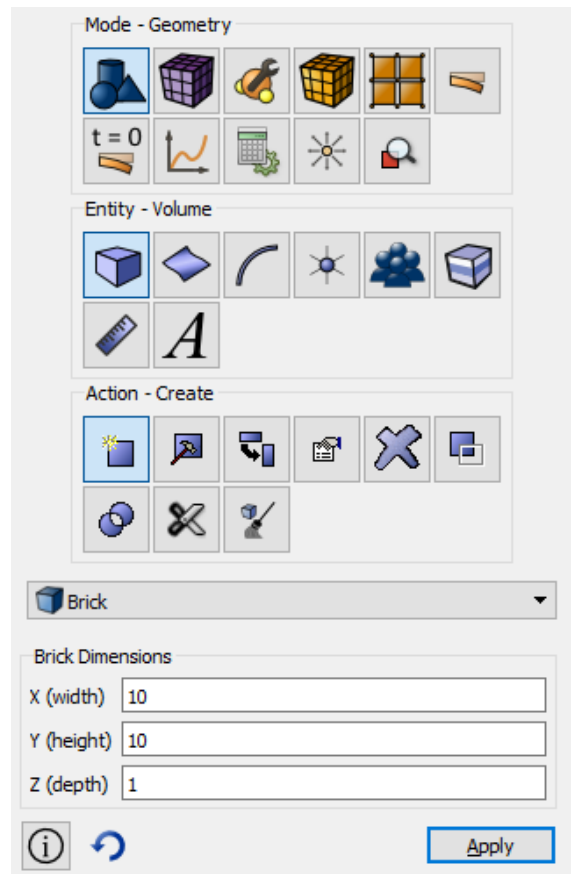

Meshing

A mesh of 8*8*3 linear hexahedral elements is to be generated (as shown at the picture with the problem setting).

1. Select meshing on curves section on Command Panel (Mode — **Mesh**, Entity — **Curve**, Action — **Mesh**). Specify the parameters of mesh refinement:

- Select Curves: 1 2 3 4 5 6 7 8 (*using space after each of them*);
- Select the way of meshing: Equal;
- Select splitting settings: Interval;
- Interval: 8 (see the figure)

Click **Apply Size**.

2. Select meshing on curves section on Command Panel (Mode — **Mesh**, Entity — **Curve**, Action — **Mesh**). Specify the parameters of mesh refinement:

- Select Curves: 9 10 11 12 (*using space after each of them*);
- Select the way of meshing: Equal;
- Select splitting settings: Interval;

- Interval: 3.

Click **Apply Size**.

Select volume mesh generation section on Command Panel (Mode — **Mesh**, Entity — **Volume**, Action — **Mesh**).

- Select Volumes: 1 (or by the command **all**)
- Select Meshing Scheme: Automatically Calculate

Click **Apply Scheme**.

Click **Mesh**.

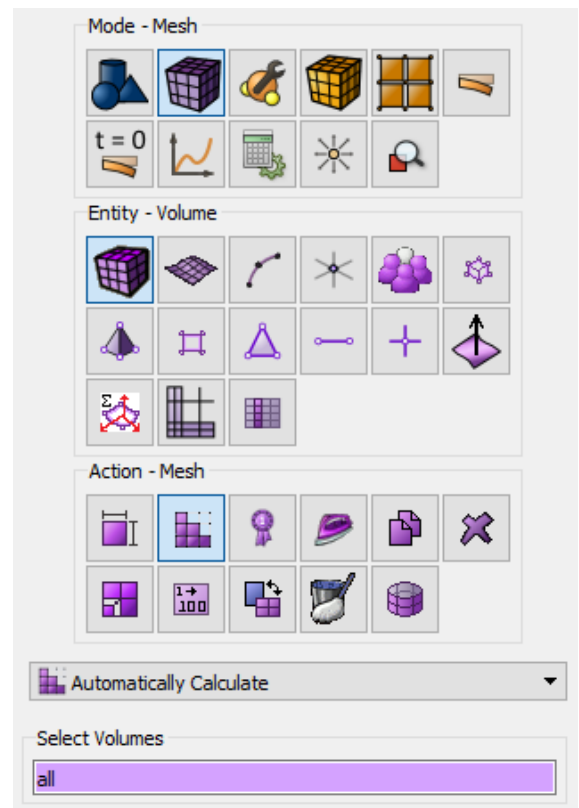

Setting boundary conditions

1. Fix the bottom side edges along Z.

Select Mode — **Boundary Conditions**, Entity — **Displacement**, Action — **Create** on Command Panel. Set the following parameters:

- System Assigned ID
- Entity List: Curve
- Entity ID(s): 5 6 7 8 (using space after each of them)
- Degrees of Freedom: Z-Translation
- DOF Value: 0

Click **Apply**.



Setting material and element type

1. Create the material.

Select setting the material properties section on Command Panel (Mode—**Material**, Entity—**Materials management**).

In the Materials Management window that opens, in the second column, click on the caption Enter the name of the material and write "Material 1". Press the ENTER key.

In the left column, select Elasticity - Hooke Material. Select with the mouse the characteristic Young's modulus. Hold down the left mouse button and drag the label to Material Properties. Double-click in the Value field next to Young's modulus and enter the number 2e11. Similarly, from the Hooke Material section add the Poisson Ratio 0.3. Density: 8000

Click **Apply**.

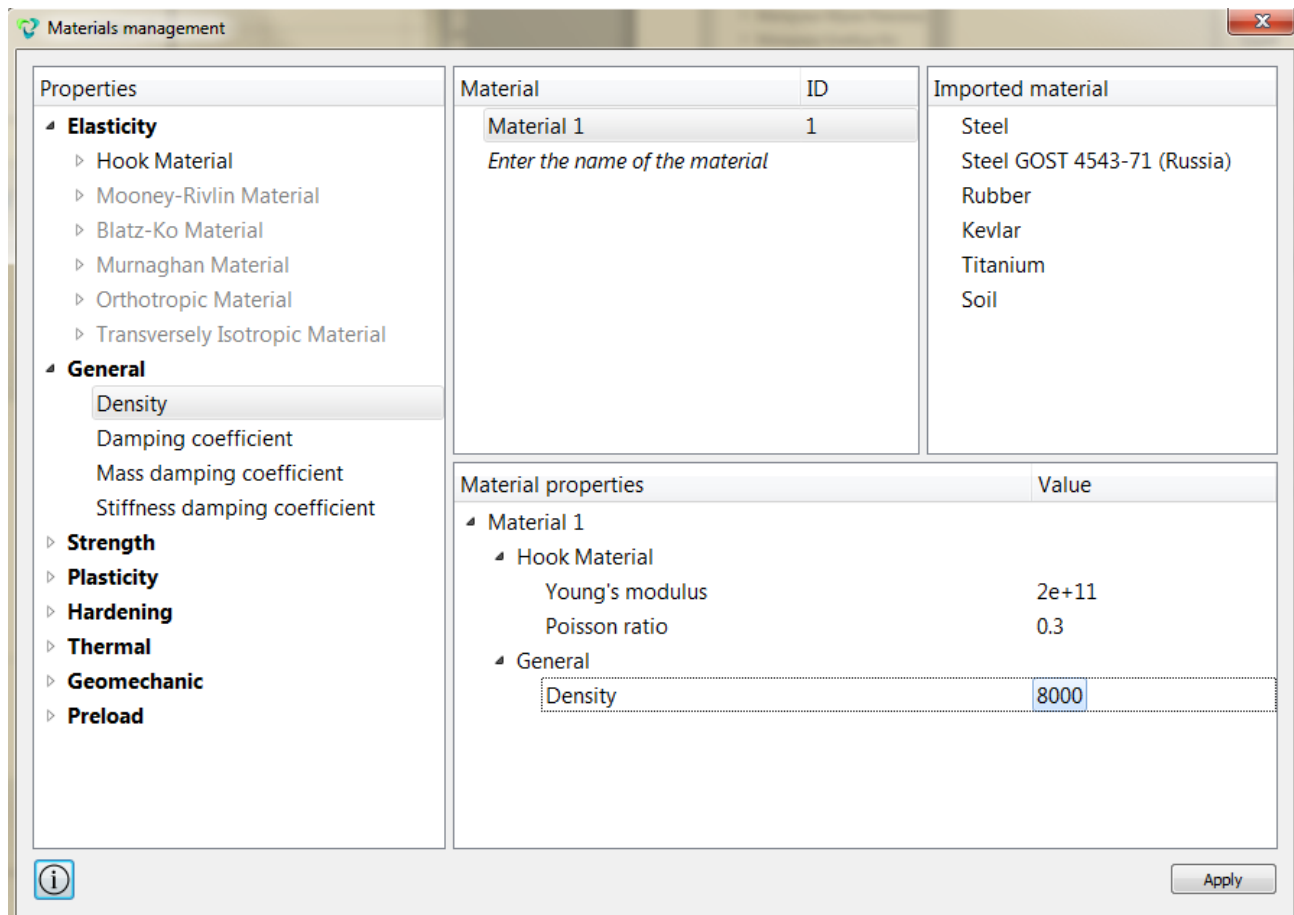
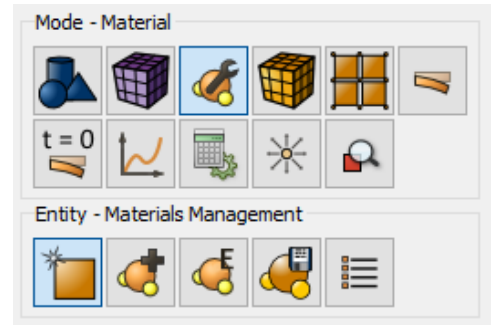

2. Create a block of one type of the material.

Select setting the material properties section on Command Panel (Mode — **Blocks**, Entity — **Block**, Action — **Add**). Set the following parameters:

- Block ID: 1;
- Entity list: Volume;
- ID: 1 (or by the command *all*).

Click **Apply**.

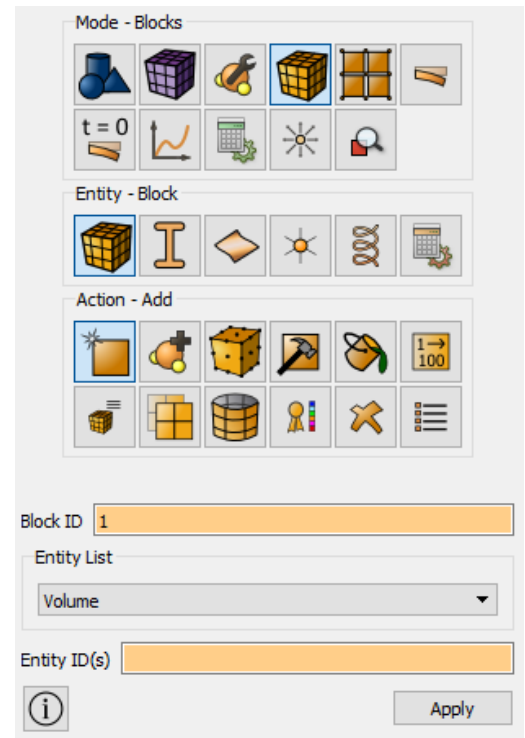

3. Assign the material to the block.

Select setting the material properties section on Command Panel (Mode — **Blocks**, Entity — **Block**, Action — **Set material**). Set the following parameters:

- Block ID(s): 1;
- Select the previously created material in the list: Material 1.

Click **Apply**.

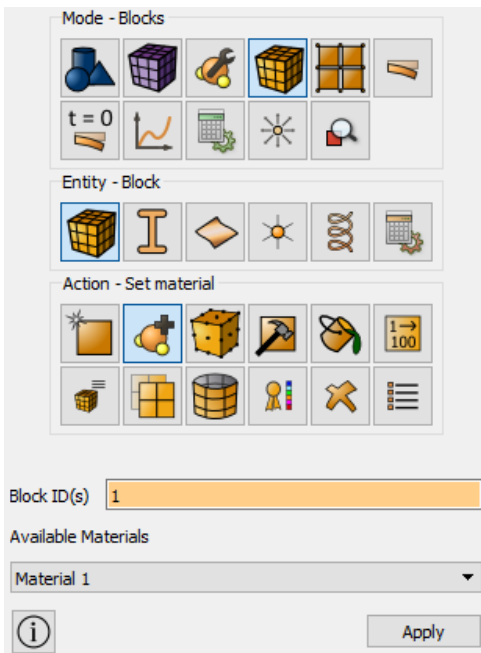

4. Assign the element type.

Select setting the material properties section on Command Panel (Mode — **Blocks**, Entity — **Block**, Action — **Element Types**). Select in the list of possible operations. Set the following parameters:

- Block ID(s): 1;
- Select: Volumes;
- Order: 1

Click **Apply**.

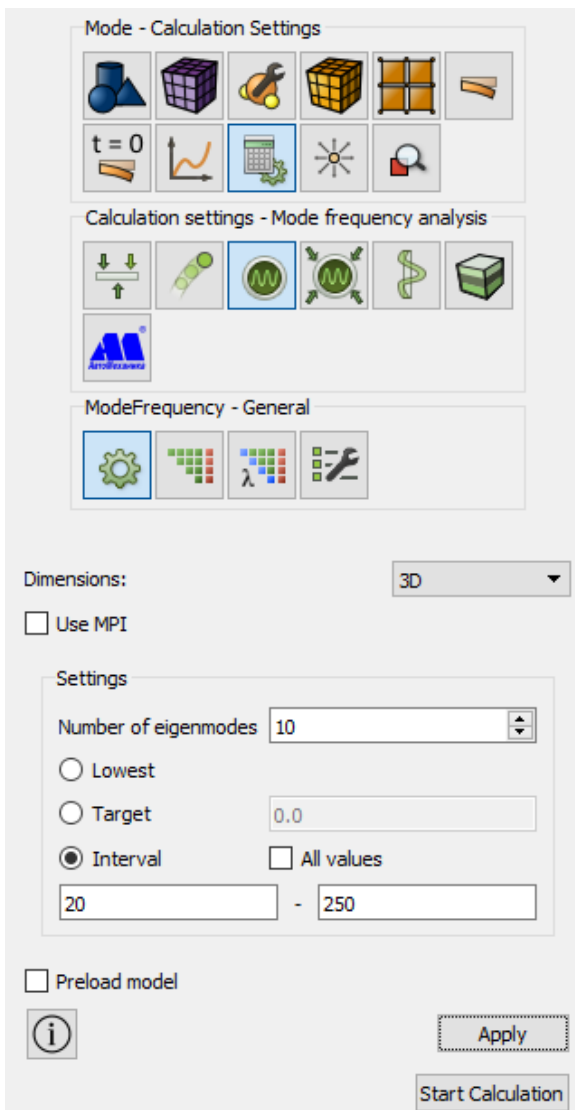
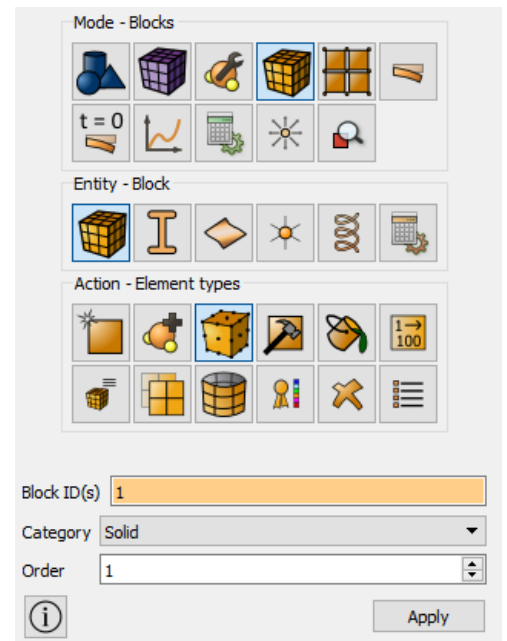

Starting calculation

1. Set the type of the problem to be solved.

Select calculation setting section on Command Panel (Mode — **Calculation settings**, Calculation settings — **Mode frequency analysis**, ModeFrequency — **General**). Specify the following settings:

- Interval: 20 – 250.

Click **Apply**.

Click **Start Calculation**.

2. In a pop-up window select a folder to save the result and enter the file name.

3. If the calculation is finished successfully, you will see a message in the Console: "*Calculation finished successfully at <date> <time>*" as well as the required eigen values and frequencies.

Results analysis

1. Compare the obtained results to those in the given table.

№	NAFEMS	FIDESYS	
		Value, Hz	Error
4	51.65	51.68	0.1%
5	132.73	132.75	0.0%
6	132.73	132.75	0.0%
7	194.37	194.38	0.0%
8	197.18	197.19	0.0%
9	210.55	210.55	0.0%
10	210.55	210.55	0.0%

2. Open the file with the results. You can do this in one of the three ways.

- Click Ctrl+E.

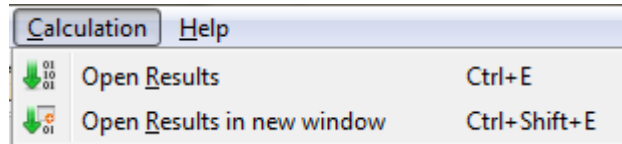

- Select **Calculation** → **Open Results** in the Main Menu. Click **Open last result**.
- Select **Results** on Command Panel (Mode — **Results**). Click **Open Results**.

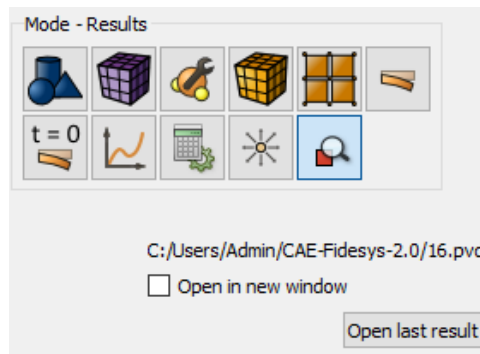

3. You can see the way the body is deformed.

Select a filter **Warp By Vector** to do this. Set the following parameters in the tab **Properties**:

- Vectors: Eigenvalue_# (*# stands for the number of the eigenvalue*)
- Scale Factor: 700

As a result, the deformed body is displayed at the picture. To see the original model, click  near it in the Model Tree. The picture below shows the deformed model at different eigenvalues.

4 eigenmode

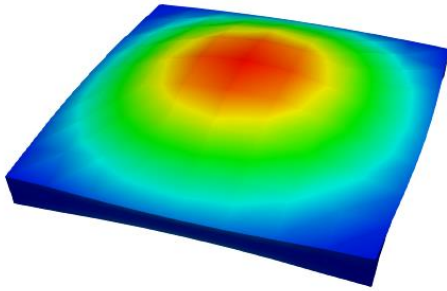

5 eigenmode

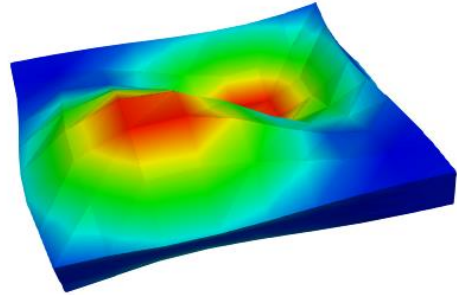

6 eigenmode

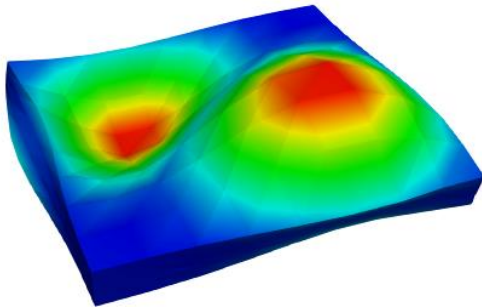

7 eigenmode

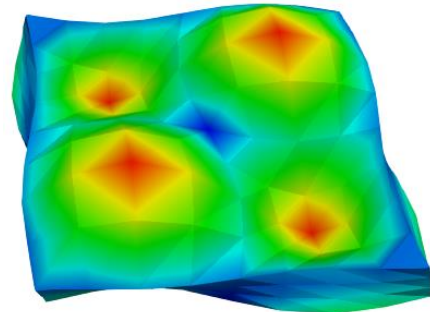

8 eigenmode

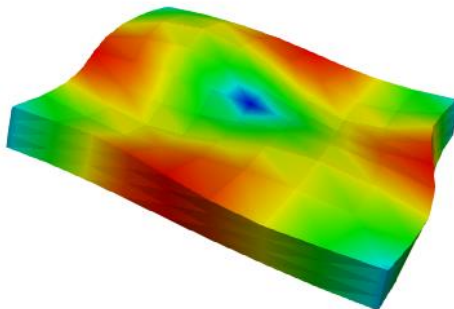

9 eigenmode

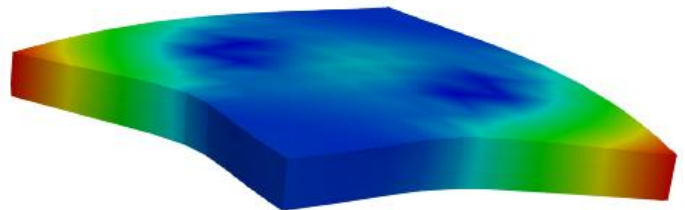

10 eigenmode

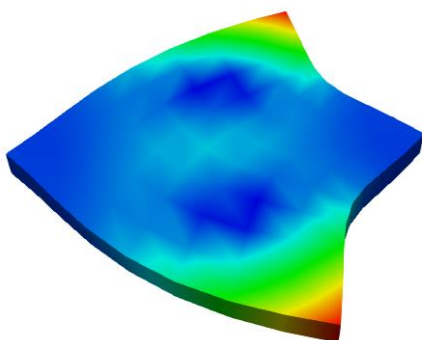

Using Console Interface

For geometry generation, meshing, setting boundary conditions and materials you can use Console Interface. The following program code allows performing the steps of the above-described guide, you only need to **manually specify the full path and name of the file to be saved**.

```
reset
set node constraint on
brick x 10 y 10 z 1
curve 1 2 3 4 5 6 7 8 interval 8
curve 1 2 3 4 5 6 7 8 scheme equal
curve 9 10 11 12 interval 3
curve 9 10 11 12 scheme equal
volume 1 scheme Auto
volume 1 scheme Auto
mesh volume 1
create displacement on curve 5 6 7 8 dof 3 fix 0
create material 1
modify material 1 name 'Material 1'
modify material 1 set property 'POISSON' value 0.3
modify material 1 set property 'MODULUS' value 2e+11
modify material 1 set property 'DENSITY' value 8000
set duplicate block elements off
block 1 volume 1
block 1 material 'Material 1'
block 1 element solid order 1
analysis type eigenfrequencies elasticity dim3
eigenvalue find 10 smallest
calculation start path "D:/Fidesys/example.pvd"
```



It is also possible to run the file *Example_7_EigenValue_3D.jou*, by selecting Journal Editor on Toolbar. In a pop-up window of the main menu select **File** → **Open** and open the necessary journal file .

Modal analysis (shell model)

NAFEMS-Glasgow, BENCHMARK newsletter, Report No. E1261/Roo2, "Free Vibrations of a Simply-supported Thin Square Plate", February 1989, p.21.

The problem of modal analysis of a square plate is being solved.

The size of the plate is 10 m x 10 m, the thickness is 0.05 m. X- and Y-Translation and Z-Rotation are constrained for all nodes of the plate. All the edges are constrained in Z-direction. The X-rotation is constrained for edges AB and CD. The Y-rotation is constrained for edges BC and AD. The material parameters are $E = 200 \text{ hPa}$, $\nu = 0.3$, $\rho = 8000 \text{ kg/m}^3$.

Eigenmodes from 1 to 8 are to be compared.

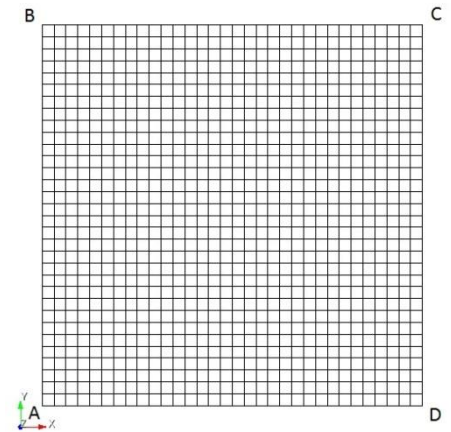

Geometry creation

1. Create the plate.

Select volume geometry generation section on Command Panel (Mode — **Geometry**, Entity — **Surface**, Action — **Create**). Select **Rectangle** in the list of geometric elements. Set the brick dimensions:

- Width: 10;
- Location: ZPlane.

Click **Apply**.

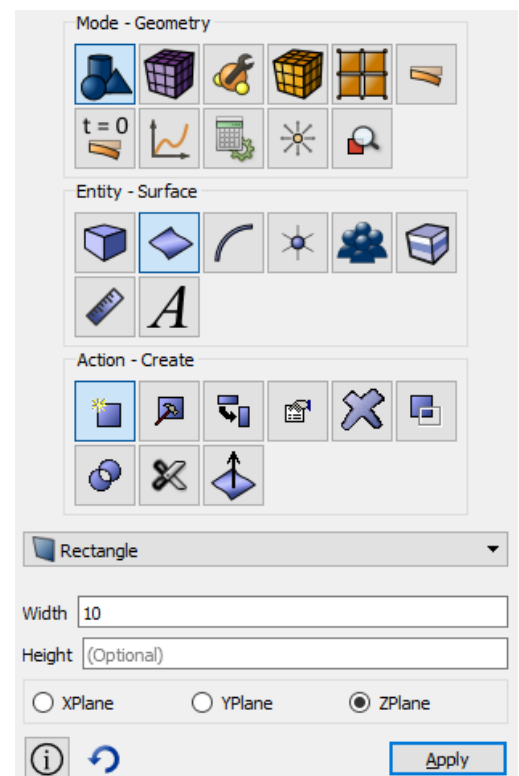

Meshing

A mesh of 32×32 linear quadrilateral elements is to be generated (as shown at the picture with the problem setting).

- Select meshing on curves section on Command Panel (Mode — **Mesh**, Entity — **Curve**, Action — **Mesh**). Specify the parameters of mesh refinement:
 - Select Curves: all;
 - Select the way of meshing: Equal;
 - Select splitting settings: Interval;
 - Interval: 32 (see the figure).

Click **Apply Size**.

Click **Mesh**.

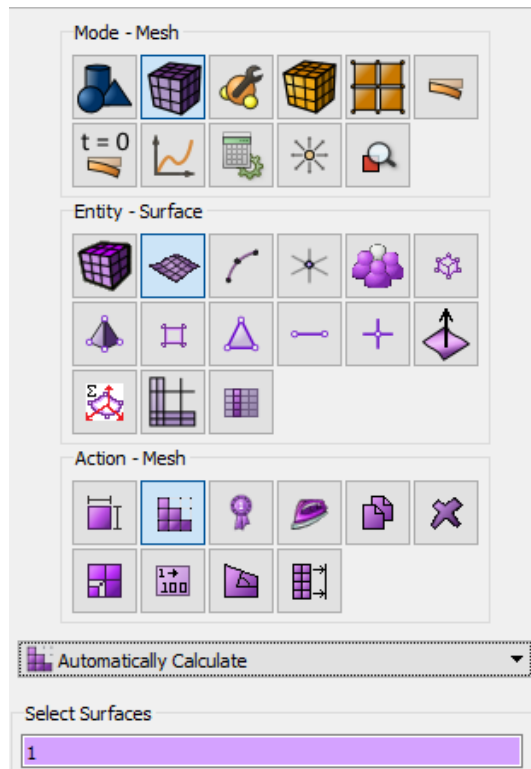
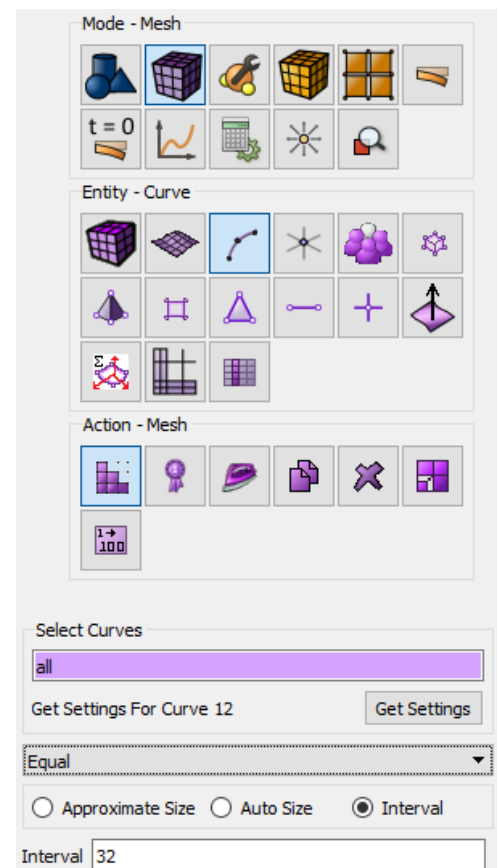

- Select surface mesh generation section on Command Panel (Mode — **Mesh**, Entity — **Surface**, Action — **Mesh**).

- Select Surfaces: 1 (or by the command *all*)
- Select Meshing Scheme: Automatically Calculate

Click **Apply Scheme**.

Click **Mesh**.

Setting boundary conditions

1. Fix the plate: X- and Y-Translations and Z-Rotations.

Select Mode — **Boundary Conditions**, Entity — **Displacement**, Action — **Create** on Command Panel. Set the following parameters:

- System Assigned ID;
- Entity List: Node;
- Entity ID(s): all;
- Degrees of Freedom: X-Translation, Y-Translation and Z-Rotation;
- DOF Value: 0.

Click **Apply**.

2. Fix all the edges at the Z-direction.

Select Mode — **Boundary Conditions**, Entity — **Displacement**, Action — **Create**. Set the following parameters:

- System Assigned ID;
- Entity List: Curves;
- Entity ID(s): all;
- Degrees of Freedom: Z-Translation;
- DOF Value: 0.

Click **Apply**.

3. Fix the edges AB and CD on X-Rotation.

Select Mode — **Boundary Conditions**, Entity — **Displacement**, Action — **Create** on Command Panel. Set the following parameters:

- System Assigned ID;
- Entity List: Curves;
- Entity ID(s): 2 4 (*using space after each of them*);
- Degrees of Freedom: X-Rotation;
- DOF Value: 0.

Click **Apply**.

4. Fix the edges BC and AD in Y-rotation.

Select Mode — **Boundary Conditions**, Entity — **Displacement**, Action — **Create** on Command Panel. Set the following parameters:

- System Assigned ID;
- Entity List: Curves;

Mode - Boundary Conditions

Entity - Displacement

Action - Create

ID/Name

New ID

Name

System Assigned ID

Entity List

Nodeset Volume Surface Curve

Hex Tet Face Vertex

Tri Edge Node

Entity ID(s) all

Degrees Of Freedom

All

X-Translation Disp X-Rotation Disp

Y-Translation Disp Y-Rotation Disp

Z-Translation Disp Z-Rotation Disp

DOF Value 0

Specify Combination

Overwrite Average

Smallest Largest

- Entity ID(s): 1 3 (*using space after each of them*);
- Degrees of Freedom: Y-Rotation;
- DOF Value: 0.

Click **Apply**.

Setting material and element type

1. Create the material.

Select setting the material properties section on Command Panel (Mode — **Material**, Entity — **Materials management**).

In the Materials Management window that opens, in the second column, click on the caption Enter the name of the material and write "Material 1". Press the ENTER key.

In the left column, select Elasticity - Hooke Material. Select with the mouse the characteristic Young's modulus. Hold down the left mouse button and drag the label to Material Properties. Double-click in the Value field next to Young's modulus and enter the number 200e9. Similarly, from the Hooke Material section add the Poisson Ratio 0.3, Density: 8000.

Click **Apply**.

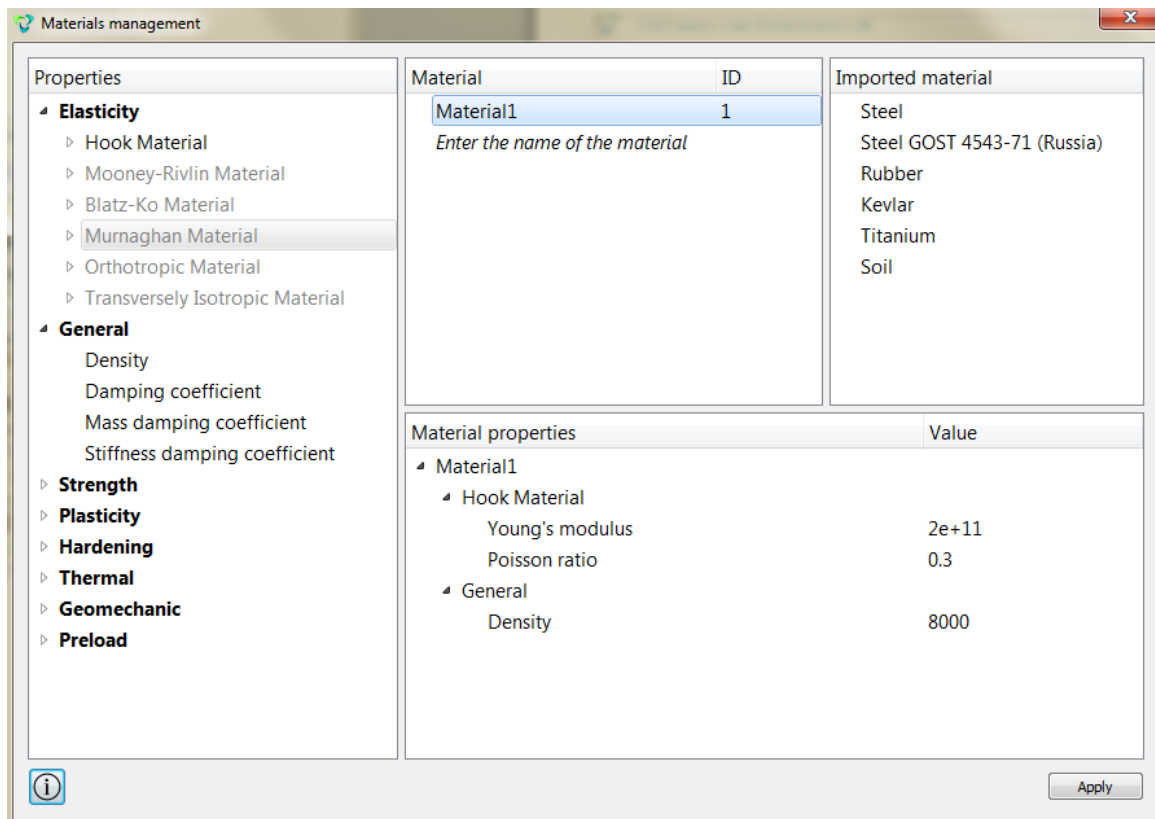
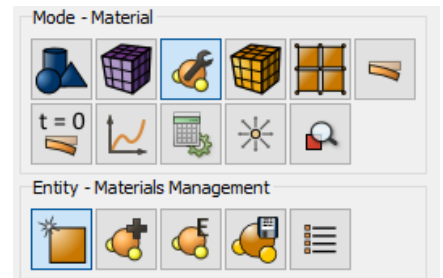

2. Create the block of one type of the material

Select setting the material properties section on Command Panel (Mode — **Blocks**, Entity — **Block**, Action — **Add**). Set the following parameters:

- Block ID: 1;
- Entity list: Surface;
- ID: 1 (or by the command *all*).

Click **Apply**.

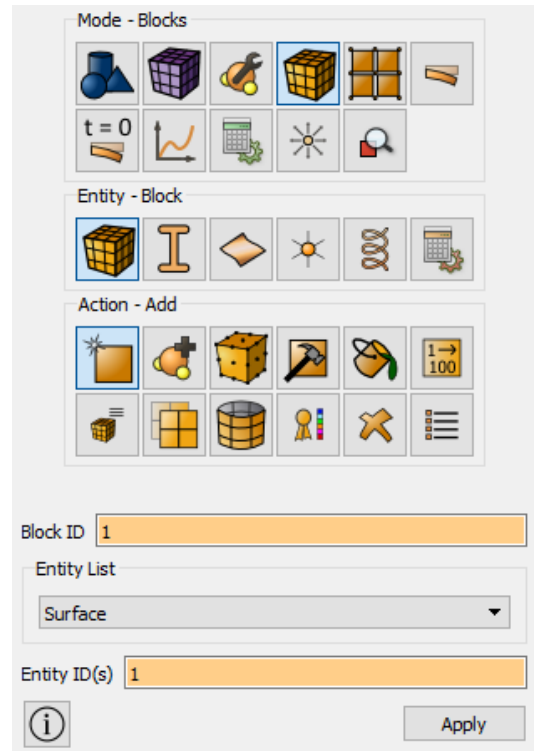
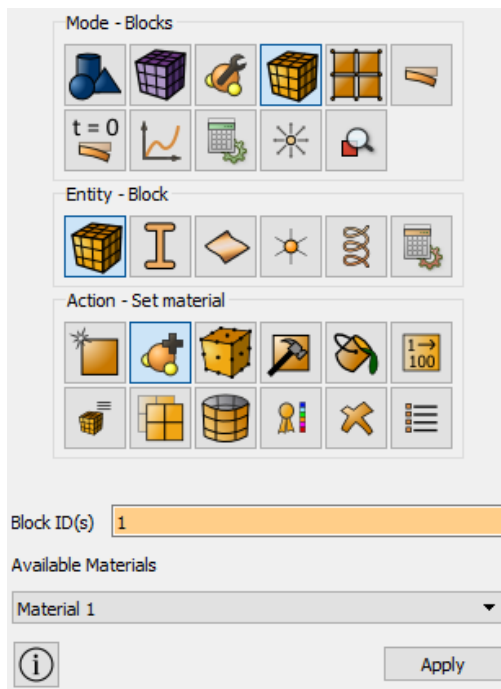

3. Assign the material to the block.

Select setting the material properties section on Command Panel (Mode — **Blocks**, Entity — **Block**, Action — **Set material**). Set the following parameters:

- Block ID(s): 1;
- Select the previously created material in the list: Material 1.

Click **Apply**.

4. Assign the element type.

Select setting the material properties section on Command Panel (Mode — **Blocks**, Entity — **Block**, Action — **Element Types**). Set the following parameters:

- Block ID(s): 1;
- Select: Surfaces;
- Order: 1.

Click **Apply**.

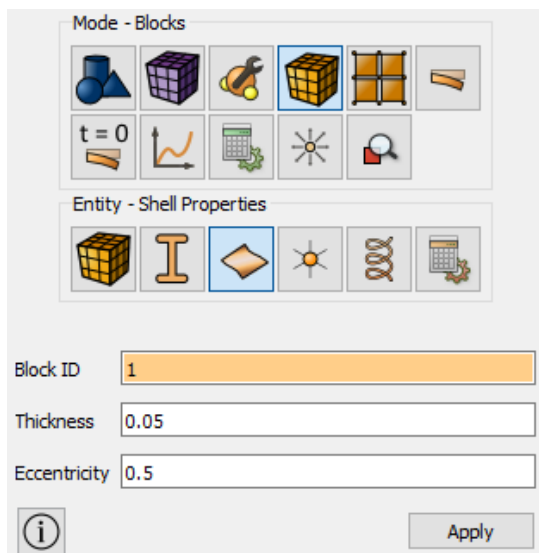
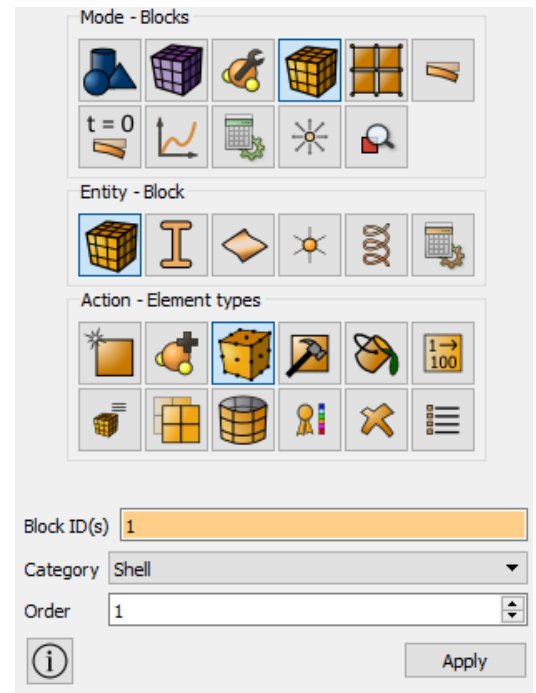

Setting shell thickness

1. Set the shell thickness.

Select setting the material properties section on Command Panel (Mode — **Blocks**, Entity — **Shell properties**). Set the following parameters:

- Block ID: 1;
- Thickness: 0.05;
- Eccentricity: 0.5;

Click **Apply**.

Starting calculation

1. Set the type of the problem to be solved.

Select calculation setting section on Command Panel (Mode — **Calculation settings**, Calculation settings — **Eigen Frequencies**, Eigen Frequencies — **General**). Set the default settings.

Click **Apply**.

Click **Start Calculation**.

2. In a pop-up window select a folder to save the result and enter the file name.
3. If the calculation is finished successfully, you will see a message in the Console: "*Calculation finished successfully at <date> <time>*" as well as the required eigenvalues and frequencies.

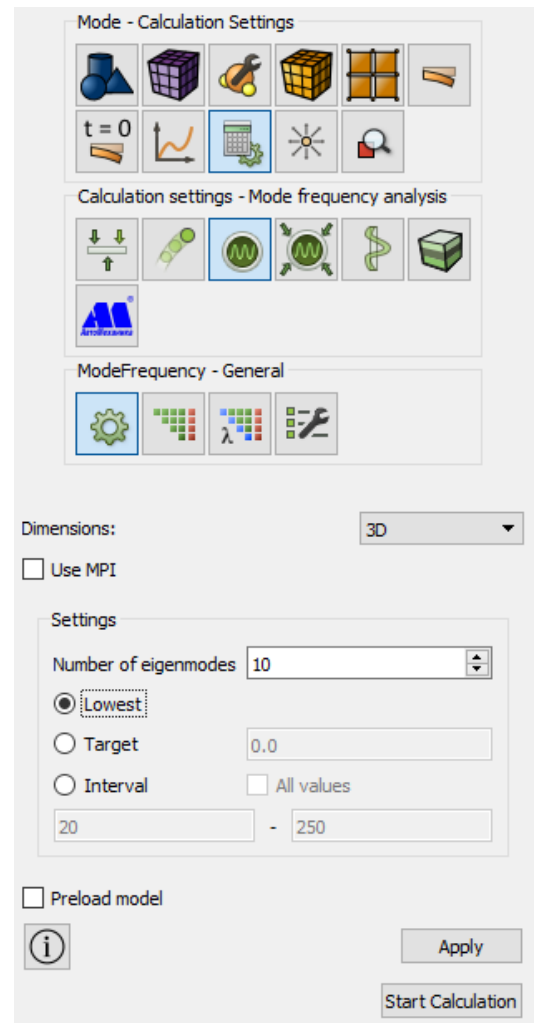

Results analysis

1. Compare the obtained results to those given in the picture.

```
FidesysCalc parse fc done
EIGENFREQUENCY
Number Eigenfrequency
1 2.399179 Hz
2 6.094884 Hz
3 6.109600 Hz
4 10.049814 Hz
5 12.473924 Hz
6 12.538575 Hz
7 16.696024 Hz
8 16.818848 Hz
9 21.961975 Hz
10 22.033991 Hz
```

```
Case 1. Done. Successfully.
Calculation finished.
Calculation finished successfully at 2019-02-26 16:53:06
```

2. Open the file with the results. You can do this in one of the three ways.

- Click Ctrl+E.
- Select **Calculation** → **Open Results** in the Main Menu. Click **Open last result**.
- Select **Results** on Command Panel (Mode — **Results**). Click **Open Results**.

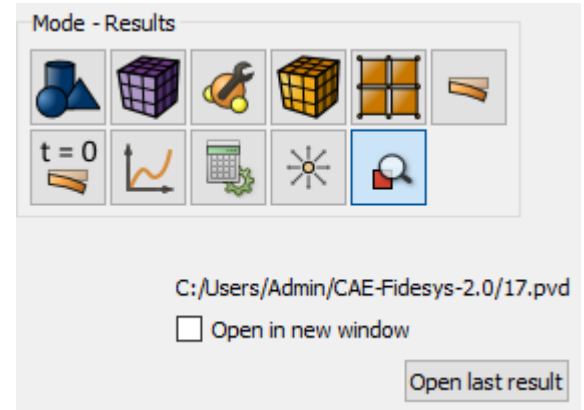
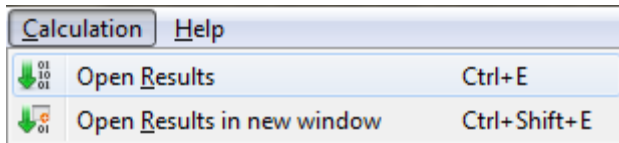

3. You can see the way the body is deformed under the applied pressure.

Select a filter **Warp By Vector** to do this. Set the following parameters in the tab **Properties**:

- Vectors: Eigenvalue_# (*# stands for the number of the eigenvalue*);
- Scale Factor: 200.

As a result, the deformed body is displayed at the picture. To see the original model, click  near it in the Model Tree. The picture below shows the deformed model at different eigenvalues.

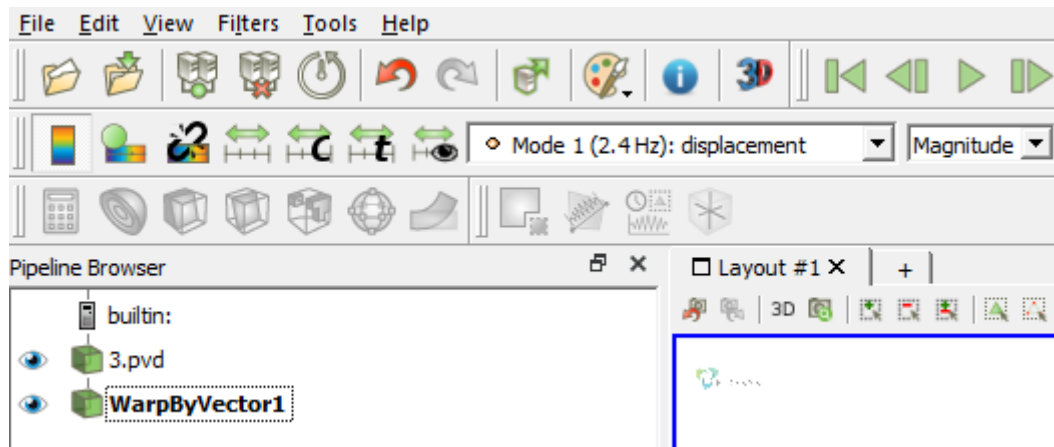

4. Display the 3D-view of the model (shell with thickness).



To do this, click on the name of the source file in the Model Tree. After this click 3D-view button in the default string.

The file *_3D.pvd with a 3D-image of the shell must be opened and you will be able to apply various filters to it and to view its deformed view.

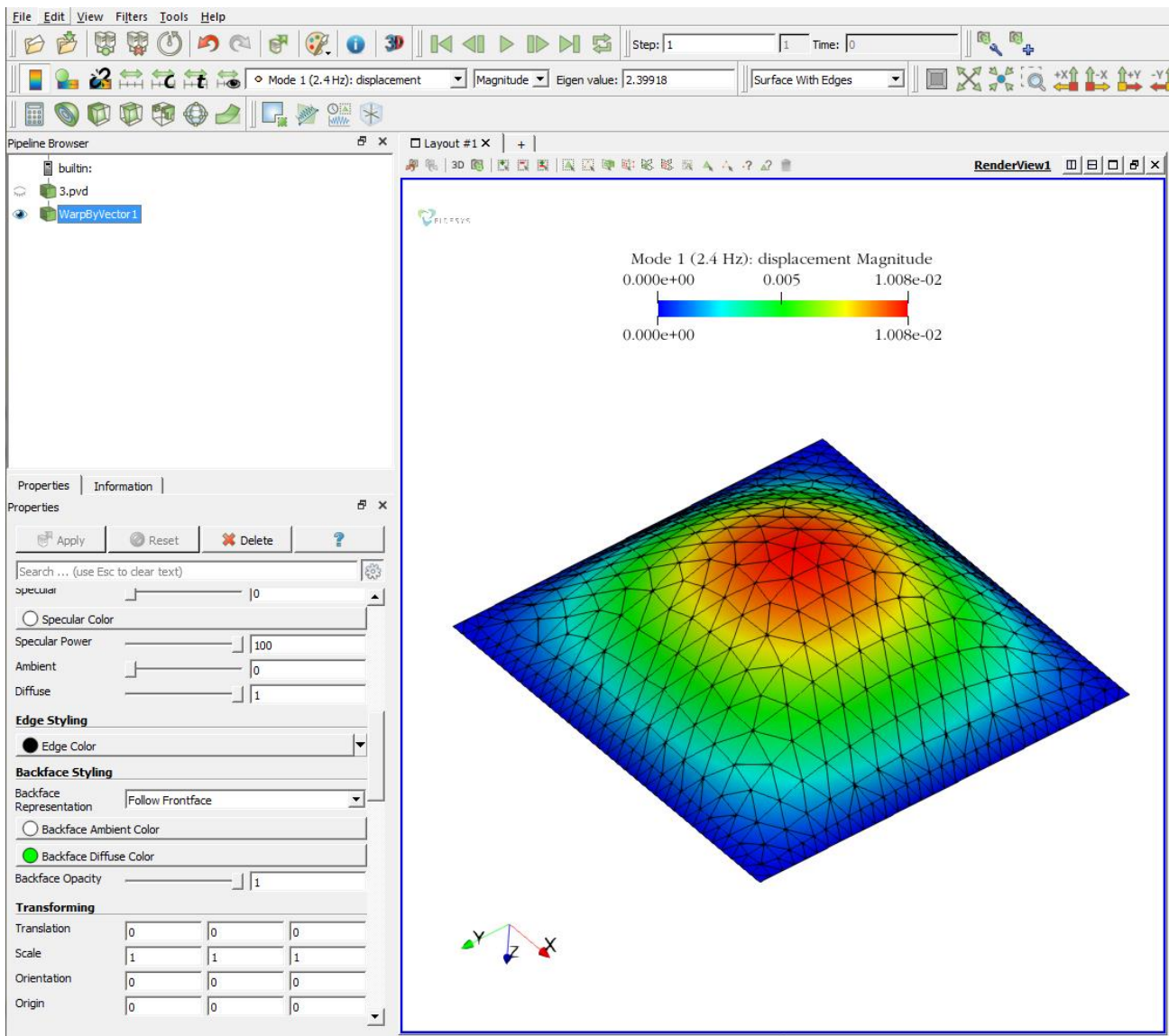

Using Console Interface

For geometry generation, meshing, setting boundary conditions and materials you can use Console Interface. The following program code allows performing the steps of the above-described guide, you only need to **manually** specify the full path and name of the file to be saved.

```

reset
set node constraint on
create surface rectangle width 10 zplane
curve all interval 32
curve all scheme equal
surface 1 scheme Auto
surface 1 scheme Auto
mesh surface 1
create displacement on node all dof 1 dof 2 dof 6 fix 0
create displacement on curve all dof 3 fix 0
create displacement on curve 2 4 dof 4 fix 0
create displacement on curve 1 3 dof 5 fix 0
create material 1
modify material 1 name 'Material1'
modify material 1 set property 'MODULUS' value 2e+11
modify material 1 set property 'POISSON' value 0.3
    
```

```

modify material 1 set property 'DENSITY' value 8000
set duplicate block elements off
block 1 add surface 1
block 1 material 'Material1'
block 1 element shell order 1
block 1 attribute count 2
block 1 attribute index 1 value 0.05
block 1 attribute index 2 value 0.5
analysis type eigenfrequencies dim3 preload off
eigenvalue find 10 smallest
calculation start path 'D:/Fidesys/example.pvd'
    
```



It is also possible to run the file *Example_8_Eigenvalue_Shell.jou*, by selecting Journal Editor on Toolbar. In a pop-up window of the main menu select **File** → **Open** and open the necessary journal file.

Setting heat transfer (3D, working with two blocks)

The 3D problem of a hollow two-material cylinder which inner and outer surfaces undergo the convection is being solved.

The pictures represent a geometric model of the problem:

The inner radius of the cylinder $R_i = 0.30$ m, the middle radius of the cylinder (at the place of material changing) $R_m = 0.35$ m, the external radius of the cylinder $R_e = 0.37$ m.

Convective heat exchange with internal temperature $T_i = 70$ °C and coefficient $h_i = 150$ W/m²/°C occurs on the inner surface of the cylinder. Convective heat exchange with exterior temperature $T_e = -15$ °C and coefficient $h_e = 200$ W/m²/°C occurs on the outer surface of the cylinder.

Materials are isotropic. The material heat transfer 1 is $V_1 = 40$ W/(m·°C). The material heat transfer 2 is $V_2 = 20$ W/(m·°C).

Test pass criterion is the following:

at the point (0.3, 0, 0) heat flux 6687 W/m² is within 1%.

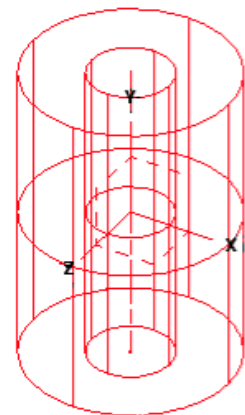
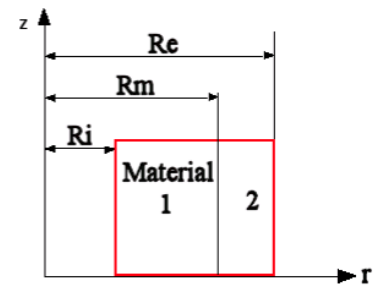

Geometry creation

1. Create the first cylinder.

Select volume geometry generation section on Command Panel (Mode – **Geometry**, Entity – **Volume**, Action – **Create**). Select **Cylinder** in the list of geometric elements. Specify the cylinder dimensions:

- Height: 0.01;
- Circular;
- Radius: 0.3.

Click **Apply**.

2. Create the second cylinder.

Select volume geometry generation section on Command Panel (Mode — **Geometry**, Entity — **Volume**, Action — **Create**). Select **Cylinder** in the list of geometric elements. Specify the cylinder dimensions:

- Height: 0.01;
- Circular;
- Radius: 0.35.

Click **Apply**.

3. Create the third cylinder.

Select volume geometry generation section on Command Panel (Mode — **Geometry**, Entity — **Volume**, Action — **Create**). Select **Cylinder** in the list of geometric elements. Specify the cylinder dimensions:

- Height: 0.01;
- Circular;
- Radius: 0.37.

Click **Apply**.

As a result, three generated entities are displayed in the Model Tree (Volume 1, Volume 2 and Volume 3).

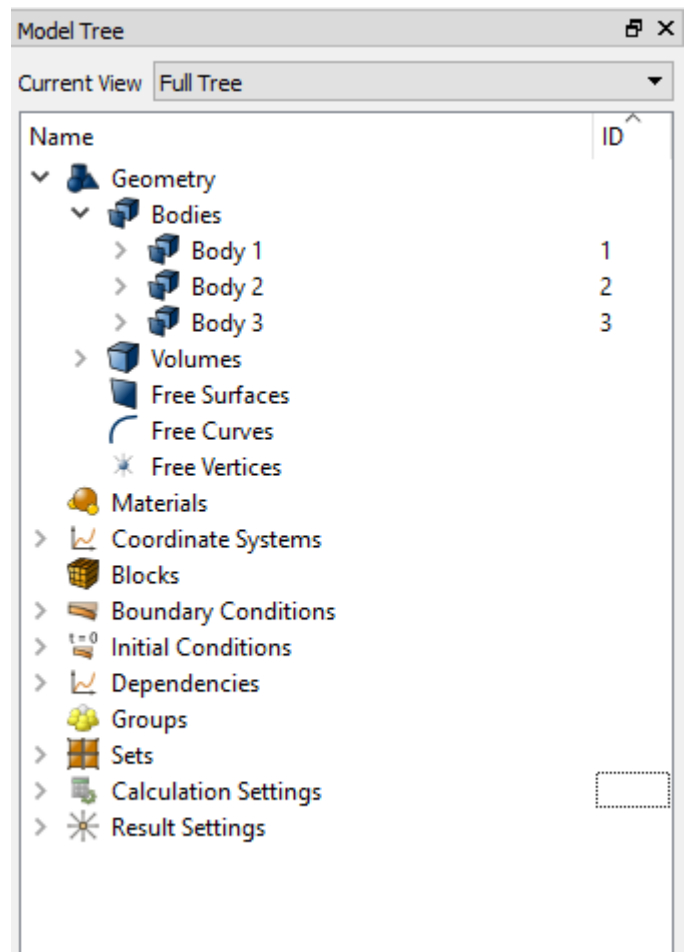
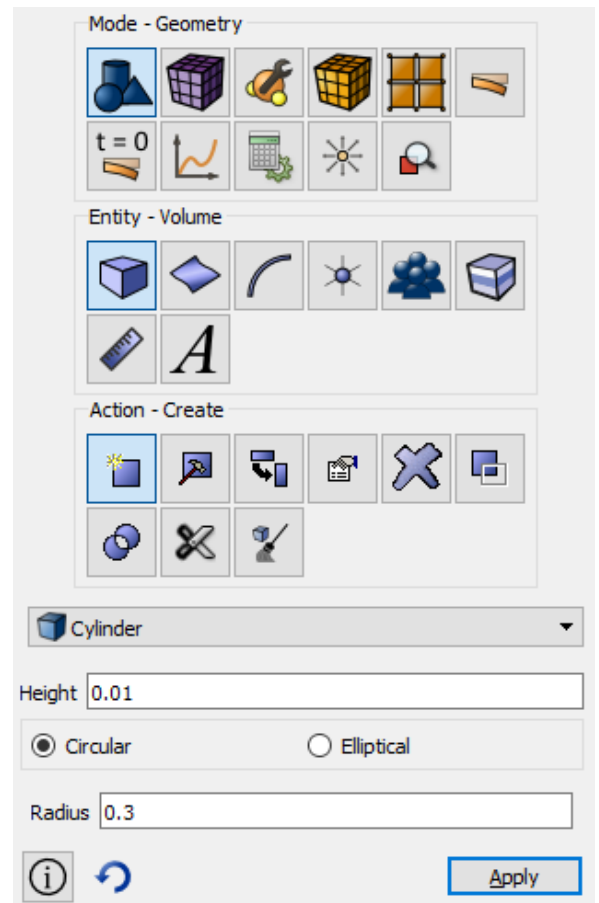

4. Subtract the first cylinder from the second one.

Select volume geometry generation section on Command Panel (Mode — **Geometry**, Entity — **Volume**, Action — **Boolean**). Select **Subtract** in the list of operations. Set the following parameters:

- Body ID: 2 (*volumes from which other volumes will be subtracted*);
- Subtract bodies (ID): 1 (*the volumes to be subtracted*);
- Keep Originals.

Click **Apply**.

5. Subtract the second cylinder from the third one.

Select volume geometry generation section on Command Panel (Mode — **Geometry**, Entity — **Volume**, Action — **Boolean**). Select **Subtract** in the list of operations. Set the following parameters:

- Body ID: 3 (*volumes from which other volumes will be subtracted*);
- Subtract bodies (ID): 2 (*the volumes to be subtracted*);
- Keep Originals.

Click **Apply**.

As a result, five generated entities are displayed in the Model Tree: Volume 1, Volume 2, Volume 3, Volume 4 and Volume 5. Delete the thirt three bodies by right-clicking and selecting Delete.

Two entities: Volume 4 and Volume 5 are left in the Model Tree.

6. Merge obtained entities.

Select volume geometry generation section on Command Panel (Mode — **Geometry**, Entity — **Volume**, Action — **Impirint And Merge**). Select **Merge Volumes** in the list of operations. Set the following parameters:

- Body ID: 4 5 (*the volumes to be united*).

Click **Apply**.

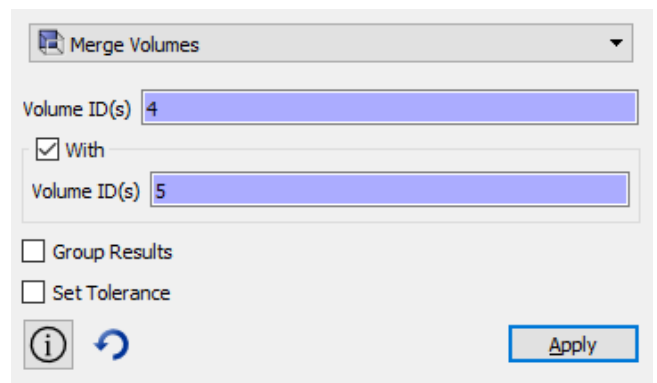
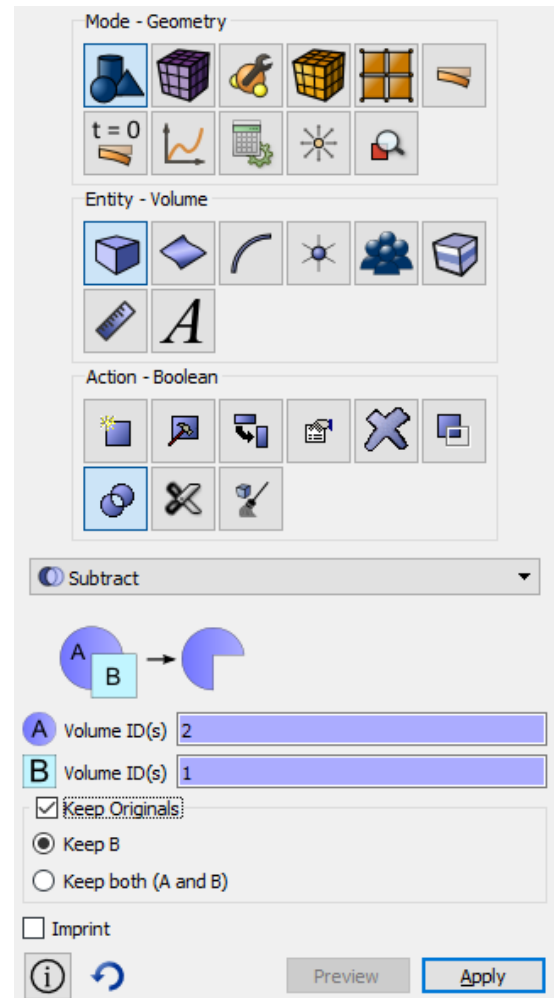

Meshing

1. Select meshing on curves section on Command Panel (Mode — **Mesh**, Entity — **Curve**, Action — **Mesh**). Specify the parameters of mesh refinement:

- Select Curves: all (*mesh will be creat on all the curves*);
- Select the way of meshing: Equal;
- Select the meshing parameters: Interval;
- Interval: 200.

Click **Apply Size**.

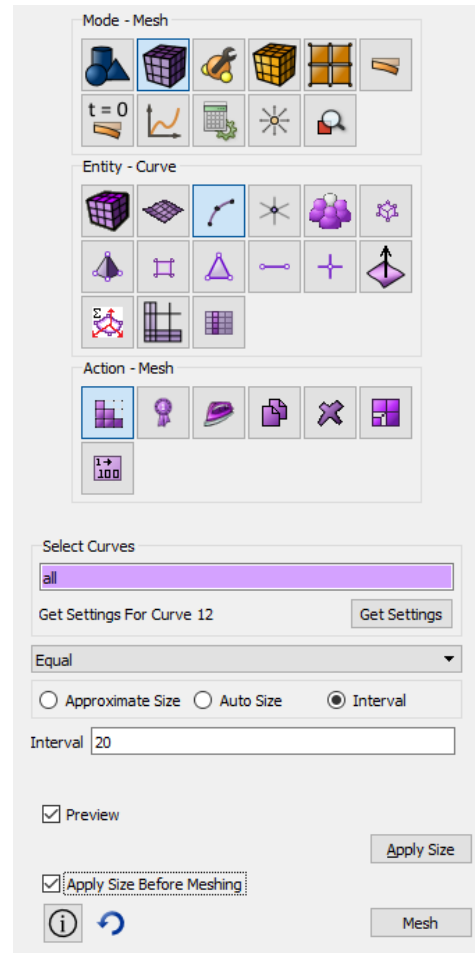

2. Select volume mesh generation section on Command Panel (Mode — **Mesh**, Entity — **Volume**, Action — **Mesh**).

- Select volumes: all (*mesh will be creat on all the volumes*);
- Select meshing scheme: Polyhedron.

Click **Apply Scheme**.

Click **Mesh**.

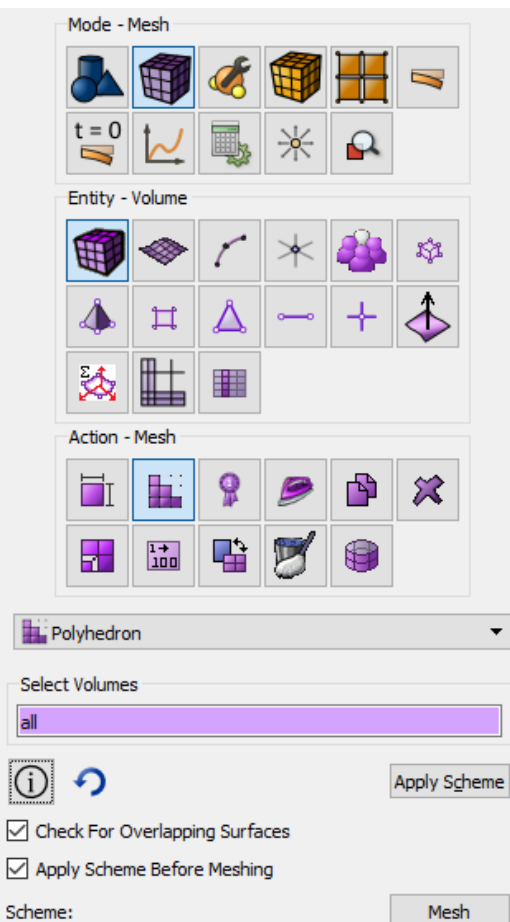

Setting material and element type

1. Create Material 1.

Select setting the material properties section on Command Panel (Mode — **Blocks**, Entity — **Materials management**).

Specify the name of the material. Material 1. Drag from the left column to the section Thermal of the label Thermal isotropic in the Material Properties column.

Set the following parameters:

- Thermal Expansion coefficient: 40.

Click **Apply**.

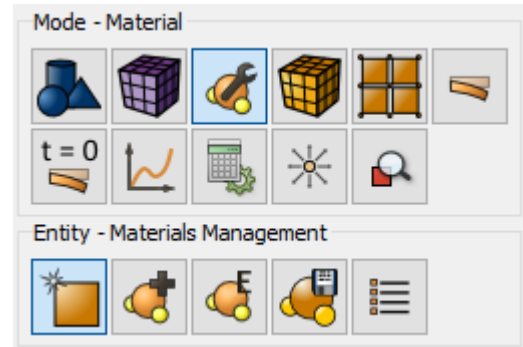

2. Create Material 2.

Select setting the material properties section on Command Panel (Mode — **Blocks**, Entity — **Materials management**).

Specify the name of the material. Material 1. Drag from the left column to the section Thermal of the label Thermal isotropic in the Material Properties column.

Set the following parameters:

- Thermal Expansion coefficient: 20.

Click **Apply**.

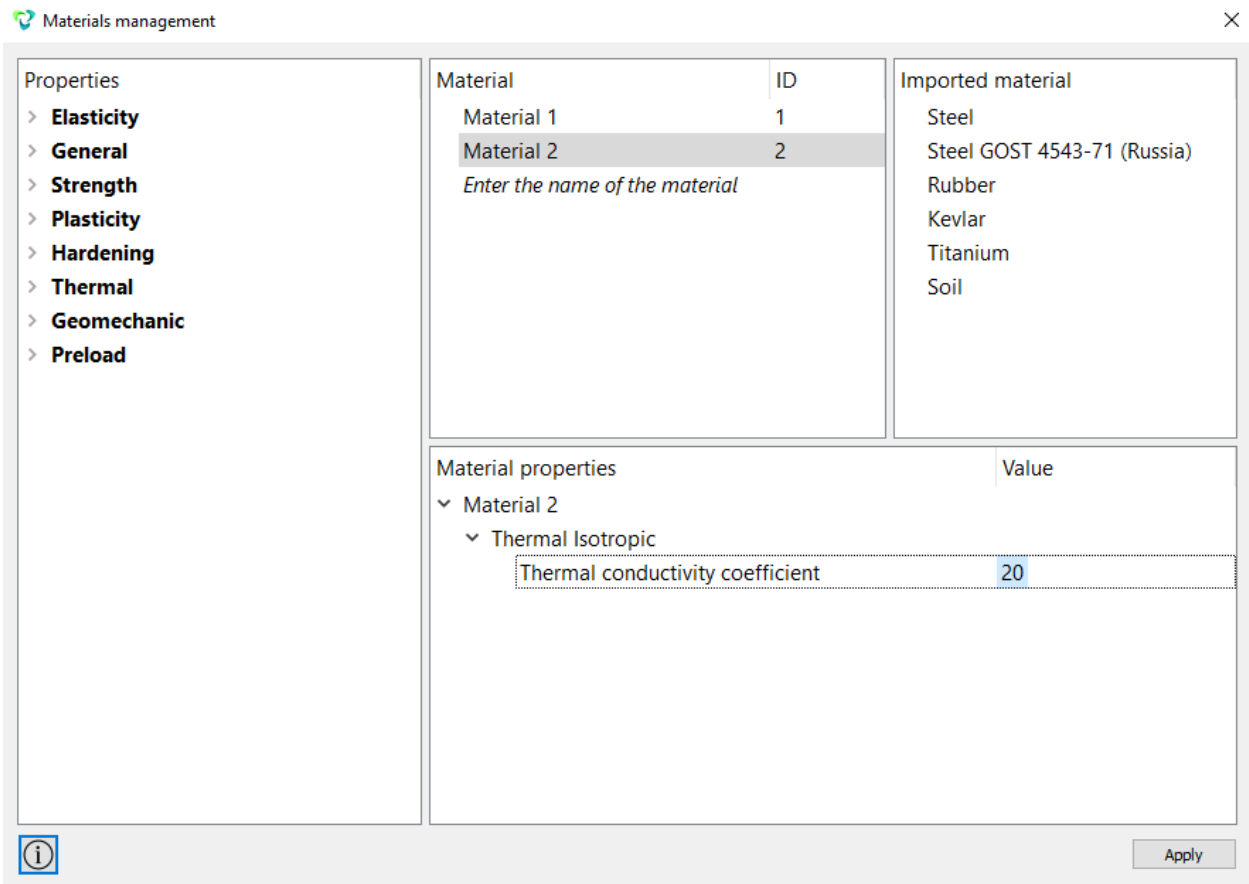

3. Create Block 1.

Select setting the material properties section on Command Panel (Mode — **Blocks**, Entity — **Block**, Action — **Add**). Set the following parameters:

- Block ID: 1;
- Entity list: Volume;
- ID: 4.

Click **Apply**.

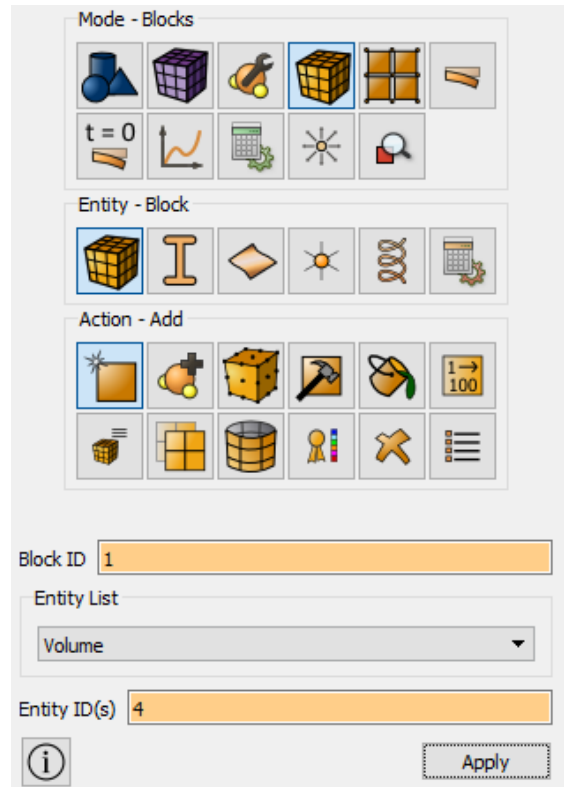

4. Assign the material to block 1.

Select setting the material properties section on Command Panel (Mode — **Blocks**, Entity — **Block**, Action — **Add**). Set the following parameters:

- Block ID(s): 1;
- Select the previously created material in the list: Material 1.

Click **Apply**.



5. Create Block 2.

Select setting the material properties section on Command Panel (Mode — **Blocks**, Entity — **Block**, Action — **Add**). Set the following parameters:

- Block ID: 2;
- Entity list: Volume;
- ID: 5.

Click **Apply**.

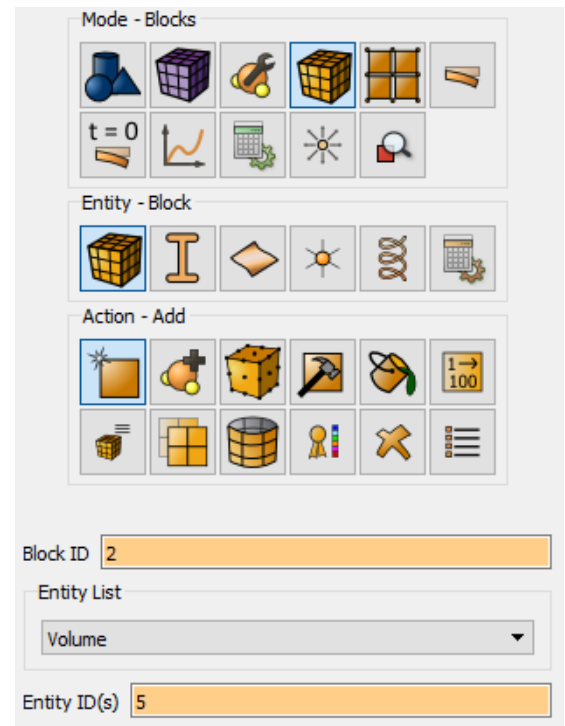

6. Assign the material to block №2.

Select setting the material properties section on Command Panel (Mode — **Blocks**, Entity — **Block**, Action — **Set material**). Set the following parameters:

- Block ID(s): 2;
- Select the previously created material in the list: Material 2.

Click **Apply**.

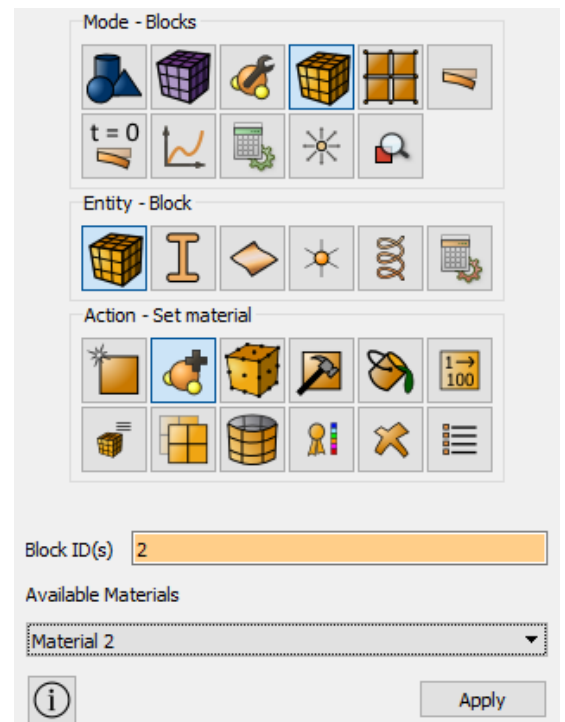

7. Assign the element type to the both of blocks.

Select setting the material properties section on Command Panel (Mode — **Blocks**, Entity — **Block**, Action — **Element Types**). Set the following parameters:

- Block ID(s): all;
- Select: Volumes;
- Order: 1.

Click **Apply**.

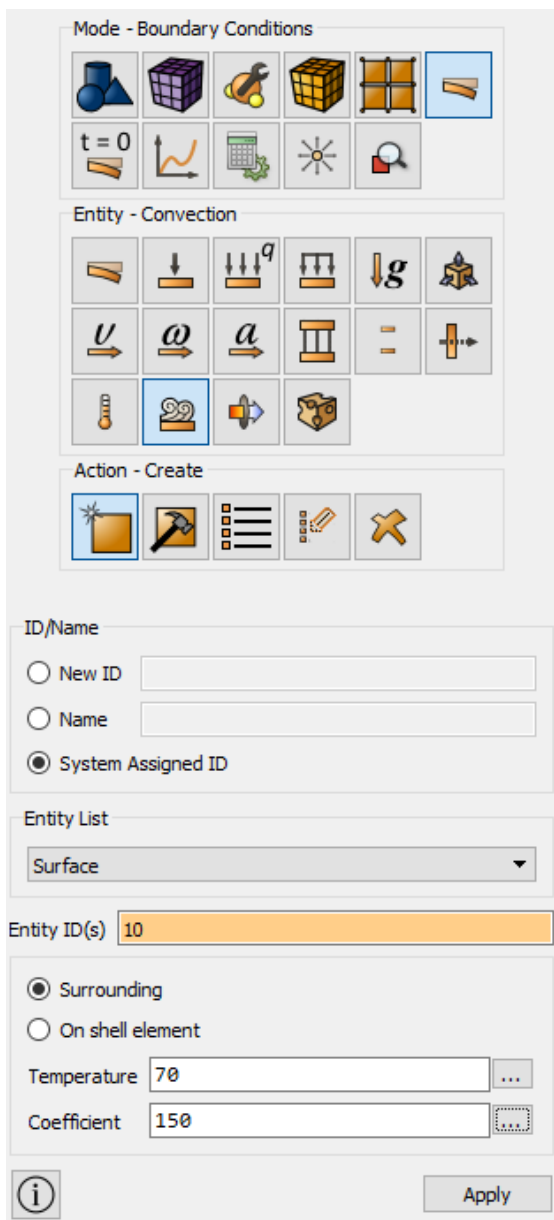
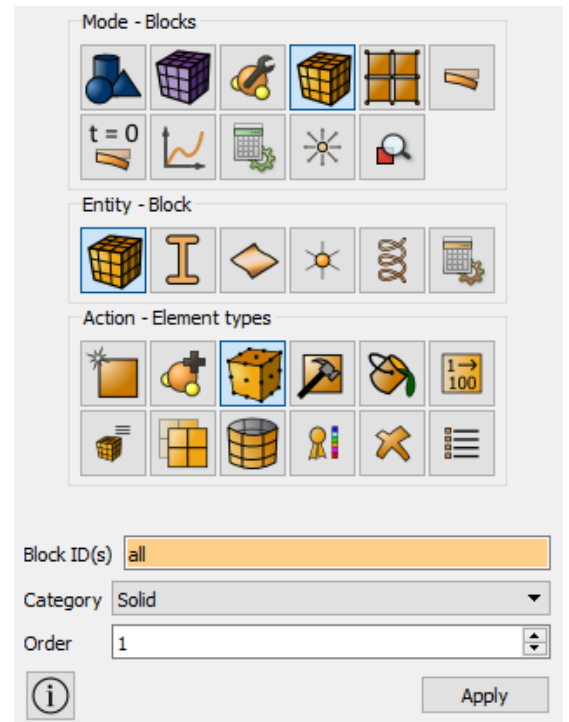

Setting boundary conditions

1. Set the process of convective heat exchange on the inner surface of the cylinder.

Select Mode — **Boundary Conditions**, Entity — **Convection**, Action — **Create** on Command Panel. Set the following parameters:

- System Assigned ID;
- Entity List: Surface;
- Entity ID(s): 10;
- Select the way of parameters setting: Surrounding;
- Temperature: 70;
- Coefficient: 150.

Click **Apply**.

2. Set the process of convective heat exchange on the outer surface of the cylinder.

Select Mode — **Boundary Conditions**, Entity — **Convection**, Action — **Create** on Command Panel. Set the following parameters:

- System Assigned ID;
- Entity List: Surface;
- Entity ID(s): 15;
- Select the way of parameters setting: Surrounding;
- Temperature: -15;
- Coefficient: 200.

Click **Apply**.

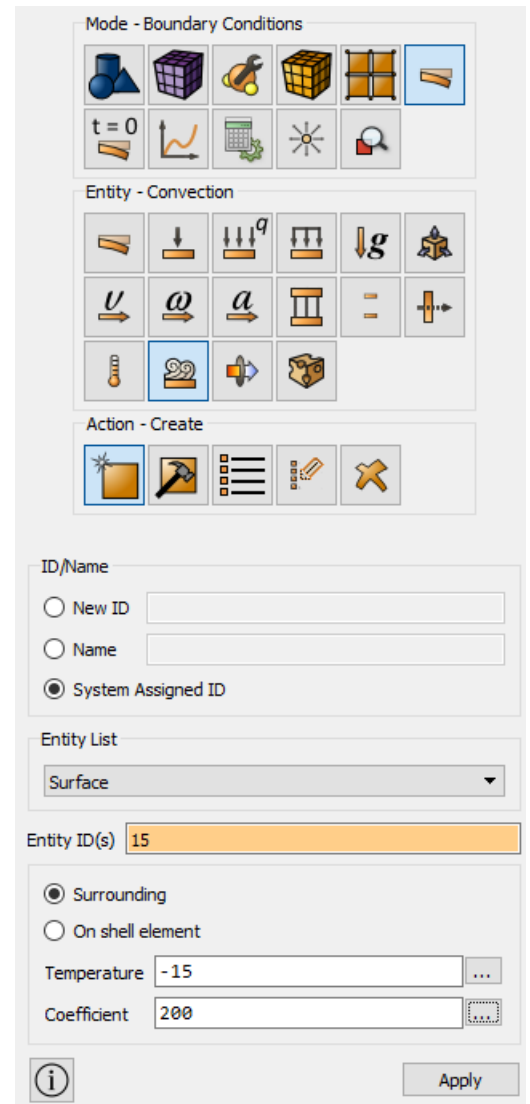

3. Fix the base of the cylinder.

Select Mode — **Boundary Conditions**, Entity — **Displacement**, Action — **Create** on Command Panel. Set the following parameters:

- System Assigned ID;
- Entity List: Surface;
- Entity ID(s): 12 13 16 17 (*using space after each of them*);
- Degrees of Freedom: Z-Translation;
- DOF Value: 0.

Click **Apply**.



Starting calculation

1. Set the type of the problem to be solved.

Select calculation setting section on Command Panel (Mode — **Calculation settings**, Calculation settings — **Static**, Static — **General**). Select Dimension — **3D**. Untick next to the item **Elasticity**. Tick next to the item **Heat transfer**.

Click **Apply**.

2. In a pop-up window select a folder to save the result and enter the file name.
3. If the calculation is finished successfully, you will see a message in the Console: "*Calculation finished successfully at <date> <time>*".

The screenshot displays the 'Mode - Calculation Settings' panel. It is divided into three sections: 'Calculation settings - Static', 'Static - General', and 'Model'. In the 'Model' section, the 'Elasticity' checkbox is unchecked, while 'Heat transfer' is checked. Below this, there are buttons for 'Apply' and 'Start Calculation'. The 'Dimensions' dropdown is set to '3D'. Below the calculation settings, the 'Mode - Results' panel is visible, showing a toolbar with various icons. At the bottom, the file path 'C:/Users/Admin/CAE-Fidesys-2.0/18.pvd' is shown, along with an 'Open last result' button.

Results analysis

1. Open the file with the results. You can do this in one of the three ways.
 - Click Ctrl+E.
 - Select **Calculation** → **Open Results** in the Main Menu. Click **Open last result**.
 - Select **Results** on Command Panel (Mode — **Results**). Click **Open Results**.
2. Display the component of the heat flux.

In **Fidesys Viewer** window set the following parameters on Toolbar:

- Representation Mode: Surface;
- Representation Field: HeatFlux.



To display the color legend scale, click the button **Switch the color legend visibility** on Command Panel.

3. Select a point where you need to view the heat flux.

In the Main Menu, select the filter **Probe Location**. In the tab **Properties** set the coordinates of the point A where you need to view the stress:

- Show Point;
- Point (coordinates): 0.3 0 0;
- Number of Points: 1;
- Radius: 0.

Click **Apply**.



To apply all of the filters changes automatically, click **Apply changes to parameters automatically** on Command Panel.

As a result, point A is displayed at the picture.

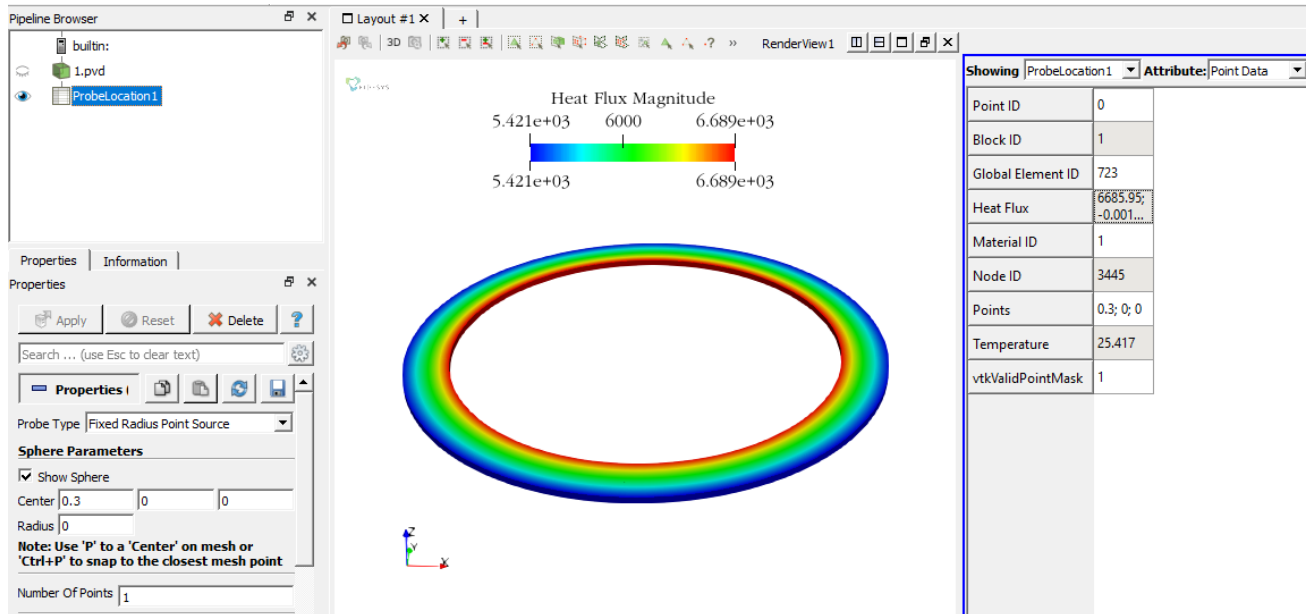

4. View a numerical value of the heat flux φ at the selected point A.

See the heat flux values in the line **HeatFlux** in the tab **Information** in the field **Data Arrays**.

Information

Data Arrays		
Current data time: 1		
Name	Data Type	Data Ranges
Block ID	[1, 1]	
Global Element ID	[723, 723]	
Heat Flux	[6685.95, 6685.95], [6685.95, 6685.95], [-0.00151785, -0.00151785], [9.66712e-11, 9.66712e-11]	
Material ID	[1, 1]	
Node ID	[3445, 3445]	
Temperature	[25.417, 25.417]	
vtkValidPointMask	[1, 1]	

The heat flux value is calculated using the following formula:

$$\sqrt{\varphi_x^2 + \varphi_y^2 + \varphi_z^2} = \sqrt{6686.41^2 + (-0.00302395)^2 + (8.02105e-05)^2} = 6686.41$$

The difference between the obtained value 6686.41 and the required one 6 687 is 0.01%.

5. Download numerical data.



Select **File** → **Save Data** in the Main Menu or click **Ctrl+S**. Enter the file name (*.csv format), leave it by default. Click **OK**. The saved file is an ordinary table of numerical data which can be opened in any text editor.

Using Console Interface

For geometry generation, meshing, setting boundary conditions and materials you can use Console Interface. The following program code allows performing the steps of the above-described guide, you only need to **manually specify the full path and name of the file to be saved**.

```
reset
create Cylinder height 0.01 radius 0.3
create Cylinder height 0.01 radius 0.35
create Cylinder height 0.01 radius 0.37
subtract body 1 from body 2 keep
subtract body 2 from body 3 keep
delete body 1 2 3
merge volume 4 5
curve all interval 200
curve all scheme equal
volume all scheme Polyhedron
mesh volume all
create material 1
modify material 1 name 'Material 1'
modify material 1 set property ' ISO_CONDUCTIVITY ' value 40
create material 2
modify material 2 name 'Material 1'
modify material 2 set property ' ISO_CONDUCTIVITY ' value 20
block 1 volume 4
block 1 material 'Material 1'
block 2 volume 5
block 2 material 'Material 2'
block all element solid order 2
create convection on surface 10 surrounding 70 coefficient 150
create convection on surface 15 surrounding -15 coefficient 200
create displacement on surface 12 13 16 17 dof 3 fix 0
analysis type static heattrans dim3
calculation start path " D:/Fidesys/example.pvd"
```



It is also possible to run the file *Example_9_Static_3D_Conduction.jou*, by selecting Journal Editor on Toolbar. In a pop-up window of the main menu select **File** → **Open** and open the necessary journal file.

Dynamic load: nonsteady heat transfer (3D, implicit scheme)

The 3D problem of 1D nonsteady heat transfer inside a beam is being solved.

The picture below represents a geometric model of the problem:

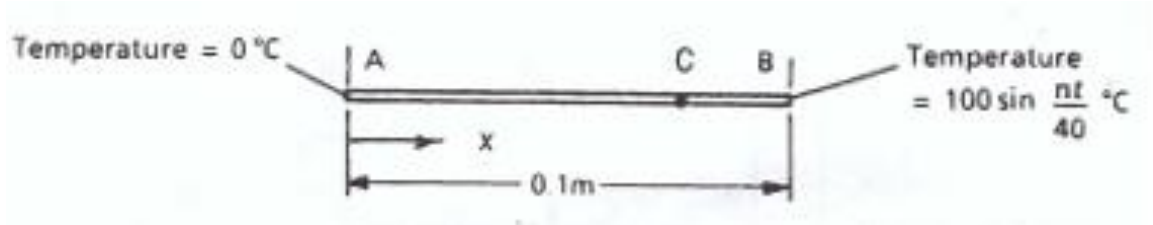

The beam length is 0.1 m, square cross section is 0.01x0.01 m. The temperature at the point A is $T_A = 0 \text{ }^\circ\text{C}$, the temperature at the point B varies harmonically: $T_B = 100 \sin \frac{\pi t}{40} \text{ }^\circ\text{C}$. The material parameters are isotropic, $V = 35 \text{ W}/(\text{m}\cdot^\circ\text{C})$, $C = 440.5 \text{ J}/(\text{kg}\cdot^\circ\text{C})$, $\rho = 7200 \text{ kg}/\text{m}^3$.

Test pass criterion is the following: temperature T at the point C (0.8;0;0) at time $t = 32c$ is 36.60°C within 2%.

Geometry creation

1. Create the sliver parallelepiped.

Select volume geometry generation section on Command Panel (Mode — **Geometry**, Entity — **Volume**, Action — **Create**). Select **Brick** in the list of geometric elements. Set the brick dimensions:

- Width: 0.1;
- Height: 0.01;
- Depth: 0.01.

Click **Apply**.

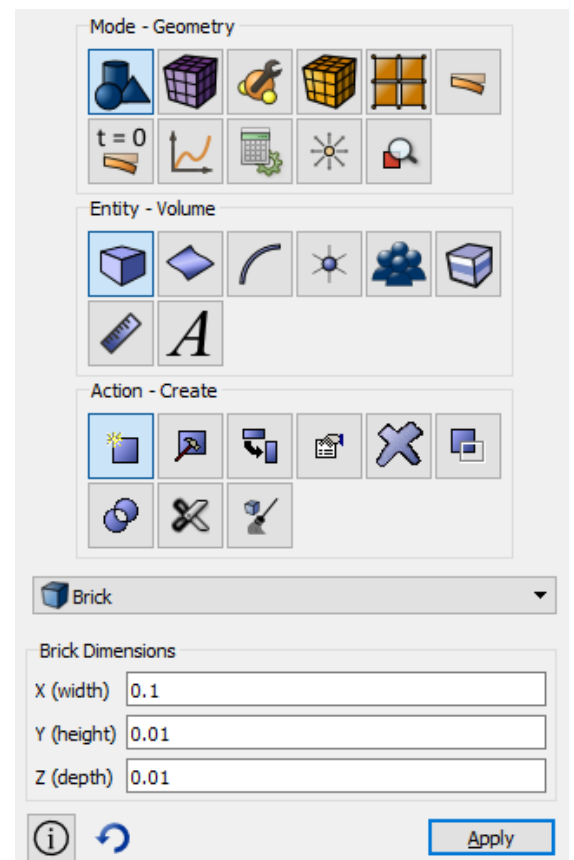

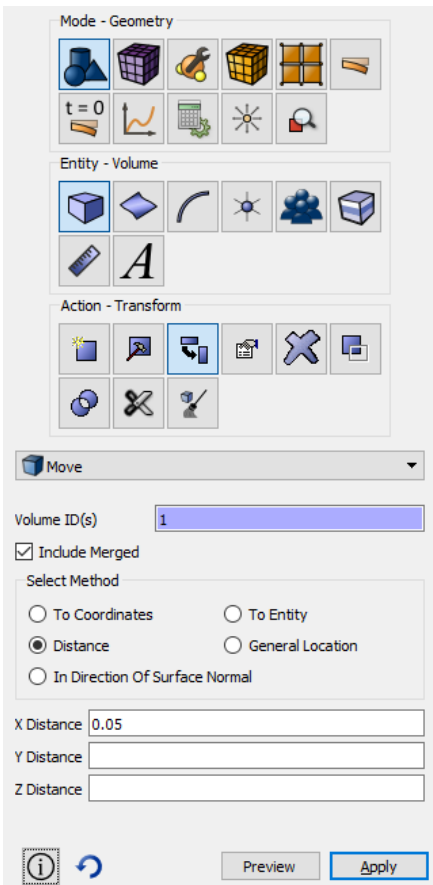

2. Combine left edge of the beam with the origin of coordinates.

Set the following parameters: Select volume geometry modification section on Command Panel (Mode — **Geometry**, Entity — **Volume**, Action — **Transform**). Select **Move** in the list of possible webcut types. Set the following parameters:

- Volume: 1;
- Select method: Distance;
- X Distance: 0.05.

Click **Apply**.

Meshing

1. Create the mesh of hexahedrons.

Select volume mesh generation section on Command Panel (Mode — **Mesh**, Entity — **Volume**, Action — **Mesh**):

- Select Volumes (specify their ID): 1 (or by the command **all**);
- The way of meshing: Polyhedron.

Click **Apply Scheme**.

Click **Mesh**.

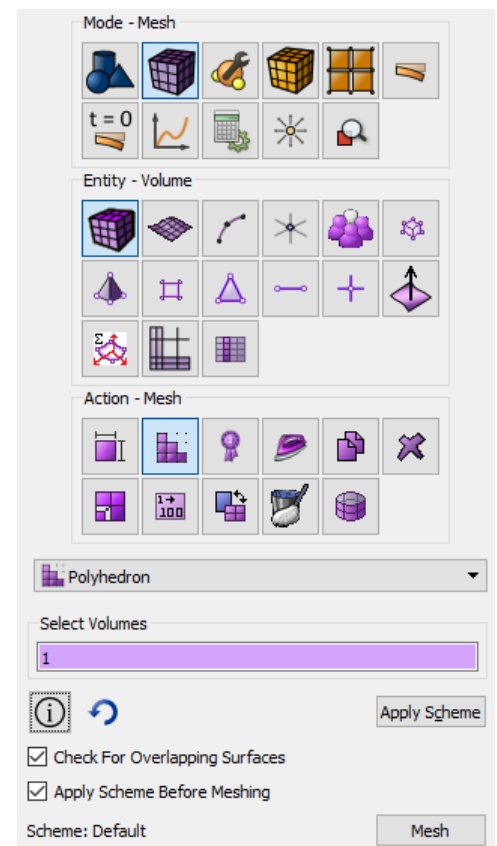

Setting material and element type

1. Create the material.

Select setting the material properties section on Command Panel (Mode — **Material**, Entity — **Materials management**).

In the Materials Management window that opens, in the second column, click on the caption Enter the name of the material and write "Material 1". Press the ENTER key.

Select setting the material properties section on Command Panel (Mode — **Blocks**, Entity — **Material**, Action — **Create Material**). Enter the name for the material. Set the following parameters:

- Density: 7200;
- Specific Heat coefficient: 440.5;
- Thermal conductivity coefficient: 35.

Click **Apply**.

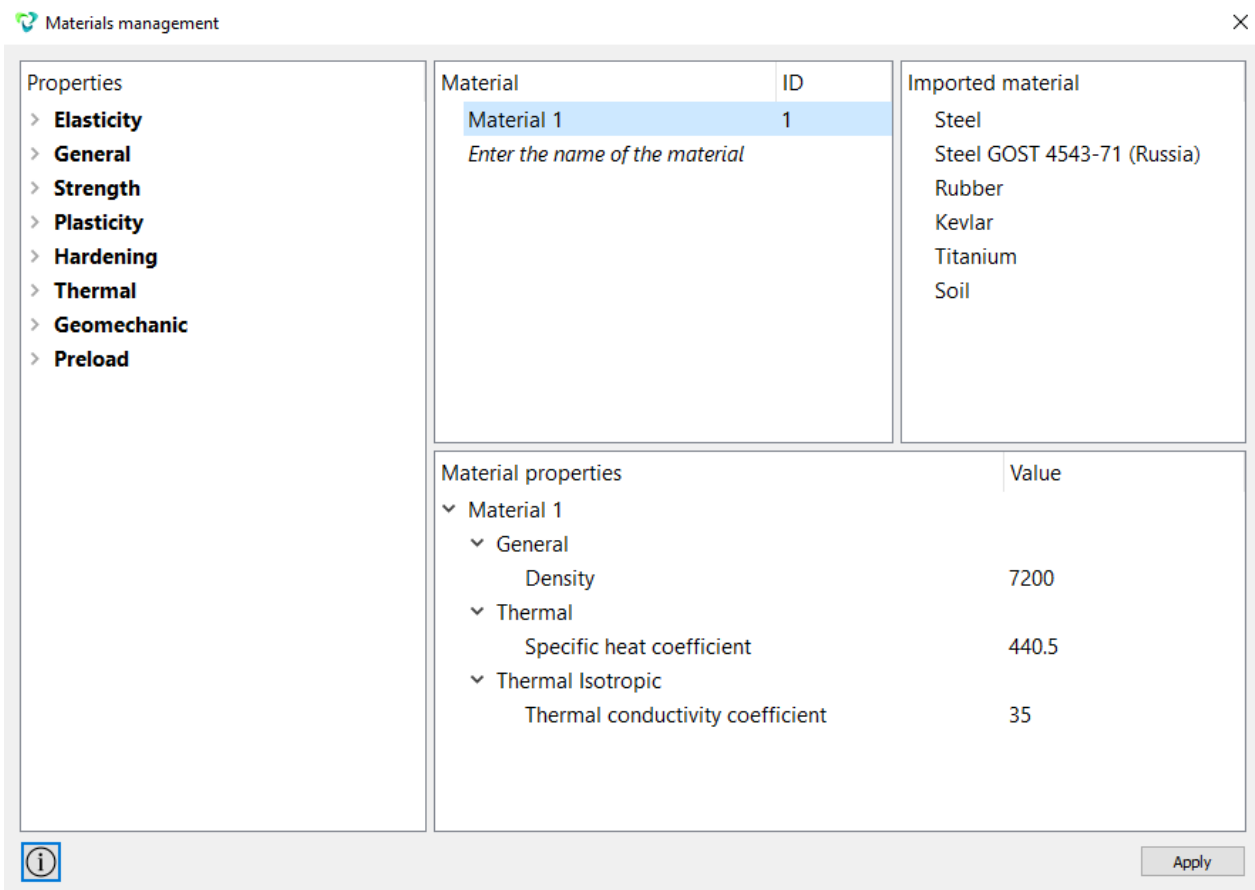
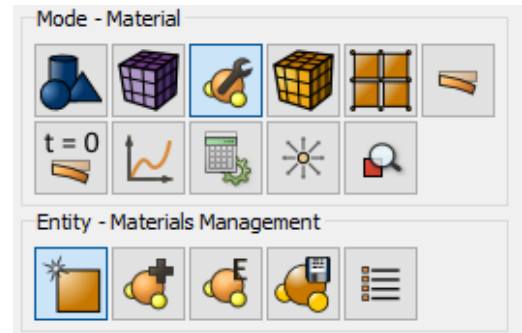

2. Create a block of one type of the material.

Select setting the material properties section on Command Panel (Mode — **Blocks**, Entity — **Block**, Action — **Manage**). Select **Add** in the list of possible operations. Set the following parameters:

- Block ID: 1;
- Entity list: Volume;
- ID: 1 (or by the command **all**).

Click **Apply**.

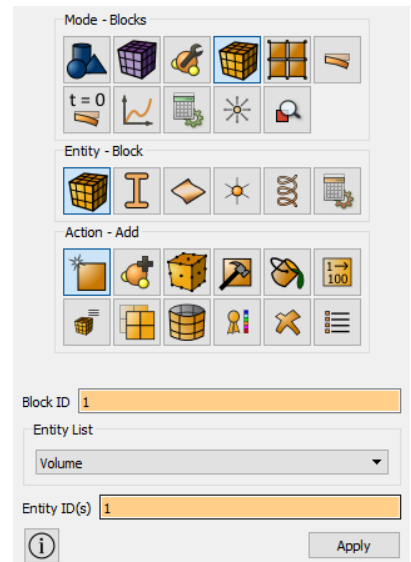

3. Assign the material to the block.

Select setting the material properties section on Command Panel (Mode — **Blocks**, Entity — **Block**, Action — **Set material**). Set the following parameters:

- Block ID(s): 1;
- Available materials: Material 1.

Click **Apply**.

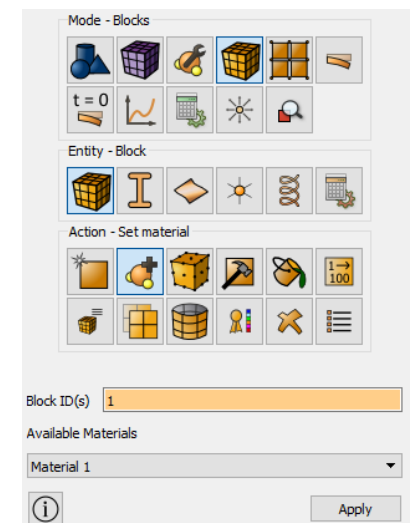

4. Assign the element type.

Select setting the material properties section on Command Panel (Mode — **Blocks**, Entity — **Block**, Action — **Element Types**). Set the following parameters:

- Block ID(s): 1;
- Select: Volumes;
- Order: 1.

Click **Apply**.

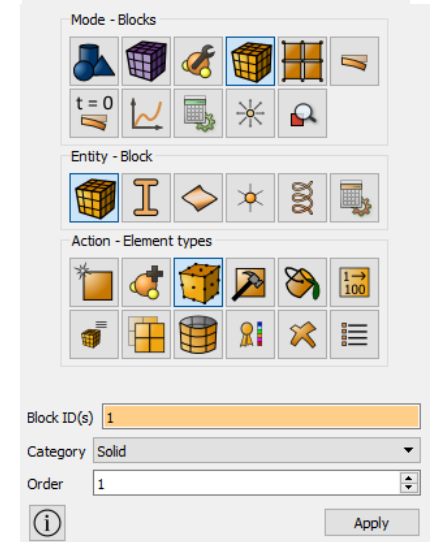

Setting boundary conditions

1. Set the value of temperature applied to the left side of the beam.

Select Mode — **Boundary Conditions**, Entity — **Temperature**, Action — **Create** on Command Panel. Set the following parameters:

- System Assigned ID;
- Temperature Entity List: Surface;
- Entity ID(s): 4;
- Temperature Value: 0.

Click **Apply**.

2. Set the value of temperature applied to the right side of the beam.

Select Mode — **Boundary Conditions**, Entity — **Temperature**, Action — **Create** on Command Panel. Set the following parameters:

- System Assigned ID;
- Temperature Entity List: Surface;
- Entity ID(s): 6;
- Temperature Value: 1.

Click **Apply**.

Setting time dependency of boundary conditions

1. Set time dependency of the temperature applied to the right edge of the beam.

Select Mode — **Boundary Conditions**. Click on the button **Time dependency** on Command Panel. The pop-up menu with the settings will be opened. On the left panel, select BC for which the time dependency will be set: **Temperature 2**. Put a checkbox next to the item **Formula**. Set the following parameters:

- Time dependency type: Manually;
- Enter formula: $100 * \sin(0.0785 * t)$.

Click **Apply**.

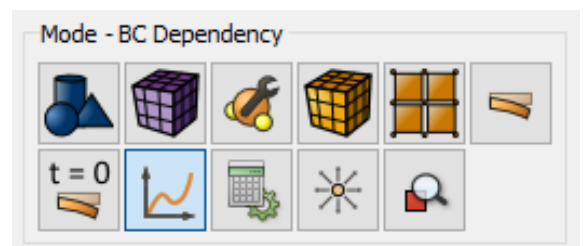
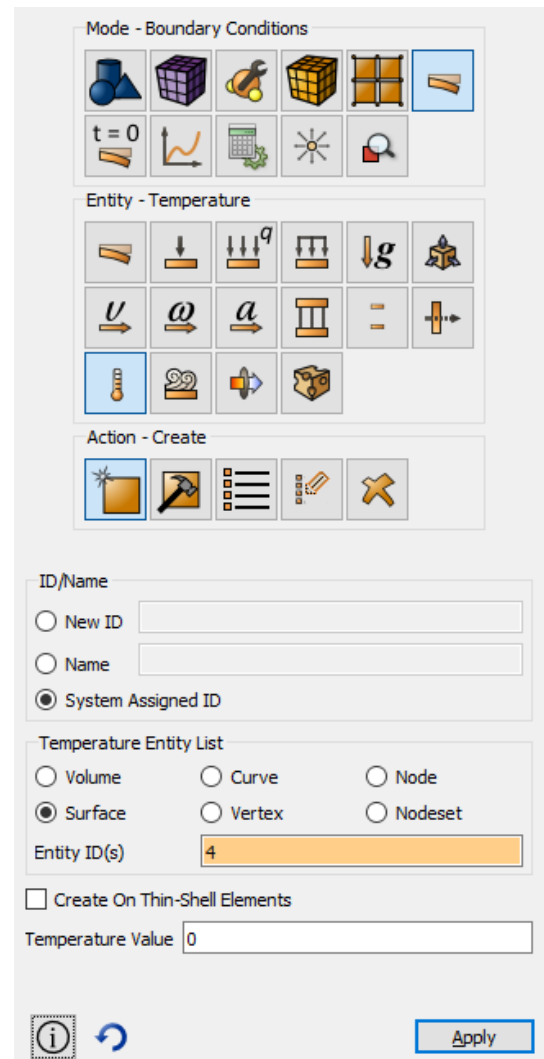



BC Dependency ×

BC Type	BC Name	ID
	Temperature	1
	Temperature	2

Formula Table Plot

Custom ▾

$100 * \sin(0.0785 * t)$

Clear + - * / ^

sin cos tan sqrt if(A,B,C) ()

asin acos atan exp log log10

sinh cosh tanh abs ceil floor

Available variables: t (time), x (x-coordinate), y (y-coordinate), z (z-coordinate), T (temperature), w (frequency)

Apply

Starting calculation

1. Set the type of the problem to be solved.

Select calculation setting section on Command Panel (Mode — **Calculation settings**, Calculation settings — **Transient analysis**, Transient analysis — **General**). Set the following calculation parameters:

- Dimension: 3D;
- Method: Full solution;
- Scheme: Implicit;
- Max time: 32;
- Steps count: 100.
- Elasticity: untick;
- Heat transfer: tick;
- Heat transfer: tick;

Click **Apply**.

Click **Start Calculation**.

In a pop-up window select a folder to save the result and enter the file name.

If the calculation is finished successfully, you will see a message in the Console: *"Calculation finished successfully at <date> <time>".*

Results analysis

1. Open the file with the results.

You can do this in one of the three ways:

- Click Ctrl+E.
- Select **Calculation** → **Open Results** in the Main Menu. Click **Open last result**.
- Select **Results** on Command Panel (Mode — **Results**). Click **Open last result**.

You can see the calculation results in the pop-up **Fidesys Viewer** window.

2. There is a menu on Toolbar which allows viewing animation. It consists of a cycle of solutions calculated for every moment of time. Click "Last Frame" to see the model in time moment $t = 32^{\circ}\text{C}$.

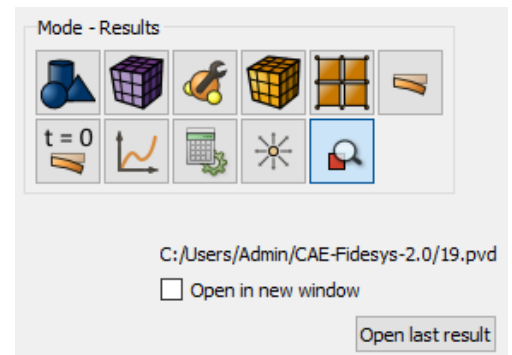
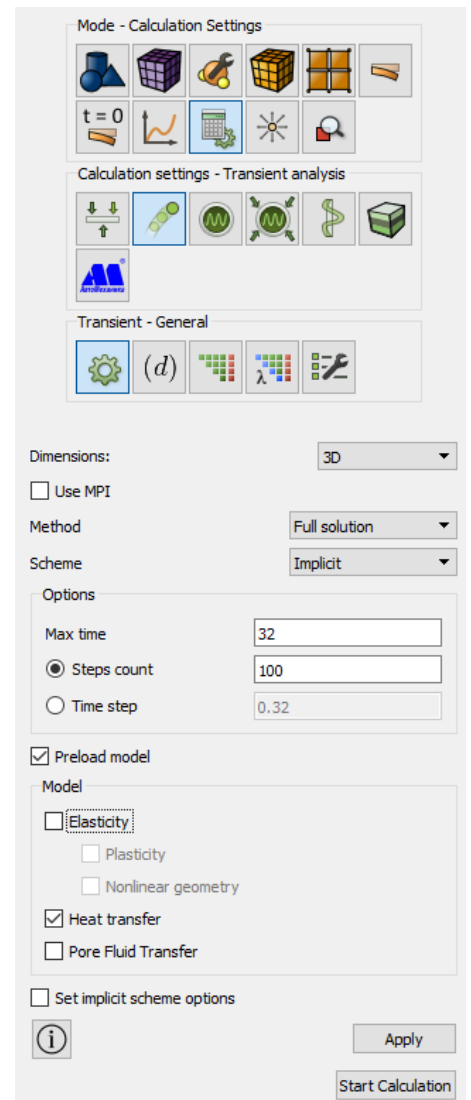
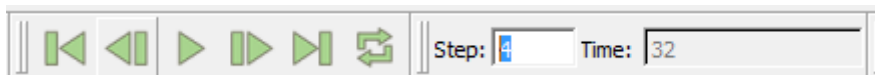

3. Display the component of the temperature.

In **Fidesys Viewer** window set the following parameters on Toolbar:

- Representation Field: Temperature;
- Representation Mode: Surface With Edges.

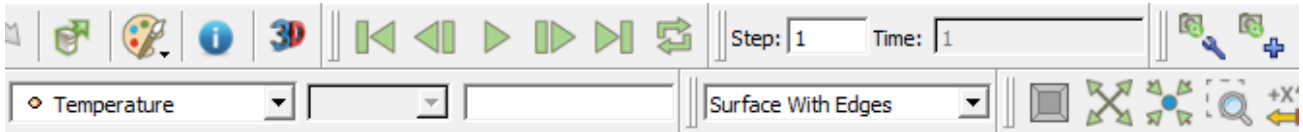

The model displays the mesh resulting from application of the spectral element method and the field of temperature distribution.



To display the color legend scale, click the button **Switch the color legend visibility** on Command Panel.

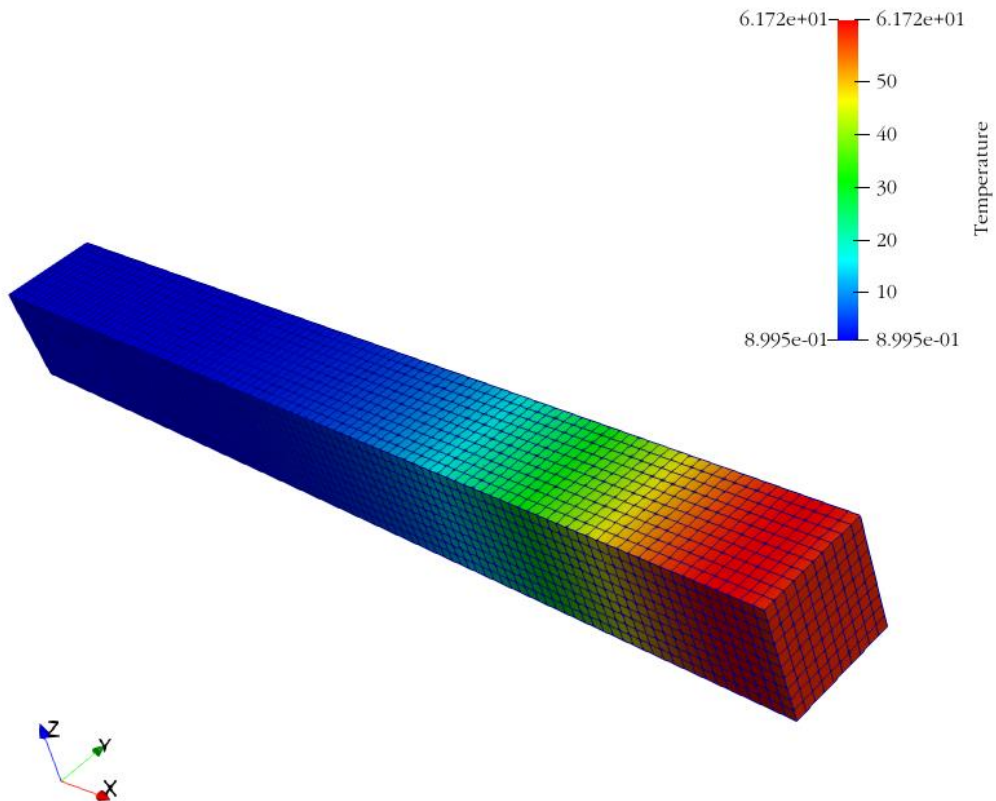

4. To graph along one of the beam edges.

Select the filter **Plot Over Line** in the Main Menu. Set the coordinates of the points defining the line In the tab **Properties**:

- Source: High Resolution Line;
- Show Line;
- Point 1 (coordinates): 0 -0.005 0.005;
- Point 2 (coordinates): 0.1 -0.005 0.005;
- Resolution: 100;
- PassPartialArrays

Click **Apply**.



To apply all of the filters changes automatically, click **Apply changes to parameters automatically** on Command Panel.

Click on the graph window appeared on the right side of the screen.

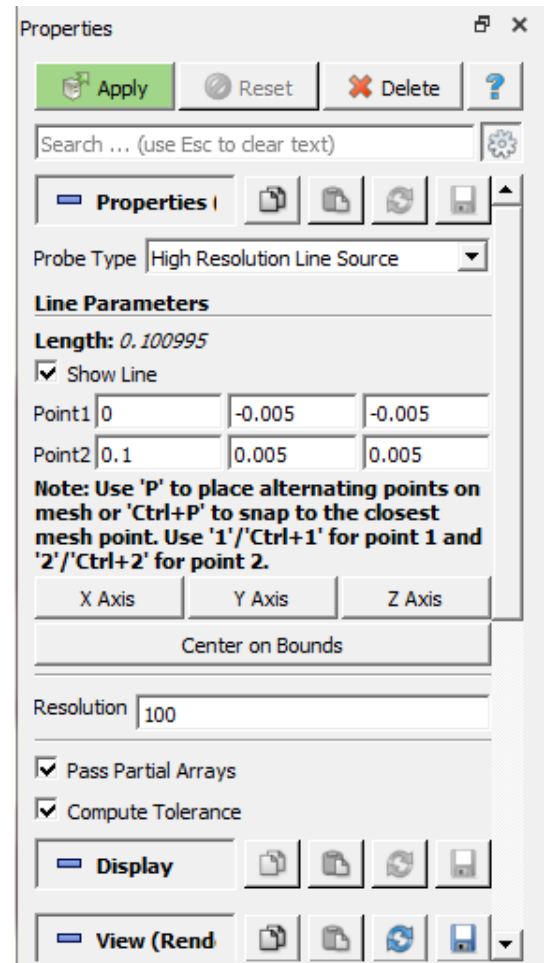

5. Display temperature change on the graph.

Click on the graph window, go to the tab "Display" in the filter control panel.

Set the **Attribute Mode – Point Data**

Next, in the field "Line Series", set up labels against the parameters that you want to display on the graph.

Untick all the options except Temperature.

The temperature dependency at points belonging to the beam edge and the coordinates of these point coordinates are displayed on the graph.

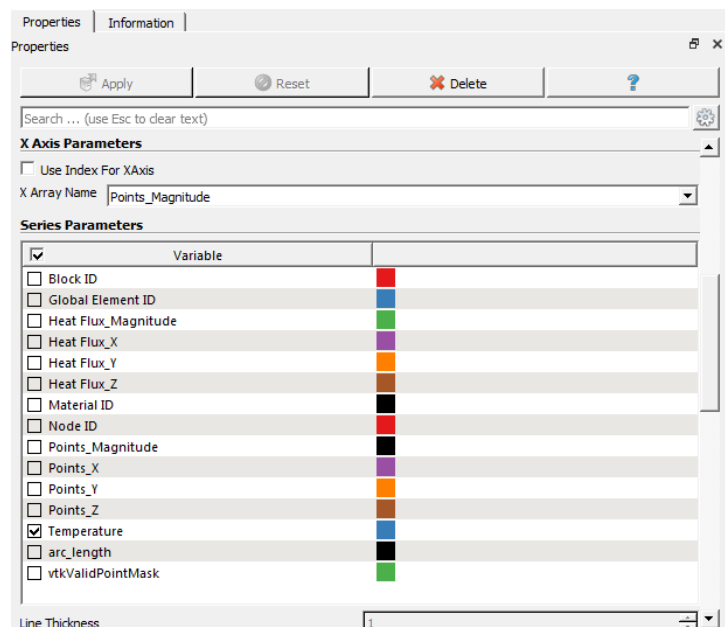

6. Check the numerical temperature value T at the point (0.08;0;0).

Move the cursor to the required point on the graph. You can see a tool tip with the temperature value.

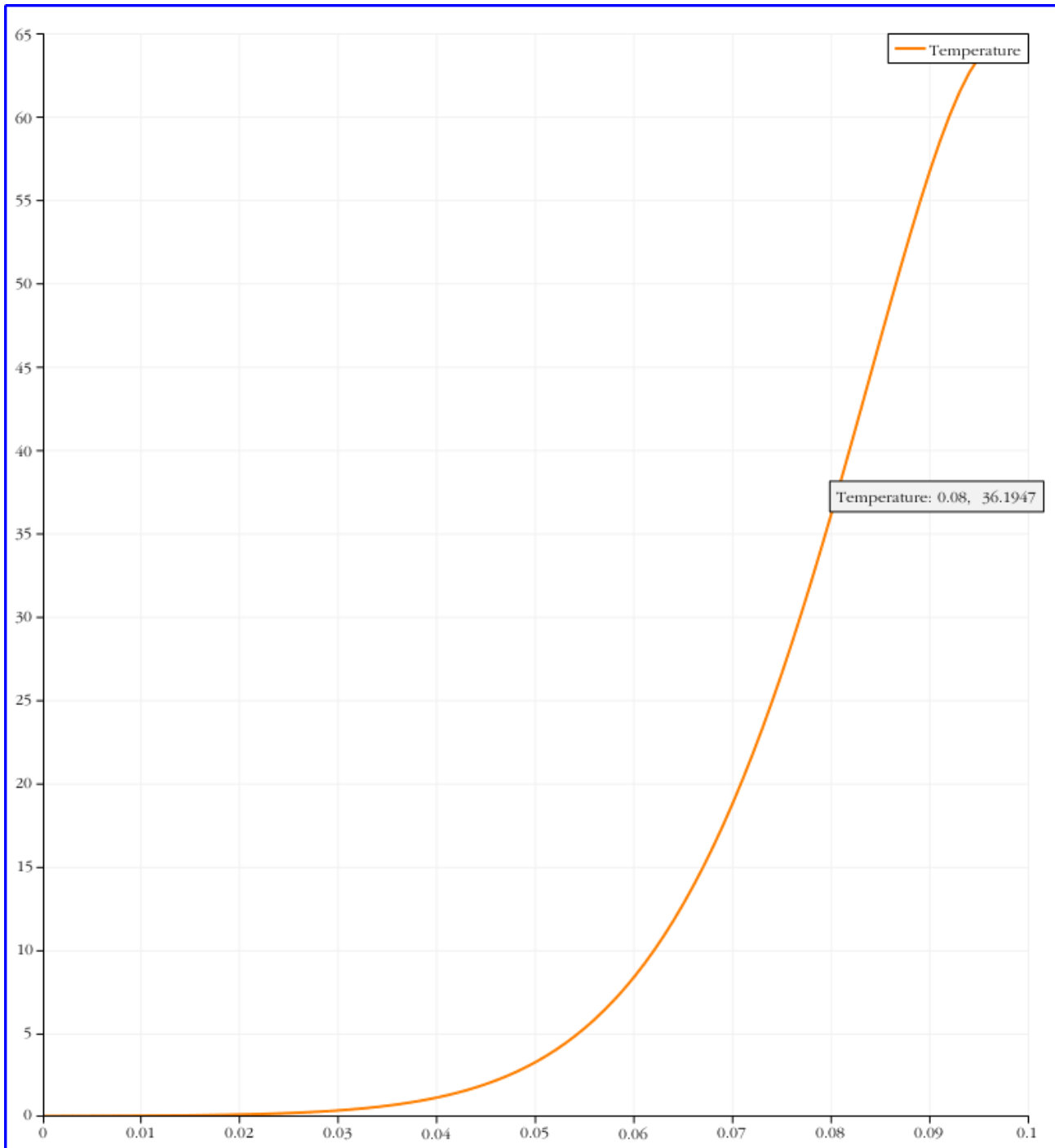

The difference between the obtained value 36.6617 and the required one 36.60 is 0.17%..

7. Download numerical data.

Select **File** → **Save Data** in the Main Menu or click **Ctrl+S**. Enter the file name (*.csv format), leave it by default. Click **OK**. The saved file is an ordinary table of numerical data which can be opened in any text editor.

Using Console Interface

For geometry generation, meshing, setting boundary conditions and materials you can use Console Interface. The following program code allows performing the steps of the above-described guide, you only need to **manually specify the full path and name of the file to be saved**.

```
reset
brick x 0.1 y 0.01 z 0.01
move Volume 1 x 0.05 include_merged
volume 1 scheme polyhedron
volume 1 size 0.001
mesh volume 1
create material 1
modify material 1 name 'Material 1'
modify material 1 set property 'DENSITY' value 7200
modify material 1 set property 'ISO_CONDUCTIVITY' value 35
modify material 1 set property 'SPECIFIC_HEAT' value 440.5
block 1 add volume 1
block 1 material 1
block 1 element solid
create temperature on surface 4 value 1
create temperature on surface 6 value 1
bcdep temperature 2 value '100*sin(0.0785*t)'
analysis type dynamic heattrans dim3 preload on
dynamic method full_solution scheme implicit maxtime 32 steps 100 newmark_gamma
0.0050.005calculation start path "D:/Fidesys/test.pvd"
```



It is also possible to run the file *Example_14_Dynamic_3D_Conduction_Spectr.jou*, by selecting Journal Editor on Toolbar. In a pop-up window of the main menu select **File** → **Open** and open the necessary journal file.

Harmonic analysis (beam model)

An example with a beam construction is considered. Specified structural damping.

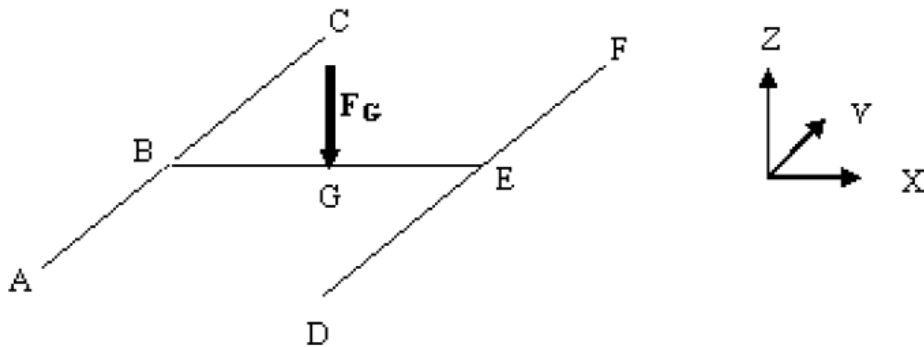

The model is rigidly fixed at points A, D, C, F. A force dependent on frequency is applied to the middle of the BE face. The sides of the structure have the same length: $AB = BC = DE = EF = BG = EG = 2.5$ m. Material parameters: Young's modulus $E = 2e11$ Pa, Poisson's ratio $\nu = 0.3$, density $\rho = 7800$ kg / m³. Specified structural damping 0.1.

Geometry creating

1. Create a structure and beams (lines).

Since the structure contains edges of the same length, use the parameter $L = 2.5$. To set a parameter, enter in the command line # $\{L = 2.5\}$.

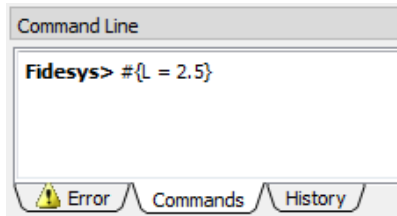

On the toolbar, select a line creating mode (Mode - **Geometry**, Entity - **Curve**, Action - **Create**). From the drop-down list, select **Line**. On the **Build** panel, use select **Position and Direction**. Next, enter the necessary data to create the first line:

- Location: 0 0 0 (space separated);
- Direction: 0 1 0;
- Length: $\{L\}$.

Click **Apply**.

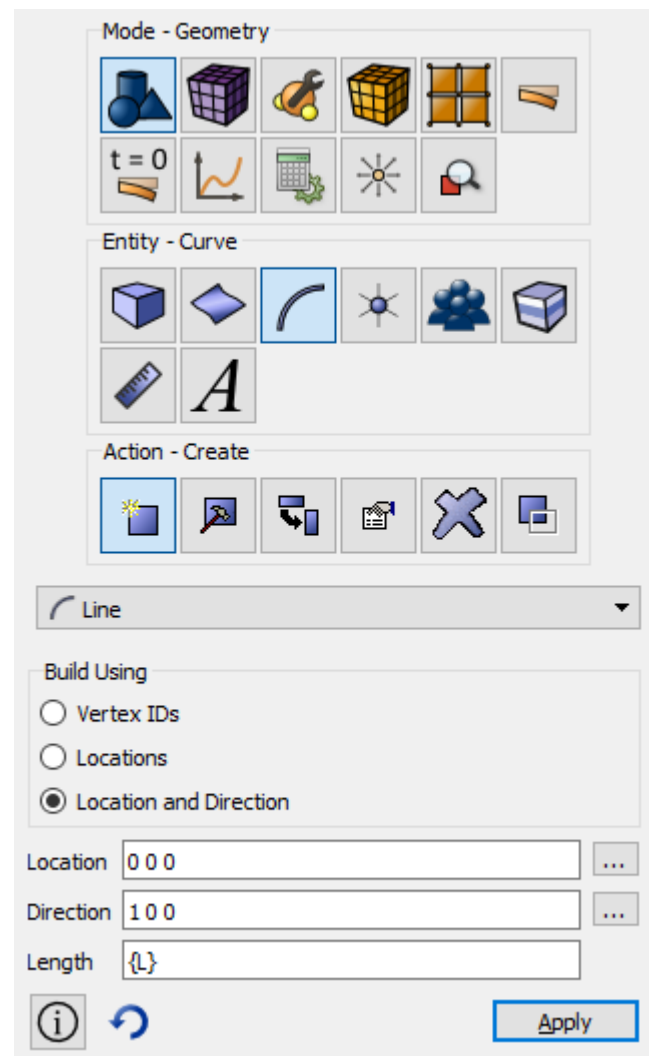



Specify the necessary data to create a second line:

- Location: $0 \{L\} 0$;
- Direction: $0 \ 1 \ 0$;
- Length: $\{L\}$.

Location	<input type="text" value="0 {L} 0"/>	...
Direction	<input type="text" value="0 1 0"/>	...
Length	<input type="text" value="{L}"/>	

Click **Apply**.

Specify the necessary data to create a third line:

- Location: $0 \{L\} 0$;
- Direction: $1 \ 0 \ 0$;
- Length: $\{L\}$.

Location	<input type="text" value="0 {L} 0"/>	...
Direction	<input type="text" value="1 0 0"/>	...
Length	<input type="text" value="{L}"/>	

Click **Apply**.

Specify the necessary data to create the fourth line:

- Location: $\{L\} \{L\} 0$;
- Direction: $1 \ 0 \ 0$;
- Length: $\{L\}$.

Location	<input type="text" value="{L} {L} 0"/>	...
Direction	<input type="text" value="1 0 0"/>	...
Length	<input type="text" value="{L}"/>	

Click **Apply**.

Specify the necessary data to create a fifth line:

- Location: $\{2 * L\} 0 \ 0$;
- Direction: $0 \ 1 \ 0$;
- Length: $\{L\}$.

Location	<input type="text" value="{2*L} 0 0"/>	...
Direction	<input type="text" value="0 1 0"/>	...
Length	<input type="text" value="{L}"/>	

Click **Apply**.

Specify the necessary data to create the sixth line:

- Location: $\{2 * L\} \{L\} 0$;
- Direction: $0 \ 1 \ 0$;
- Length: $\{L\}$.

Location	<input type="text" value="{2*L} {L} 0"/>	...
Direction	<input type="text" value="0 1 0"/>	...
Length	<input type="text" value="{L}"/>	

Click **Apply**.



Splicing tops on received beams. On the toolbar, select the vertex creating mode (Mode - **Geometry**, Entity - **Vertex**, Action - **Merge**). Specify:

- Vertex ID: all.

Click **Apply**.

Beam structures was created

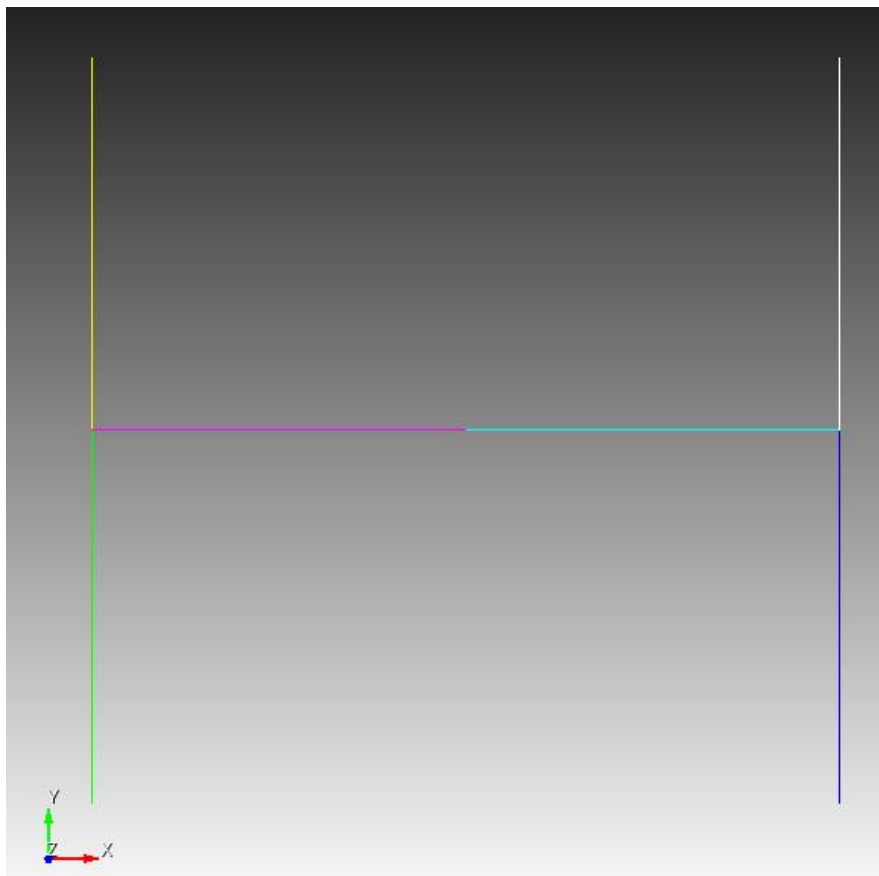

Meshing

- On the command panel, select the volume mesh mode (Mode - **Mesh**, Entity - **Curve**, Action - **Mesh**). Specify the following parameters:
 - Select curves: all;
 - Settings for curve: Equal;
 - Approximate size: 0.1.

Click **Apply Size**.

Click **Mesh**.

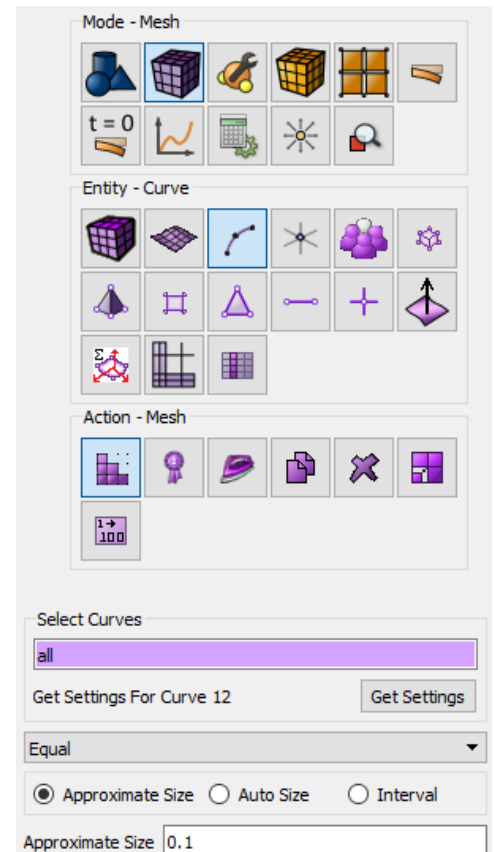

Specifying the material and type of element

- Create a material.

Select setting the material properties section on Command Panel (Mode — **Material**, Entity — **Materials management**).

In the Materials Management window that opens, in the second column, click on the caption Enter the name of the material and write "Material 1". Press the ENTER key.

In the left column, select Elasticity - Hooke Material. Select with the mouse the characteristic Young's modulus. Hold down the left mouse button and drag the label to Material Properties. Double-click in the Value field next to Young's modulus and enter the number 2e11. Similarly, from the Hooke Material section add the Poisson Ratio 0.3, Density: 7800.

Click **Apply**.

Close the window.

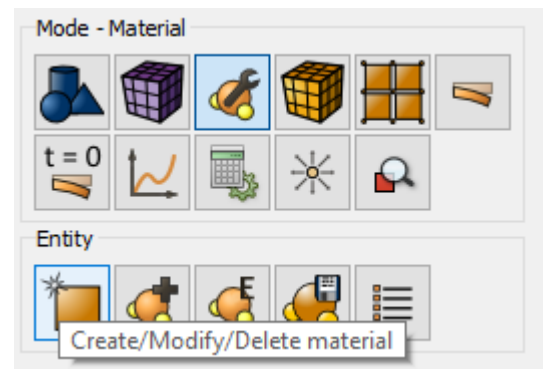

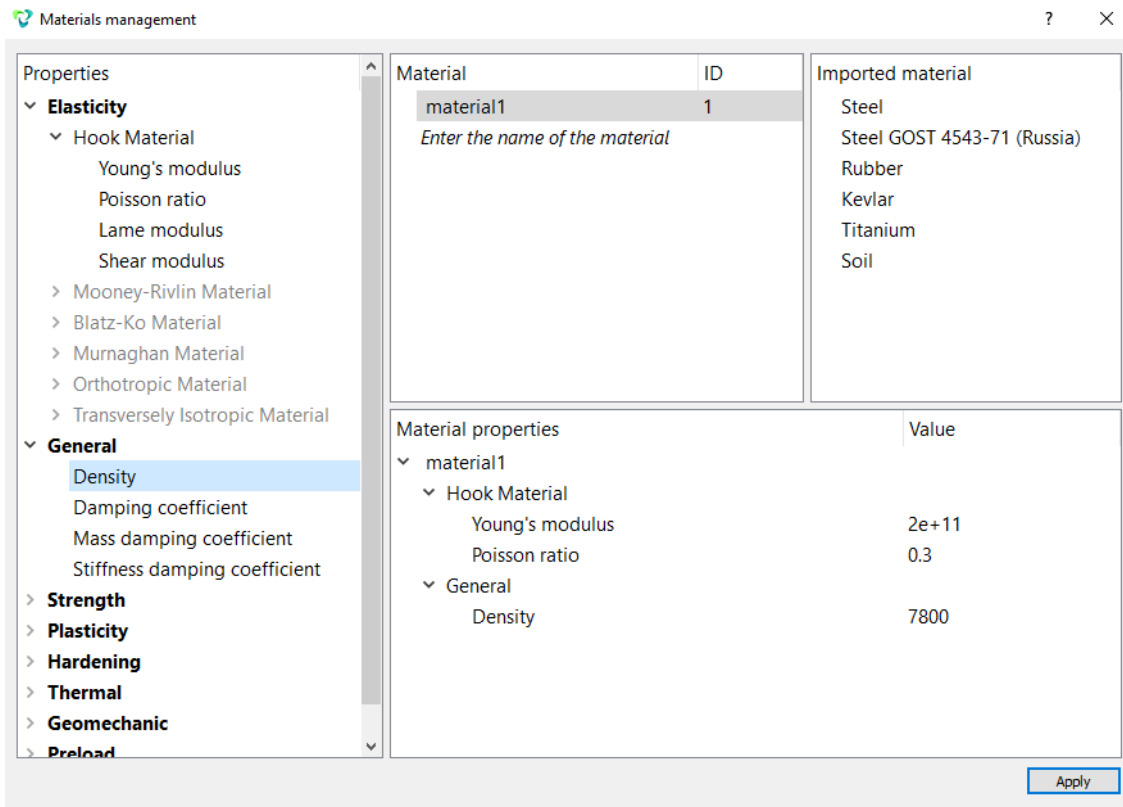

2. Create a block of the one type of material.

On the command panel, select the mode for setting material properties (Mode - **Blocks**, Entity - **Block**, Action - **Add**). Set the following parameters:

- Block ID: 1;
- Entity list: Curve;
- Entity ID (s): all.

Click **Apply**.

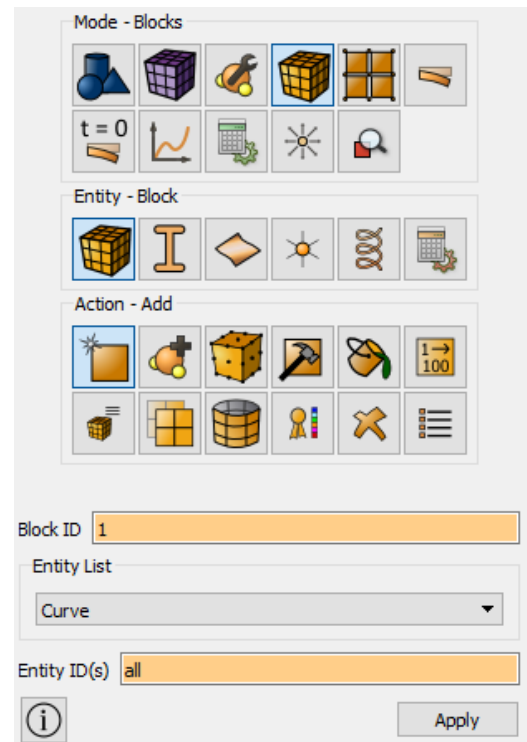

3. Assign the material to the block.

On the command panel, select the mode for setting material properties (Mode - **Blocks**, Entity - **Block**, Action - **Set Material**). Set the following parameters:

- Block ID (s): 1;
- Available materials: Material 1.

Click **Apply**.

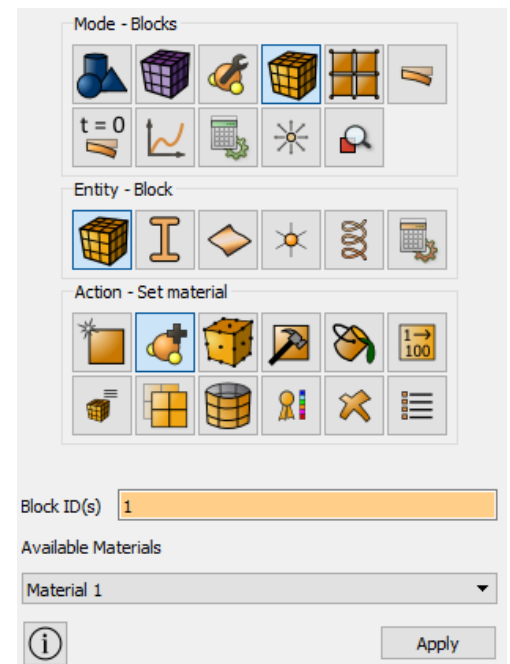

4. Assign an item type.

On the command panel, select the mode for setting material properties (Mode - **Blocks**, Entity - **Block**, Action - **Element types**). Set the following parameters:

- Block ID (s): 1 or all;
- Category: Beam;
- Order: 1.

Click **Apply**.

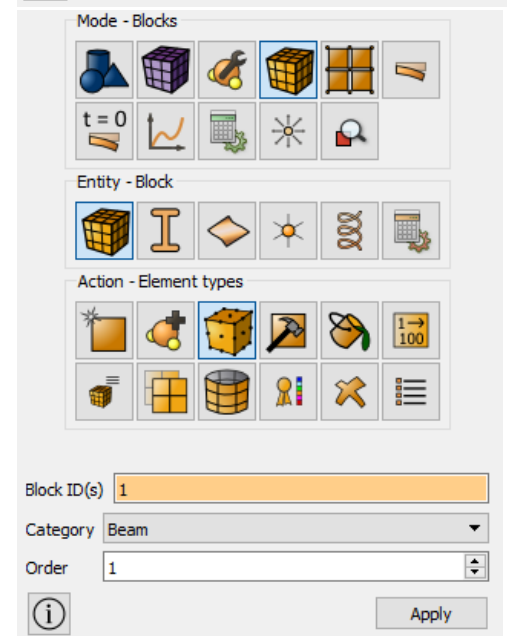

Beam section setting

1. Specify the section of the beams. On the command panel, select setting material properties mode (Mode - **Blocks**, Entity - **Beam Properties**). Set the following parameters:

- Block ID: 1;
- CS rotation angle: 0;
- Calculate relative to: Centroid;
- Select profile: Ellipse;
- Minor axis (b): 0.1;
- Major axis (a): 0.1.

Click **Apply**.

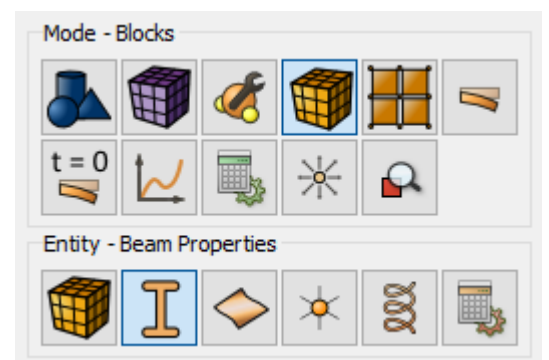

Setting boundary conditions

1. Fix the vertices A, D, C, F through all displacements and rotations.

On the command panel, select Mode - **Boundary Conditions**, Entity - **Displacement**, Action - **Create**. Set the following parameters:

- System assignment ID;
- Entity list: Vertex;
- Entity ID(s): 1 4 9 12 (or select the vertices with the mouse by pressing the Ctrl key);
- Degrees of freedom: All;
- DOF Value: 0 (can not fill).

Click **Apply**.

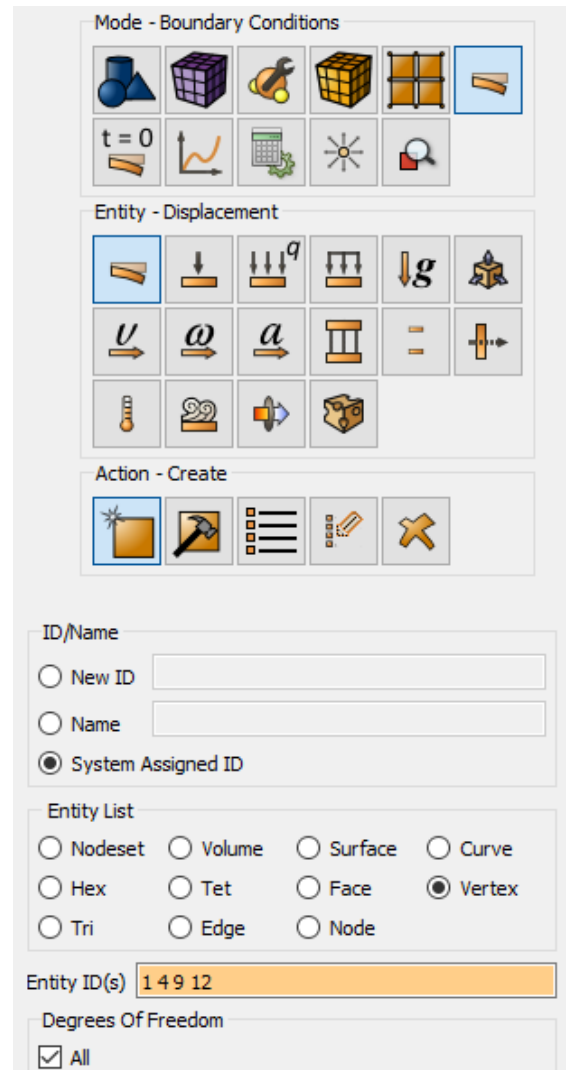

2. Apply a force dependent on frequency.

On the command panel, select Mode - **Boundary Conditions**, Entity - **Force**, Action - **Create**. Set the following parameters:

- System assignment ID;
- Force Entity list: Vertex;
- Entity ID(s): 6 (or select a vertex with the mouse, as shown in the figure);
- Force: 1;
- Direction: 0 0 -1 (negative direction along the z axis).

Click **Apply**

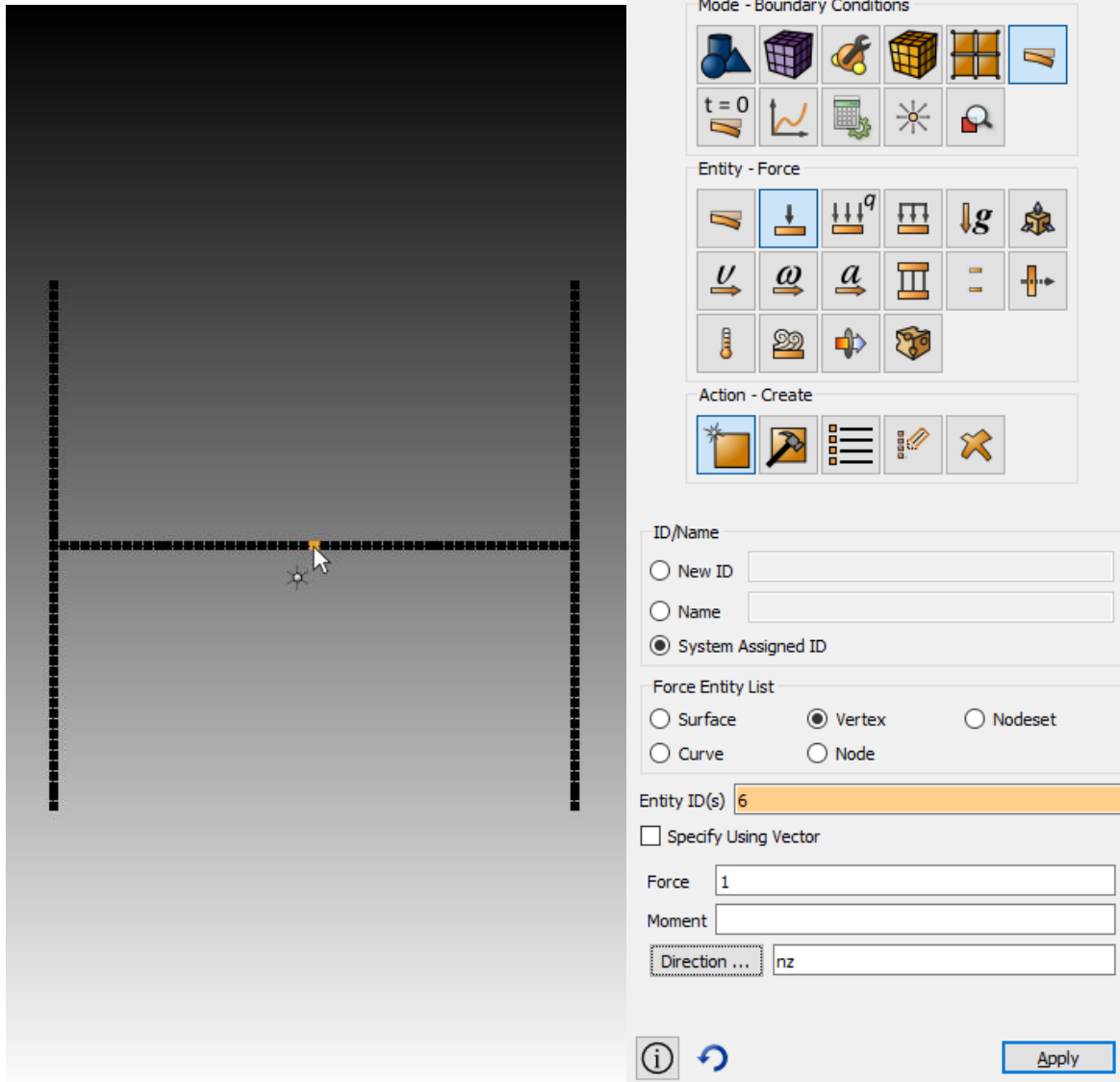

3. Set the frequency dependence.

On the command panel, select Mode - **BC Dependency**. In the BC Dependency window that appears, select the boundary condition Force 1 in the left column, in the Formula panel from the drop-down list, select Harmonic. Enter the following data:

- Amplitude: 1e5;
- Phase: 0.

Click **Apply**

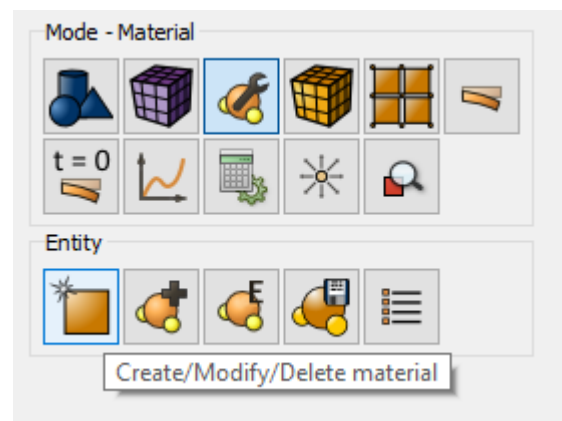

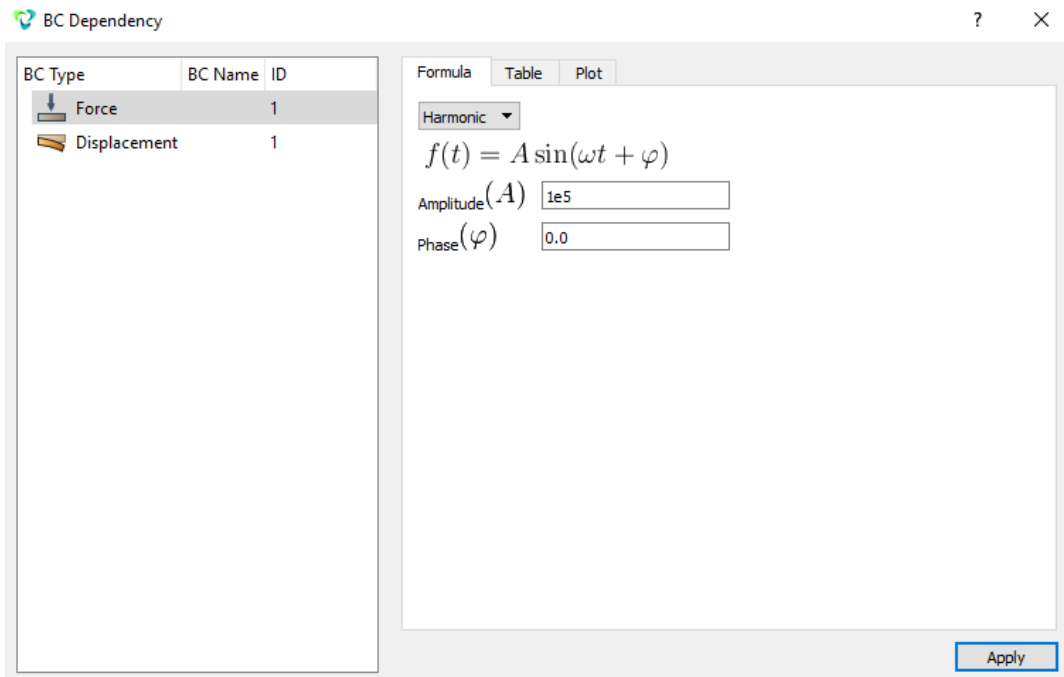

Run calculation

1. Set the type of problem you want to solve.

On the command panel, select the calculation settings module (Mode - **Calculation Settings**, Calculation Settings - **Harmonic - General**). Set the following calculation parameters:

- Dimension: 3D;
- Method: Mod superposition;
- Maximum frequency number: 10;
- Frequency Interval: 0-200;
- Frequency step: 0.5;

Click **Apply**.

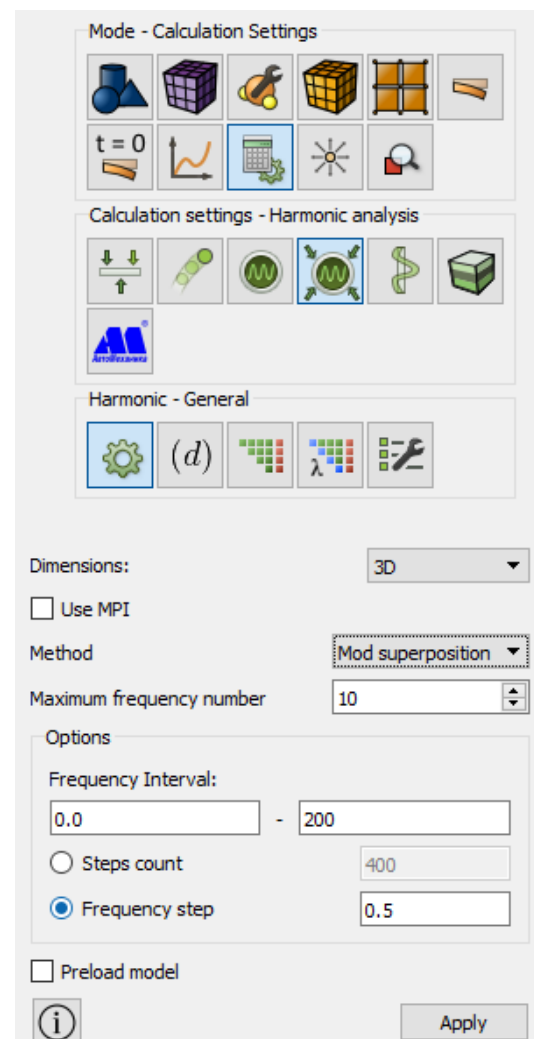

2. Specify structural damping.

On the command panel, select the calculation settings module (Mode - **Calculation Settings**, Calculation Settings - **Harmonic - Damping**). Set the following calculation parameters:

- Structural damping: 0.1.

Click **Apply**.

Click **Start calculation**.

3. In the window that appears, select the directory in which the result will be stored, and enter the file name.
4. In the case of a successful calculation, the console displays the message: "*Calculation finished successfully at <date> <time>*".

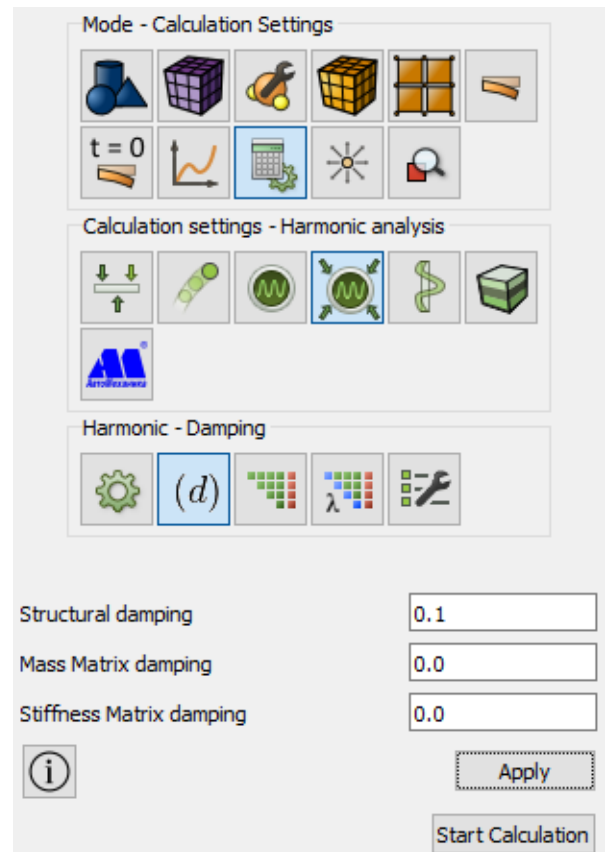

Results analysis

1. Compare the results displayed on the command line with the results below:

```

Command Line
Calculation started at 2019-02-17 15:18:29
Using 4 CPU cores of 4 available - HPC Local (Standard) is installed.
FidesysCalc parse fc done
EIGENFREQUENCY
Number Eigenfrequency
1 8.902470 Hz
2 11.913360 Hz
3 14.771100 Hz
4 14.839233 Hz
5 19.833076 Hz
6 39.345251 Hz
7 40.046269 Hz
8 49.535474 Hz
9 50.825364 Hz
10 54.184752 Hz
    
```

2. Open the file with the results.

This can be done in two ways:

- Press Ctrl + E.
- From the main menu, select **Results**. Click **Open Last Result**.

The **Fidesys Viewer** window will appear, in which you can view the calculation results.

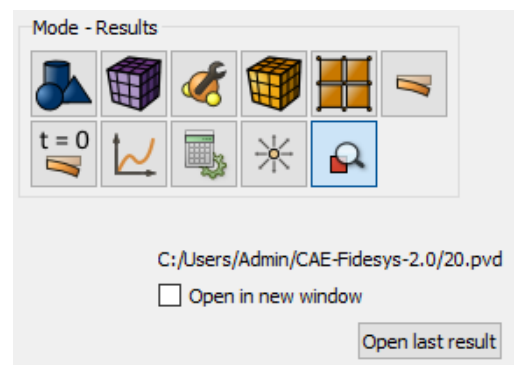

3. In the standard line, select **Filters -> Alphabetical > Harmonic Analysis**.

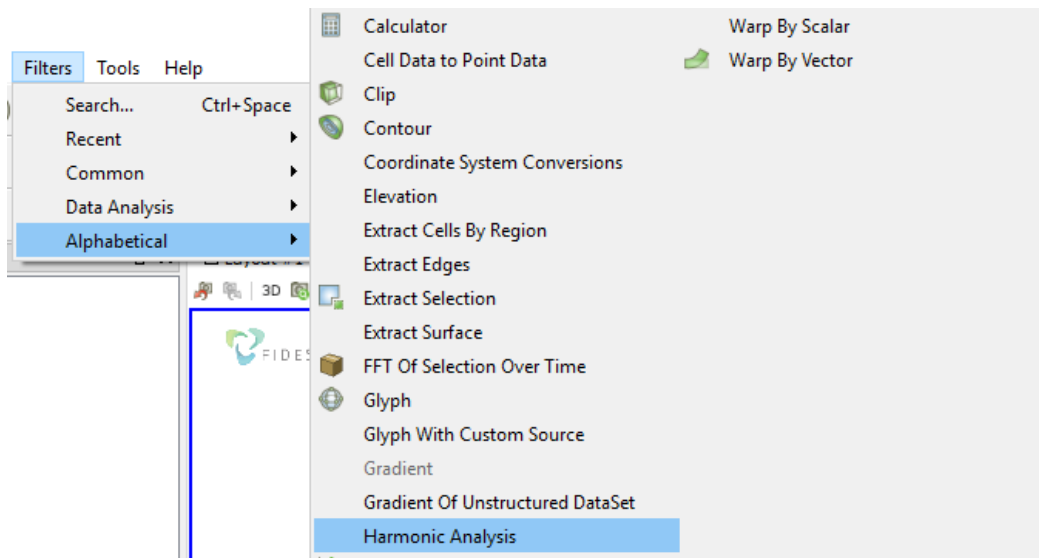

The plot of Displacement (Amplitude) versus frequency must be plotted for node 2 (coincides with vertex B). For the Harmonic analysis filter in the Tree, in the Properties tab, specify:

- Node ID: 2.

Click **Apply**.

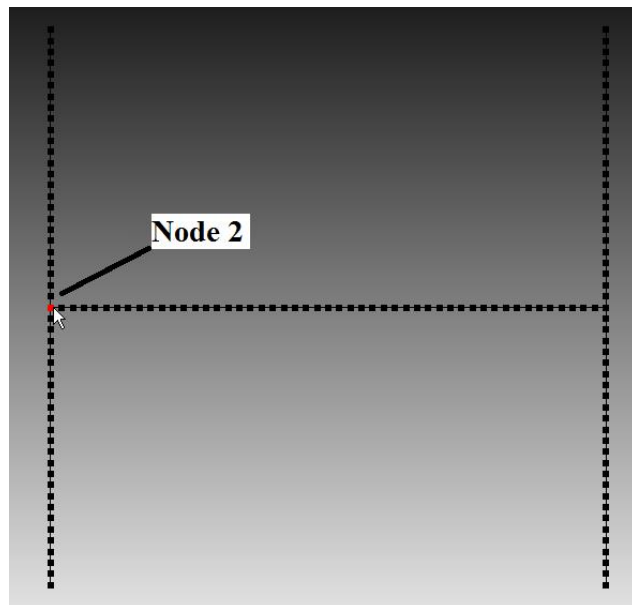
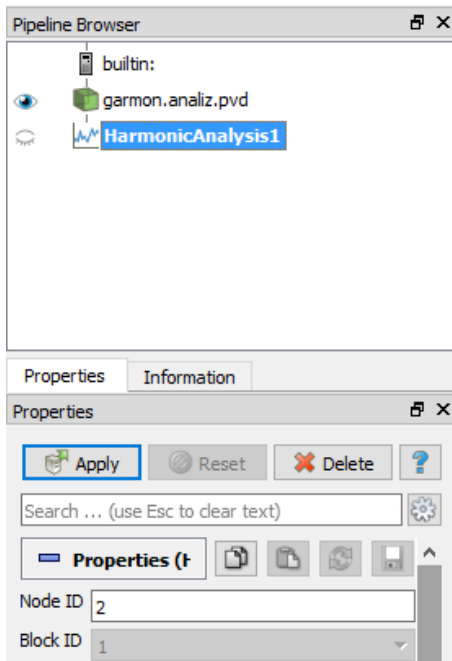

In the section Row Parameters for the X-axis that appears, select only the Displacement Amplitude Z (Harmonic Analysis).



The Pipeline Browser shows a tree structure with 'builtin:' at the top, followed by 'garmon.analiz.pvd', and 'HarmonicAnalysis 1' selected. Below it, the Properties panel is open to the 'Information' tab. It features buttons for 'Apply', 'Reset', 'Delete', and a help icon. A search bar is present. Under 'Display (XYChart)', there are icons for 'Composite Data Set Index', 'Multi-block Dataset', and 'Harmonic Analysis', all of which are checked. The 'Attribute Type' is set to 'Point Data'. Under 'X Axis Parameters', 'Use Index For XAxis' is unchecked, and the 'X Array Name' is 'Frequency'.

The Series Parameters panel is open, showing a list of variables. The 'Variable' column is visible. The 'Displacement Amplitude Z (Harmonic Analysis)' variable is checked, while all other variables are unchecked.

Variable
<input type="checkbox"/> Acceleration Amplitude X (Harmonic Analysis)
<input type="checkbox"/> Acceleration Amplitude Y (Harmonic Analysis)
<input type="checkbox"/> Acceleration Amplitude Z (Harmonic Analysis)
<input type="checkbox"/> Acceleration Phase X (Harmonic Analysis)
<input type="checkbox"/> Acceleration Phase Y (Harmonic Analysis)
<input type="checkbox"/> Acceleration Phase Z (Harmonic Analysis)
<input type="checkbox"/> Acceleration Rotation Amplitude X (Harmonic Analysis)
<input type="checkbox"/> Acceleration Rotation Amplitude Y (Harmonic Analysis)
<input type="checkbox"/> Acceleration Rotation Amplitude Z (Harmonic Analysis)
<input type="checkbox"/> Acceleration Rotation Phase X (Harmonic Analysis)
<input type="checkbox"/> Acceleration Rotation Phase Y (Harmonic Analysis)
<input type="checkbox"/> Acceleration Rotation Phase Z (Harmonic Analysis)
<input type="checkbox"/> Displacement Amplitude X (Harmonic Analysis)
<input type="checkbox"/> Displacement Amplitude Y (Harmonic Analysis)
<input checked="" type="checkbox"/> Displacement Amplitude Z (Harmonic Analysis)

On the right side of the screen received the desired graph.

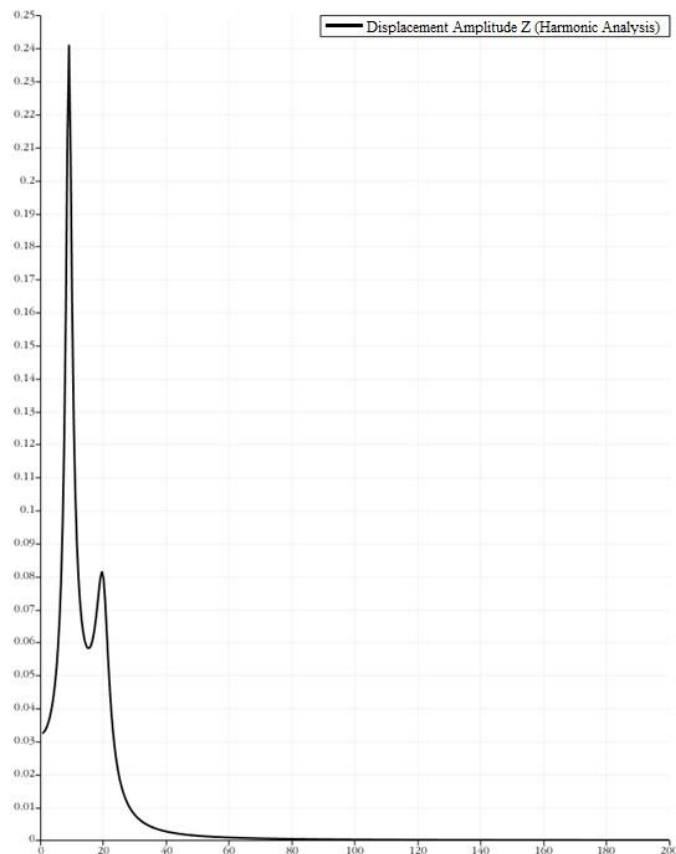

Hover over one of the peaks, then the pop-up text will display the amplitude value corresponding to the frequency.

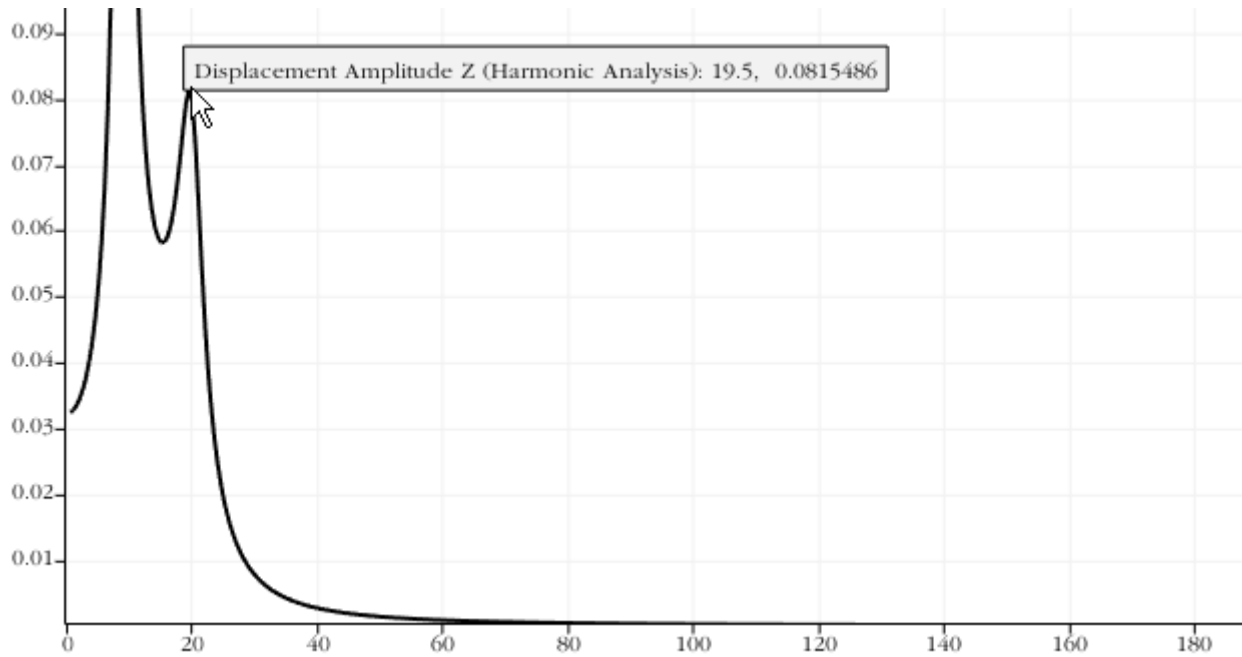

Using the console interface

Geometry generation, mesh generation, setting boundary conditions and materials can be performed using the console interface. Below is the program code that allows you to perform the steps of the above manual, you only need to **specify the full path and name of the saved file**.

```

reset
#{L=2.5}
create curve location 0 0 0 direction 0 1 0 length {L} #1
create curve location 0 {L} 0 direction 0 1 0 length {L} #2
create curve location 0 {L} 0 direction 1 0 0 length {L} #3
create curve location {L} {L} 0 direction 1 0 0 length {L} #4
create curve location {2*L} 0 0 direction 0 1 0 length {L} #5
create curve location {2*L} {L} 0 direction 0 1 0 length {L} #6
merge all
curve all size 0.1
curve all scheme equal
mesh curve all
create material 1
modify material 1 name "material1"
modify material 1 set property 'DENSITY' value 7800
modify material 1 set property 'POISSON' value 0.3
modify material 1 set property 'MODULUS' value 2e+11
block 1 add curve all
block 1 element beam order 1
block 1 material 'material1'
block 1 attribute count 7
block 1 attribute index 1 value 1 name 'Ellipse'
block 1 attribute index 2 value 0 name 'ey'
block 1 attribute index 3 value 0 name 'ez'
block 1 attribute index 4 value 0 name 'angle'
block 1 attribute index 5 value 1 name 'section_id'
block 1 attribute index 6 value 0.1 name 'geom_b'
block 1 attribute index 7 value 0.1 name 'geom_a'
create displacement on vertex 1 4 9 12 dof all fix
create force on vertex 6 force value 1 direction nz
    
```

```
bcdep force 1 value "harmonic(1e5,0.0, f, time)"
analysis type harmonic elasticity dim3
harmonic method mode_superposition interval from 0 to 200 max_freq_num 10 frequency_step
0.5
damping structural 0.1 mass_matrix 0 stiffness_matrix 0
output nodalforce off record3d off log on vtu on 0.005
calculation start path "D:/Fidesys/test.pvd"
```



You can also run the Example_11_Harmonic_3D_Beam.jou file by selecting the journal editor on the toolbar. In the appeared window in the main menu, select **File** → **Open** and open the required log file.

Bounded Contact Simulation

An example of the calculation of a structure consisting of several volumes that are not merged with each other is considered. There is a geometric gap between the two volumes, so instead of “gluing” the volumes, the bounded contact will be used. The model represents a quarter of the original part.

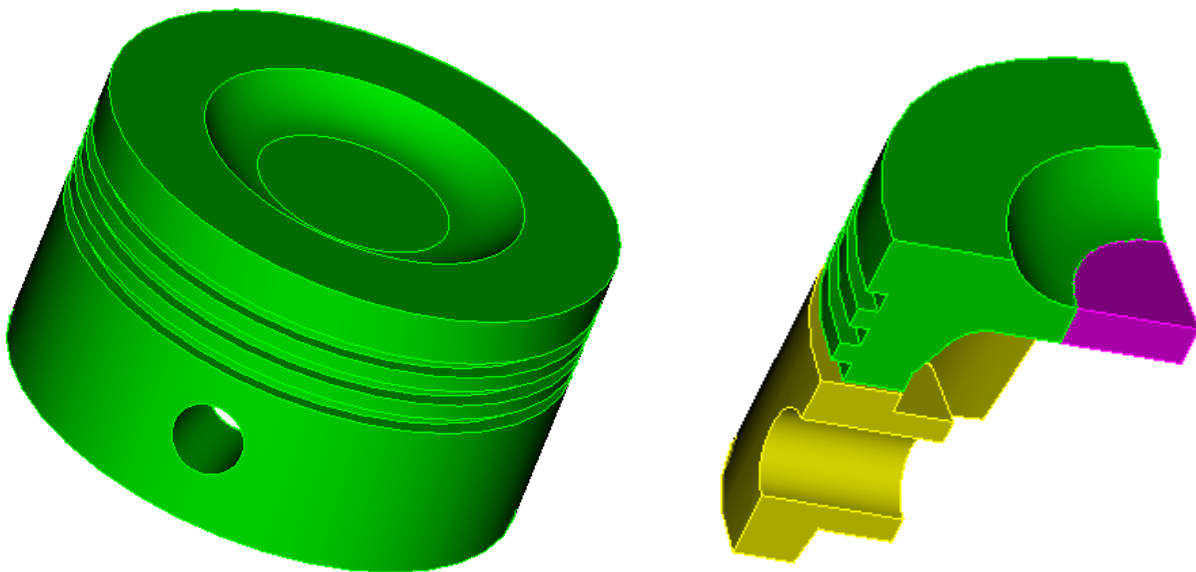

The model is fixed on the lateral faces of the symmetry conditions. The inner surface of the hole is fixed in all degrees of freedom. A pressure of 1 MPa is applied to the upper face of the part. Material parameters: Young's modulus $E = 2e11$ Pa, Poisson's ratio $\nu = 0.3$.

Geometry creation

1. Import geometry

In the standard line select Menu - File - Import. Specify the path to the `Geom_example_contact.stp` file. In the window that appears, click Finish with all the default values of settings.

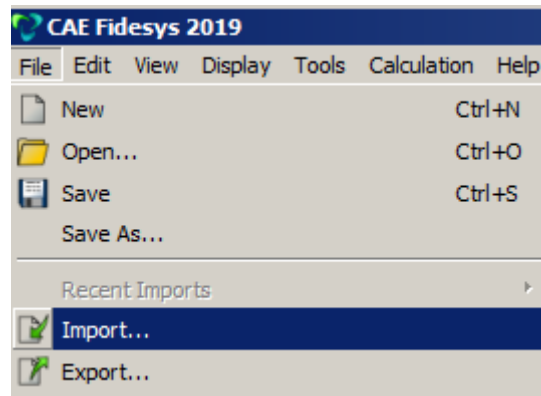

In the Tree on the left you can see three volumes into which the model is separated. All three volumes have no common surfaces.

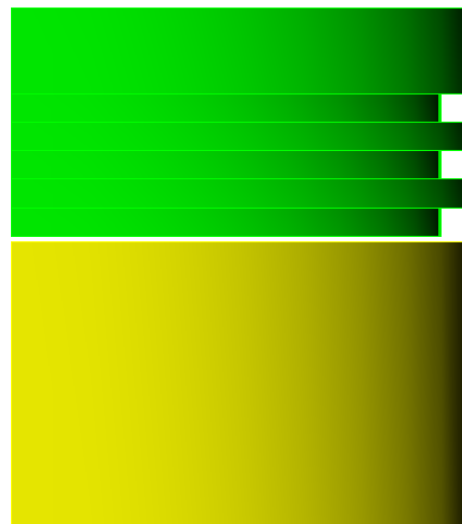
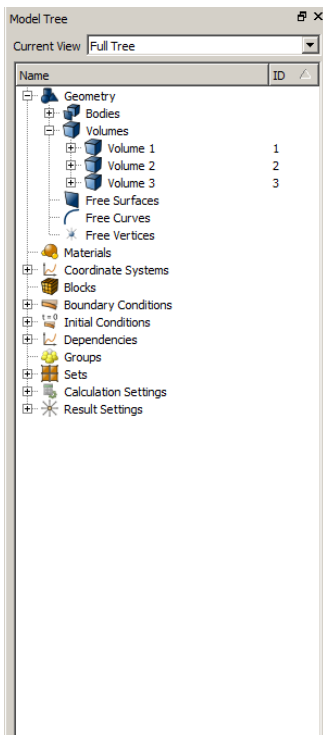

Meshing

1. On the command panel, select the volume mesh mode (Mode - Mesh, Entity - Volume, Action - Intervals). Specify the following parameters:

- In the drop-down list, select: Approximate size;
- Choice of volumes: 1;
- Approximate size: 0.1.

Click **Apply Size**. Click **Mesh**.

2. On the command bar, select the volume mesh building mode (Mode - **Mesh**, Entity - **Volume**, Action - **Intervals**). Specify the following parameters:

- In the drop-down list, select: Approximate size;
- Select volumes: 2;
- Approximate size: 0.3.

Click **Apply Size**.

Click **Mesh**.

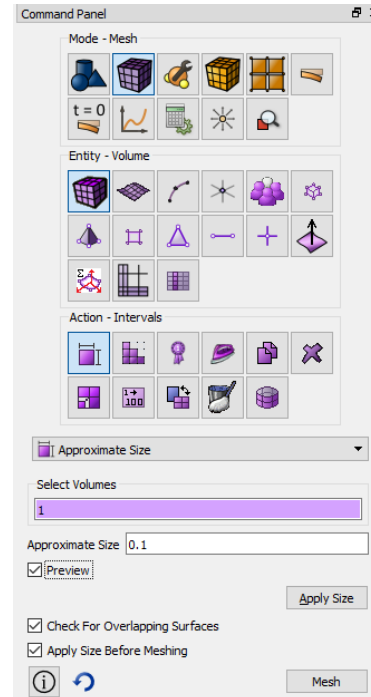
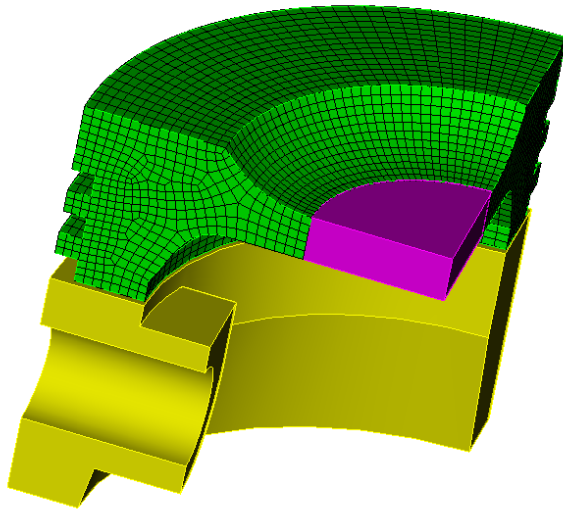

3. On the command panel, select the volume mesh creating mode (Mode - **Mesh**, Entity - **Volume**, Action - **Intervals**). Specify the following parameters:

- In the drop-down list, select: Approximate size;
- Select volumes: 2;
- Approximate size: 0.3.

Click **Apply Size**.

Click **Mesh**.

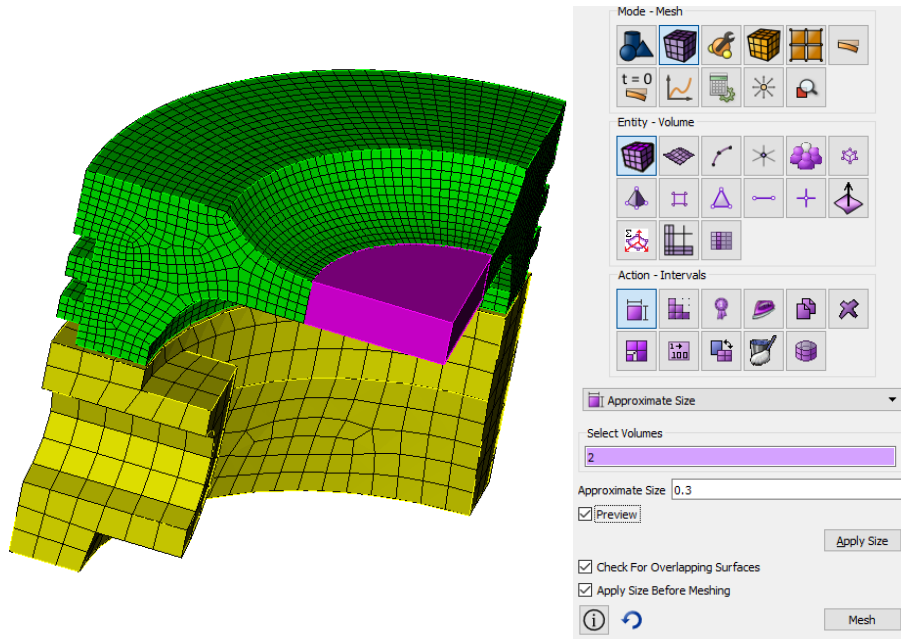

Thus, a non-conformal finite element mesh was created on the model.

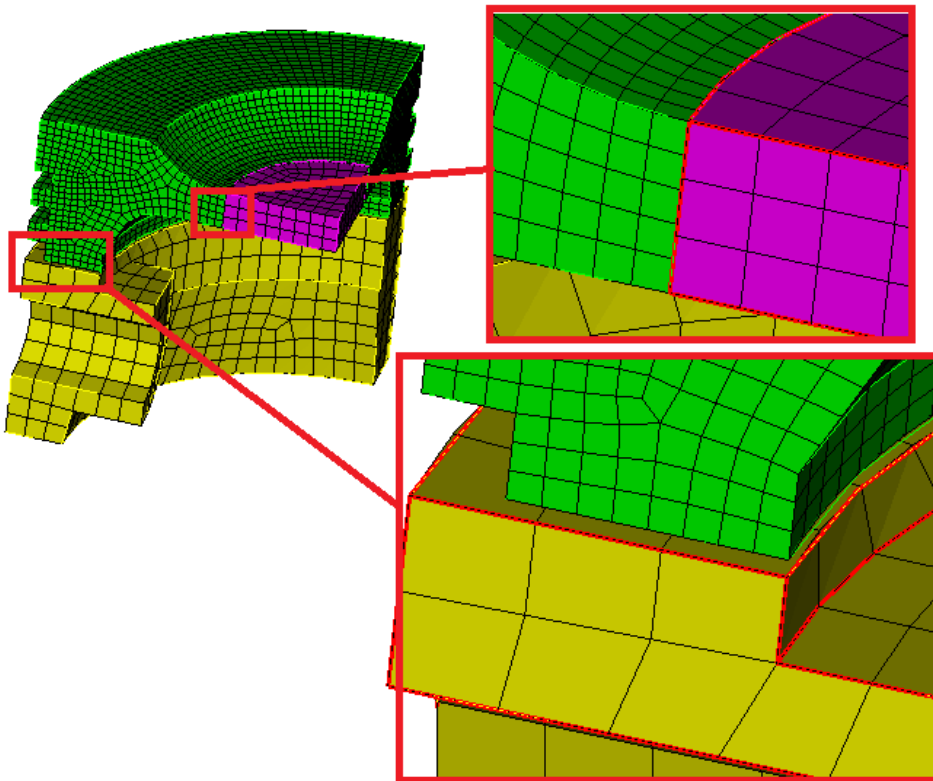

Specifying the material and type of element

1. Create a material.

Select setting the material properties section on Command Panel (Mode — **Material**, Entity — **Materials management**).

In the Materials Management window that opens, in the second column, click on the caption Enter the name of the material and write "Material 1". Press the ENTER key.

In the left column, select Elasticity - Hooke Material. Select with the mouse the characteristic Young's modulus. Hold down the left mouse button and drag the label to Material Properties. Double-click in the Value field next to Young's modulus and enter the number $2e+11$. Similarly, from the Hooke Material section add the Poisson Ratio 0.3

Click **Apply**. Close the window.

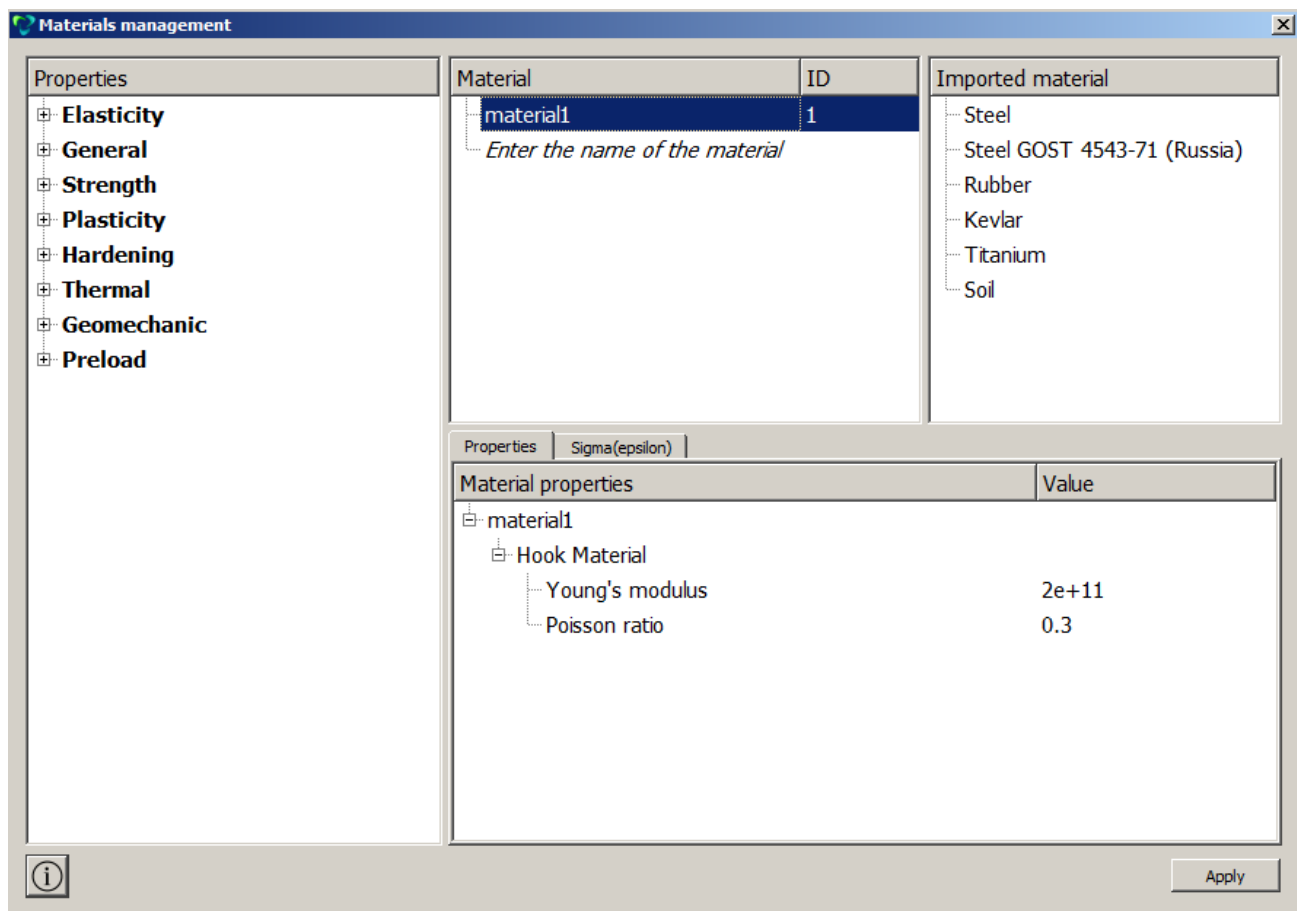
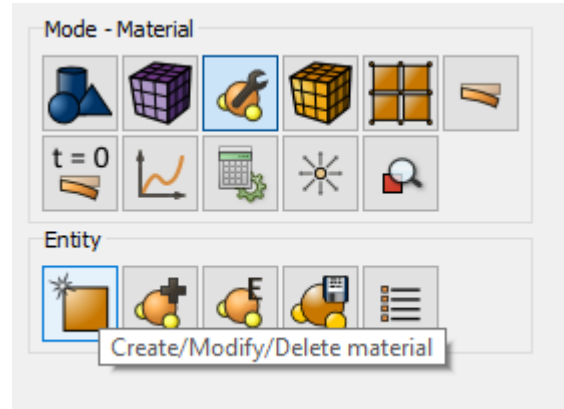

2. Create a block of the one type of material.

On the command panel, select Mode - **Blocks**, Entity - **Block**, Action - **Add**. Set the following parameters:

- Block ID: 1;
- Entity list: Volume;
- Entity ID(s): all.

Click **Apply**.

3. Assign the material to the block.

On the command bar, select Mode - **Blocks**, Entity - **Block**, Action - **Set Material**. Set the following parameters:

- Block ID (s): 1;
- Available materials: material1.

Click **Apply**.

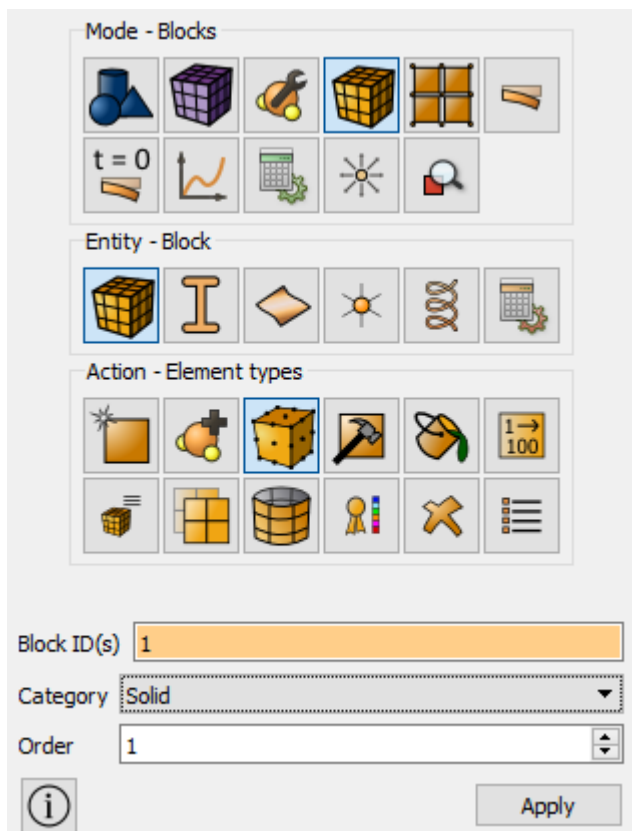
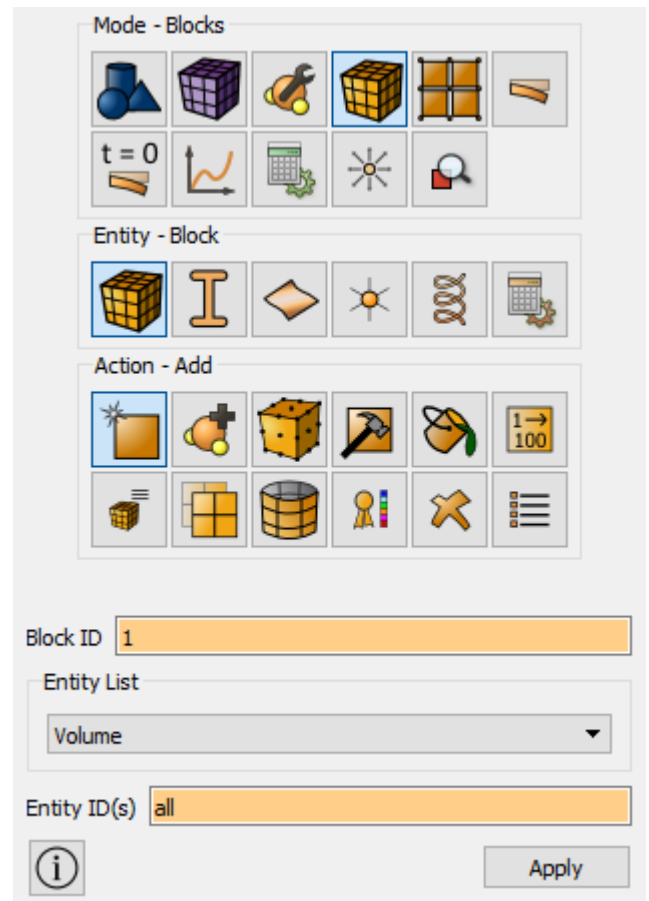

4. Assign an element type.

On the command panel, select the mode for setting material properties (Mode - **Blocks**, Entity - **Block**, Action - **Element types**). Set the following parameters:

- Block ID (s): 1 or all;
- Category: Solid;
- Order: 1.

Click **Apply**.

Setting boundary conditions

1. Fix the sides of the part with the condition of symmetry.

On the command panel, select Mode - **Boundary Conditions**, Entity - **Displacement**, Action - **Create**. Set the following parameters:

- System assignment ID;
- Entity list: Surface;
- Entity ID(s): 2 27 38 (or select the vertices with the mouse while holding down the Ctrl key);
- Degrees of freedom: X-Translation Disp;
- DOF Value: 0 (can not fill).

Click **Apply**.

On the command panel, select Mode - **Boundary Conditions**, Entity - **Displacement**, Action - **Create**. Set the following parameters:

- System assignment ID;
- Entity list: Surface;
- Entity ID(s): 5 22 23 36 (or select the vertices with the mouse by pressing the Ctrl key);
- Degrees of freedom: Z-Translation Disp;
- DOF Value: 0 (can not fill).

Click **Apply**.

2. Fix the hole.

On the command panel, select Mode - **Boundary Conditions**, Entity - **Displacement**, Action - **Create**. Set the following parameters:

- System assignment ID;
- Entity list: surface;
- Entity ID(s): 30 (or select the vertices with the mouse while holding down the Ctrl key);
- Degrees of freedom: All;
- DOF Value: 0 (can not fill).

Click **Apply**.

Mode - Boundary Conditions

Entity - Displacement

Action - Create

ID/Name

New ID

Name

System Assigned ID

Entity List

Nodeset Volume Surface Curve

Hex Tet Face Vertex

Tri Edge Node

Entity ID(s) 2 27 28

Degrees Of Freedom

All

X-Translation Disp X-Rotation Disp

Y-Translation Disp Y-Rotation Disp

Z-Translation Disp Z-Rotation Disp

DOF Value 0

Specify Combination

Overwrite Average

Smallest Largest

3. Apply pressure to the top face.

On the command panel, select Mode - **Boundary conditions**, Entity - **Pressure**, Action - **Create**. Set the following parameters:

- System assignment ID;
- Entity list: surface;
- Entity ID(s): 17 37;
- Magnitude Value: $1e6$ (the exponential type of the number is supported using the Latin letter "e").

Click **Apply**.



4. Set the contact condition.

On the command panel, select Mode - **Boundary Conditions**, Entity - **Contact**, Action - **Create**. Set the following parameters:

- Auto selection;
- Entity List: Global;
- Friction Value: 0;
- Offset: 0.055;
- Type: Tied;
- Method: Auto.

Click **Apply**.

In the Tree on the left, find the **Boundary Conditions - Constraints - Contacts**. Automatically identified two contact pairs.

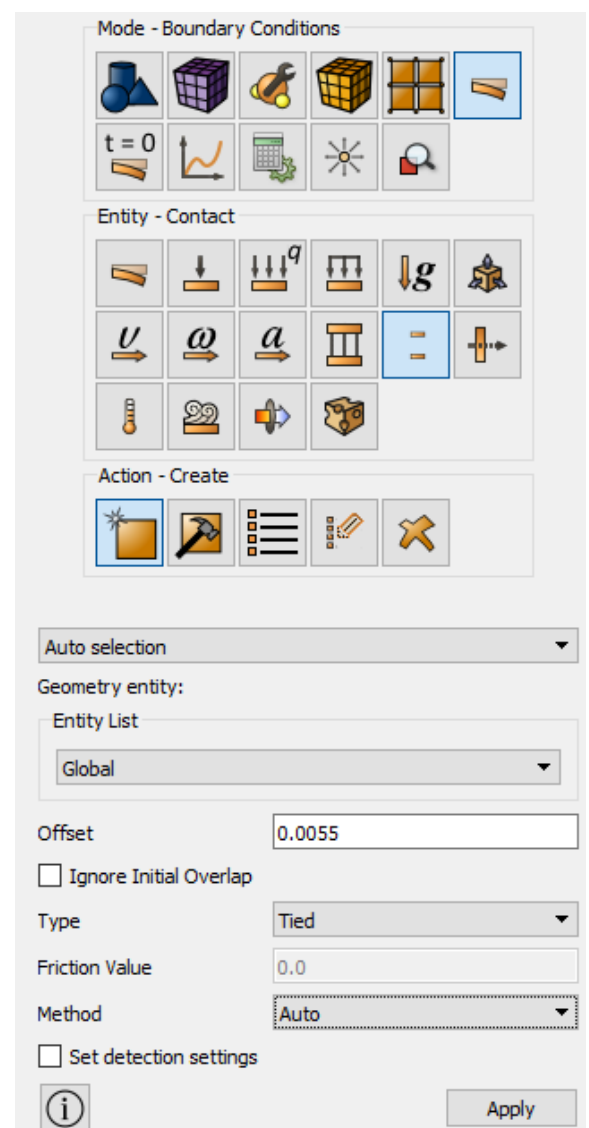

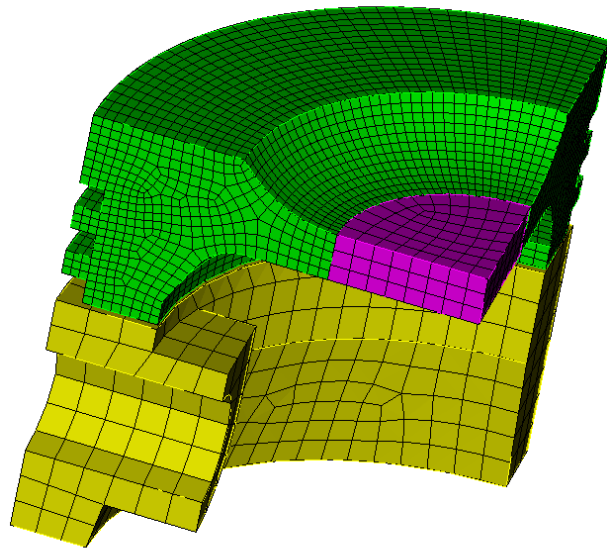
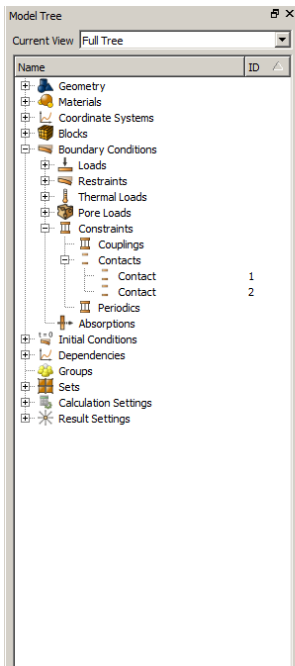

Run calculation

1. Set the type of problem you want to solve.

On the command panel, select the calculation settings mode (Mode - **Calculation Settings - Static - General**). Set the following calculation parameters:

- Dimension: 3D;
- Model: Elasticity.

Click **Apply**.

2. In the window that appears, select the directory in which the result will be saved, and enter the file name.
3. In the case of a successful calculation, the console displays the message: "*Calculation finished successfully at <date> <time>*".

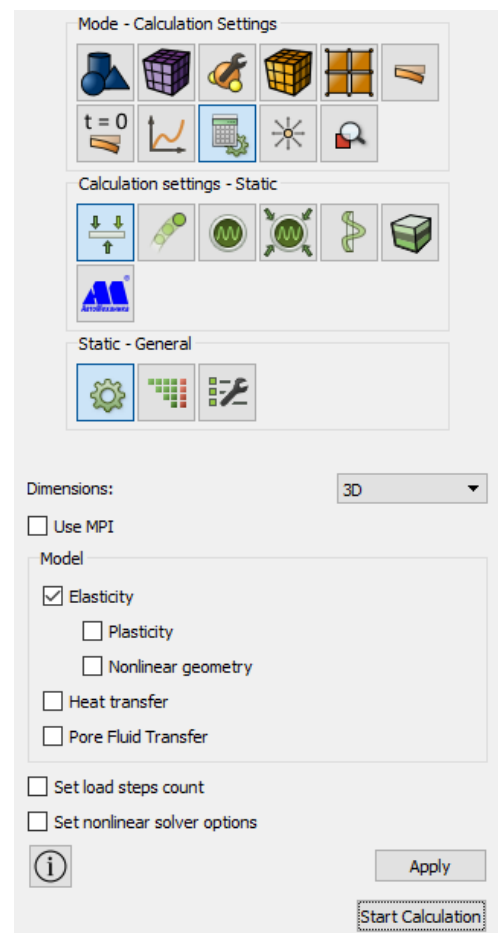

Results analysis

1. Open the results file.

This can be done in two ways:

- Press Ctrl + E.
- From the main menu, select **Results**. Click **Open Last Result**.

The **Fidesys Viewer** window will appear, in which you can view the calculation results.

2. Display the Contact Status Node for the model.

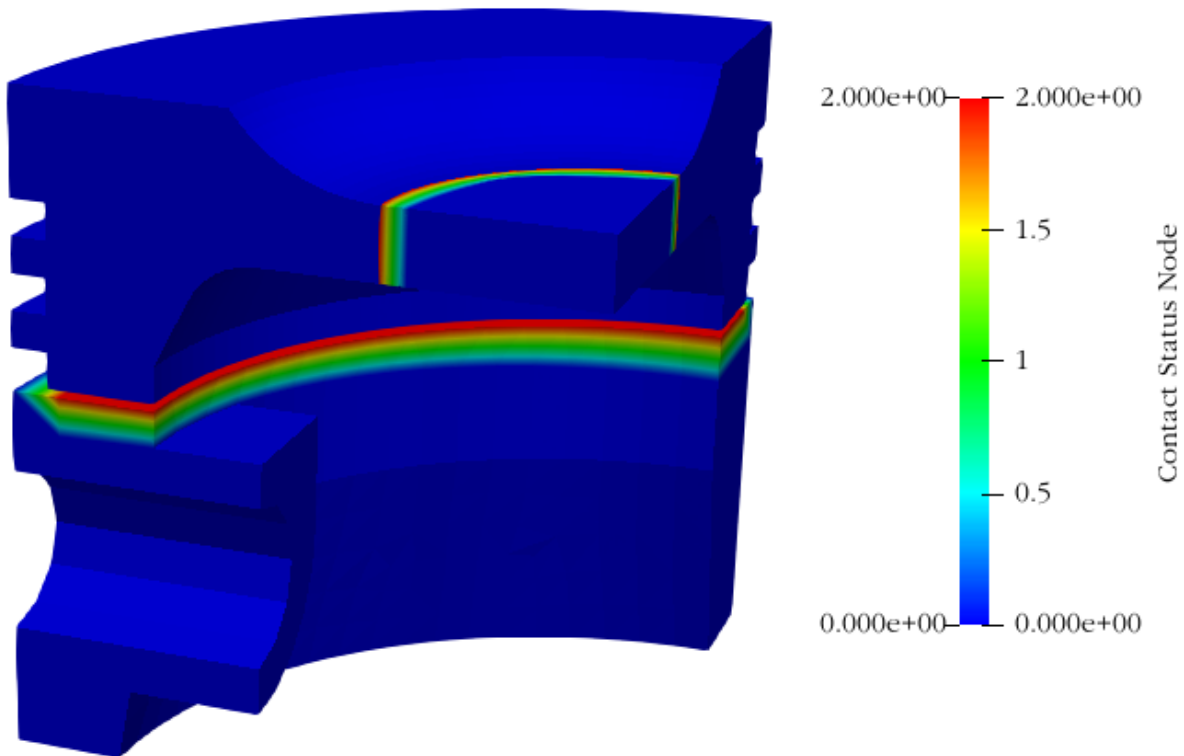
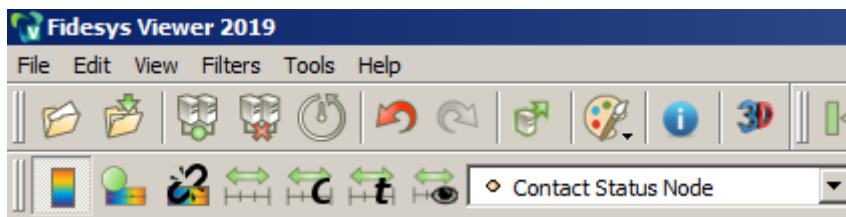
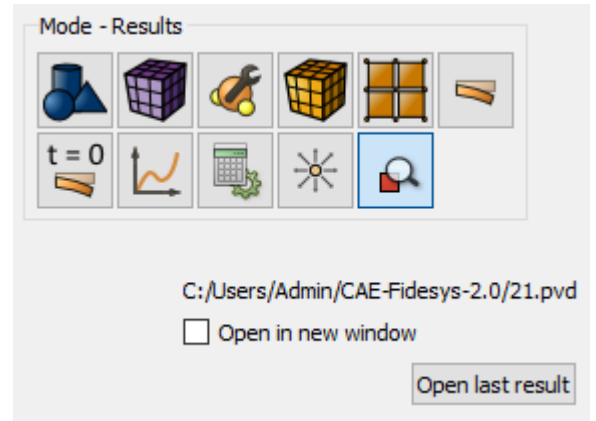

3. Display displacements for the deformed view of the model.

Specify the scale of 2000.

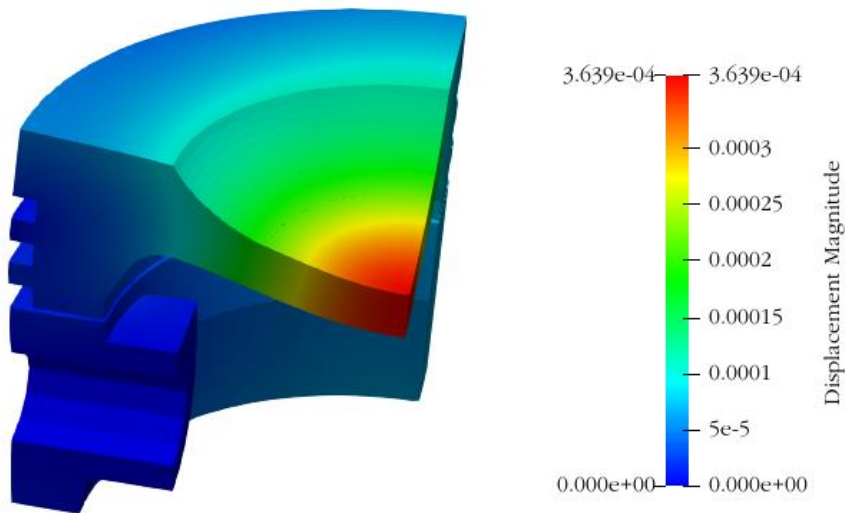
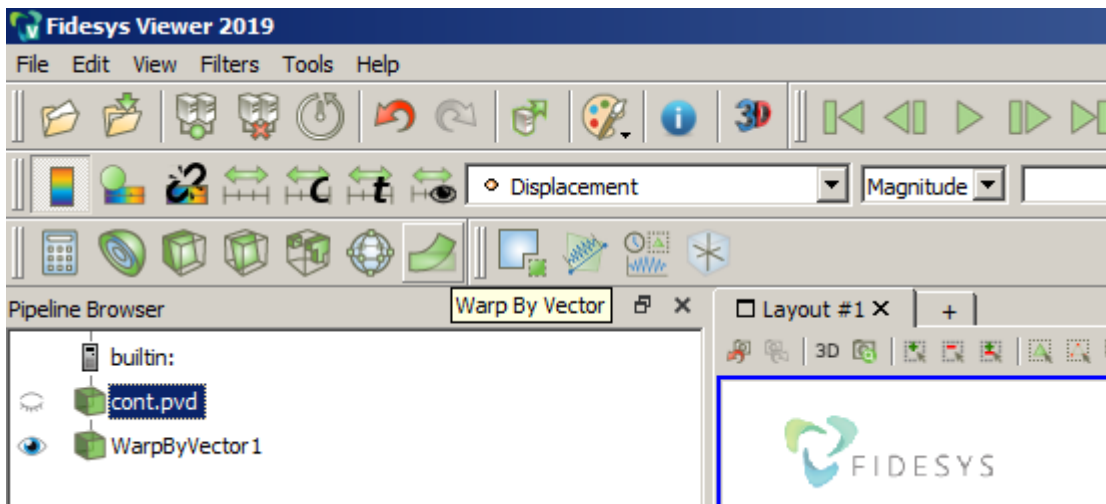

Using the console interface

Geometry generation, mesh generation, setting boundary conditions and materials can be performed using the console interface. Below is the program code that allows you to perform the steps of the above manual, you only need to **specify the full path and name of the saved file**.

```

reset
import step "D:/Fidesys/Geom_example_contact.stp" heal
volume 1 size 0.1
mesh volume 1
volume 2 size 0.3
mesh volume 2
volume 3 size 0.2
mesh volume 3
create material 1
modify material 1 name 'material1'
modify material 1 set property 'MODULUS' value 2e+11
modify material 1 set property 'POISSON' value 0.3
block 1 add volume all
block 1 material 1
block 1 element solid
    
```

```

create displacement on surface 2 27 38 dof 1 fix
create displacement on surface 5 22 23 36 dof 3 fix
create displacement on surface 30 dof all fix
create pressure on surface 17 37 magnitude 1e6
create contact autoselect friction 0.0 offset 0.055 ignore_overlap off type tied method
auto
analysis type static elasticity dim3
calculation start path "D:/Fidesys/test.pvd"
    
```



You can also run the Example_12_Contact_3D.jou file by selecting the journal editor on the toolbar. In the appeared window in the main menu, select **File** → **Open** and open the required log file.

Change of pressure in well

The problem of finding the plastic zone around the well in the dynamics, taking into account the pore pressure until instability appears in the form of plastic deformation bands, is solved.

A square plate of considerable width and unit thickness with a small circular hole of radius a in its center is subjected to all-round uniform pressures with stresses σ_1 in the direction of the X_1 axis and σ_2 in the direction of the X_2 axis. On the lateral faces of the depending on time pore pressure applied. There is pressure on a round hole, also depending on time.

It is required to calculate plastic zones around the well in dynamics.

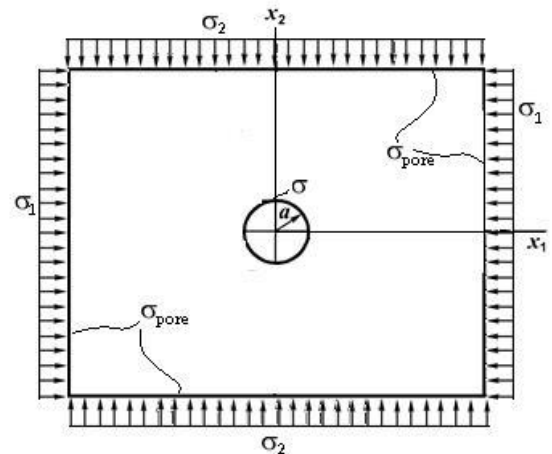

Geometry creating

1. Create a surface.

On the command panel, select the mode for constructing volume geometry (Mode - **Geometry**, Entity - **Surface**, Action - **Create**). From the list of geometric primitives, select **Rectangle**. Set block sizes:

- Width: 10;
- Height: 10;
- Location: ZPlane.

Click **Apply**.

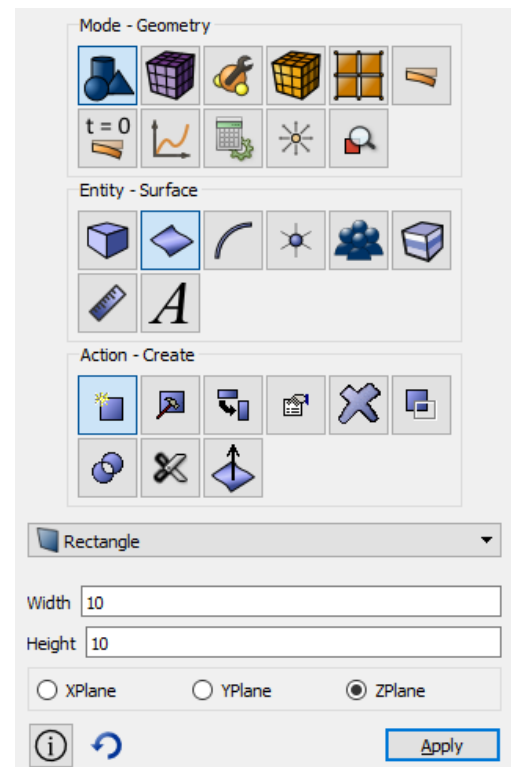

2. Moving to the origin of the coordinate system

It is required to move the surface so that one of the vertices is at the origin of the coordinate system.

On the command panel, select the mode for create volume geometry (Mode - **Geometry**, Entity - **Surface**, Action - **Transform**). From the list of geometric primitives, select **Move**. Set the movement parameters:

- Select method: distance;
- X distance: 5;
- Y Distance: 5.

Click **Apply**.

3. Selection of geometric entities

4. In the standard line we find the panel with the choice of geometric entities.

Click **Select Vertices**.

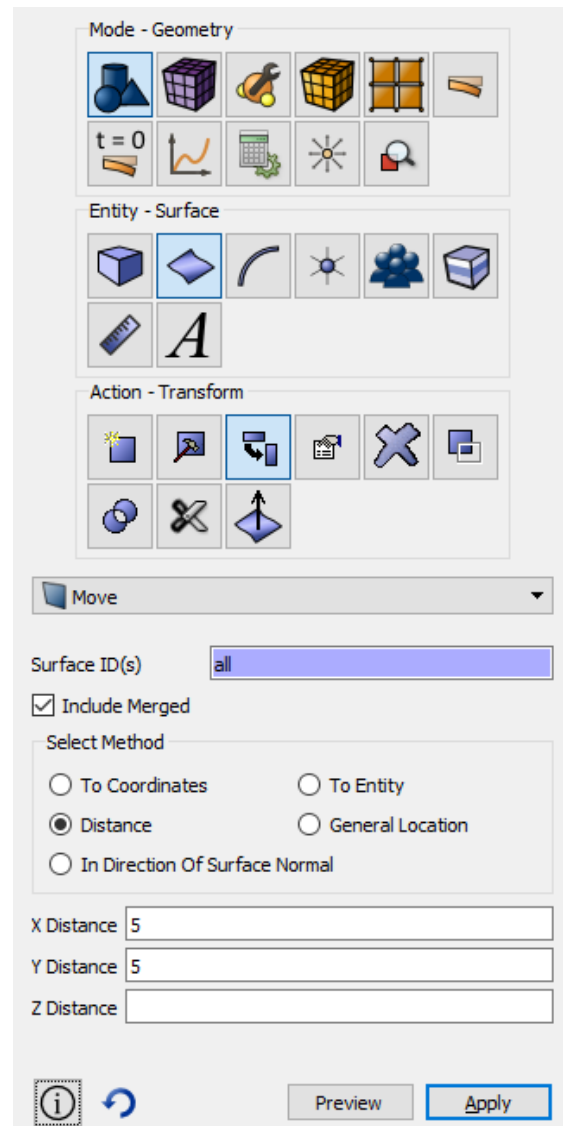

Click on the left bottom vertex of the created surface and look at the obtained coordinates on the **Properties Page** on the left. Make sure that the vertex has moved to the origin.



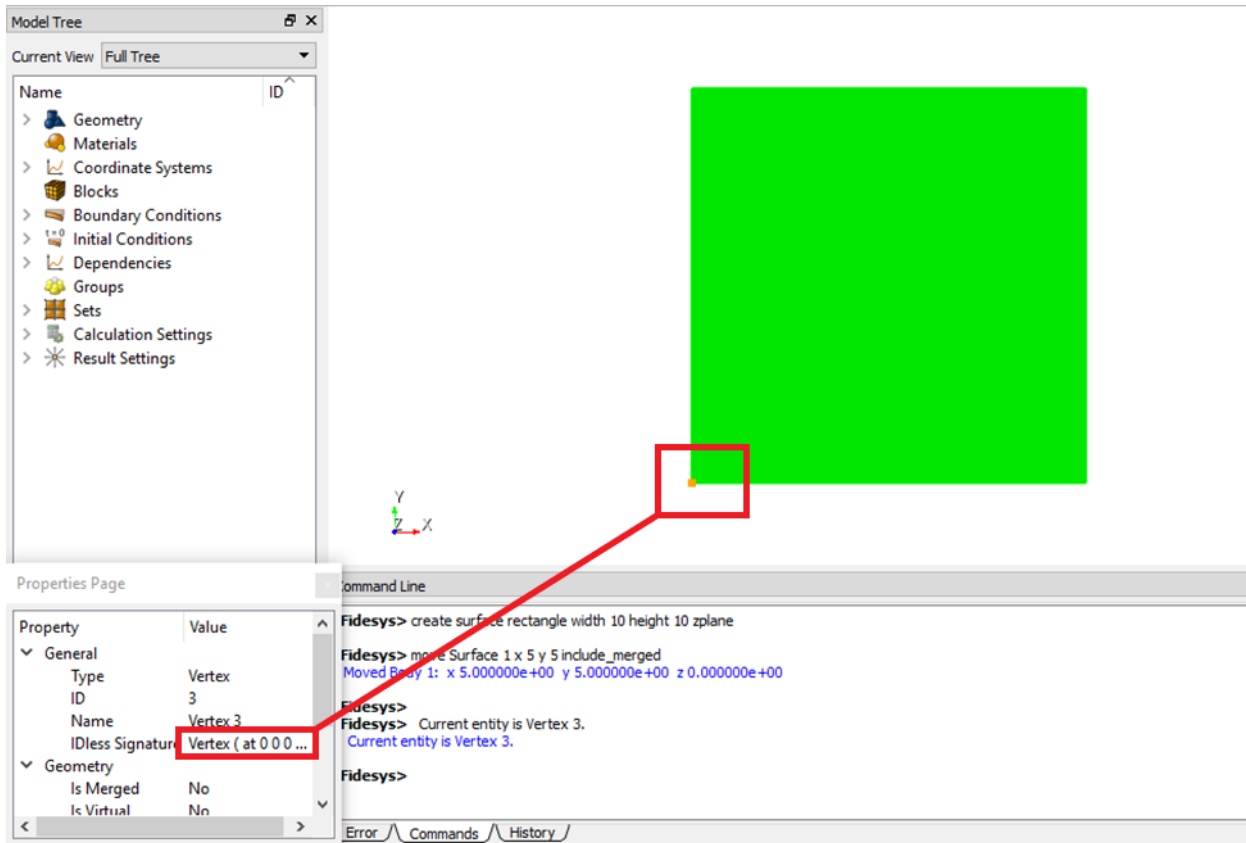

5. Creating a circular hole

It is required to make a cut in the plate using an auxiliary circle.

On the command panel, select the mode for creating volume geometry (Mode - **Geometry**, Entity - **Surface**, Action - **Create**). From the list of geometric primitives, select **Circle**. Set block sizes:

- Radius: 1;
- Location: Zplane.

Click **Apply**.

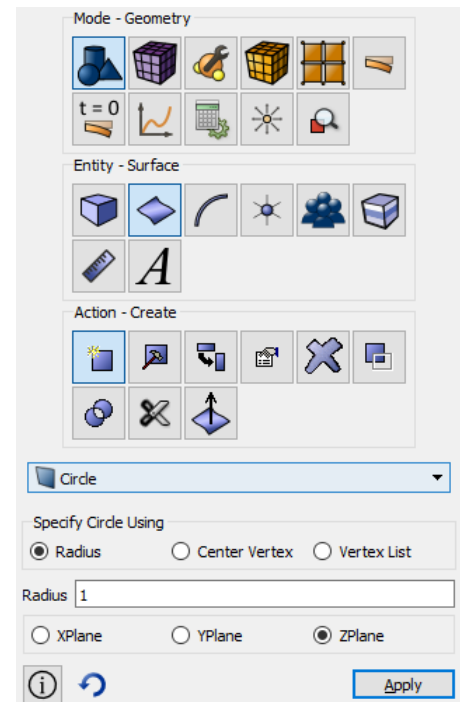
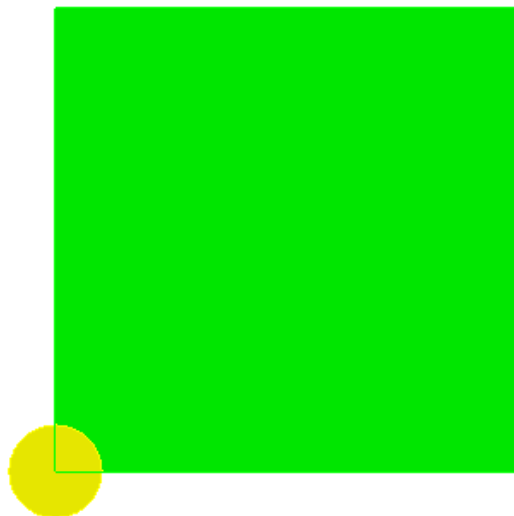

6. On the command panel, select the mode for creating volume geometry (Mode - **Geometry**, Entity - **Surface**, Action - **Boolean**). From the list of logical operations, select **Subtract**. Set the parameters of the logical operation:

- A surface ID(s): 1;
- B surface ID(s): 2;

Click **Apply**.

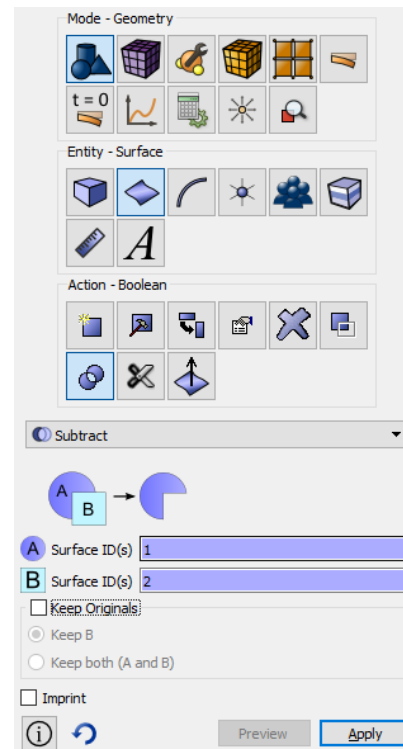

Meshing

1. Changing the mesh settings

To automatically create a quadrilateral mesh, we will change the default settings. In the standard line, select **Tools** - **Settings**. In the opened window in the left column select the **Mesh Defaults**. On the **Default Element Type** panel we select the **Hex / Quad**.

Click **Save**.

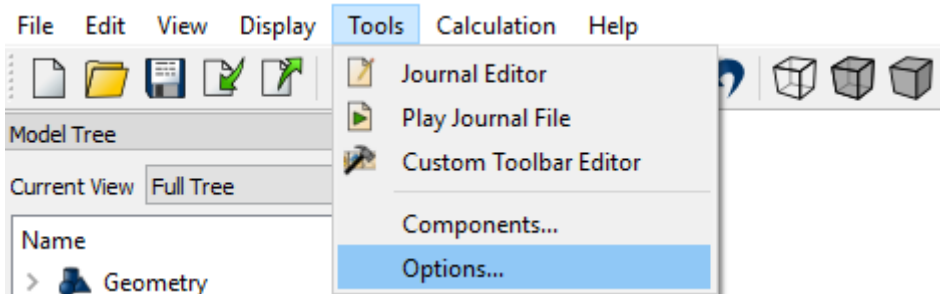



Options ? X

- Calculation options
- Command Panels
- Display
- General
- Geometry Defaults
- History
- Label Defaults
- Layout
- Mesh Defaults
- Mouse
- Paths
- Post Meshing
- > Quality Defaults

Mesh Display

Node Size

Element Shrink

Mesh Line Color

Default Element Type

Hex/Quad

Tet/Tri

Project Midnodes to Geometry

Yes No Smart

Surface Scheme Coloring (used in Meshing Power Tool)

<input type="checkbox"/> Map	<input type="checkbox"/> Circle
<input type="checkbox"/> SubMap	<input type="checkbox"/> Hole
<input type="checkbox"/> Pave	<input type="checkbox"/> Mirror
<input type="checkbox"/> TriMesh	<input type="checkbox"/> Polyhedron
<input type="checkbox"/> TriPrimitive	<input type="checkbox"/> TriDelaunay

2. In the command panel, select the mesh generation mode on curves (Mode - **Mesh**, Entity - **Curve**, Action - **Mesh**). Specify the degree of reducing mesh:

- Select curves: 7;
- Select the mesh generation method: Bias;
- Select the mesh generation method: Intervals & Bias;
- Interval count: 70;
- Bias Factor: 1.04;
- Start vertex ID: 7 (left vertex on the given curve).

Click **Apply Size**.

Click **Mesh**.

3.

The screenshot displays the CAE Fidesys command panel for mesh generation on curves. It is organized into three main sections: Mode, Entity, and Action.

- Mode - Mesh:** Contains icons for various meshing modes, with the 'Mesh' icon (a cube) selected.
- Entity - Curve:** Contains icons for different curve entities, with the 'Curve' icon (a line) selected.
- Action - Mesh:** Contains icons for meshing actions, with the 'Mesh' icon (a cube) selected.

Below these sections, the 'Select Curves' field is set to '7'. The 'Get Settings For Curve 12' button is visible. The 'Bias' dropdown is selected, and the 'Intervals & Bias' dropdown is also selected. The 'Change Interval Count' checkbox is checked, and the 'Interval Count' is set to 70. The 'Dual Bias' checkbox is unchecked. The 'Bias Factor' is set to 1.04, with a corresponding slider. The 'Start Vertex ID' is set to 7. The 'Modify Curve Sense' checkbox is checked. The 'Preview' checkbox is checked, and the 'Apply Size' button is visible. The 'Apply Size Before Meshing' checkbox is checked, and the 'Mesh' button is visible.

4. On the command panel, select the mesh generation mode on curves (Mode - **Mesh**, Entity - **Curve**, Action - **Mesh**). Specify the degree of reducing mesh:

- Select curves: 8;
- Select the mesh generation method: Bias;
- Select the mesh generation method: Intervals & Bias;
- Bias Factor: 70;
- Bias Factor: 1.04;
- Start vertex ID: 6 (lower vertex on this curve).

Click **Apply Size**.

Click **Mesh**.

The screenshot displays the software's command panel for mesh generation on curves. It is organized into three main sections: Mode, Entity, and Action.

- Mode - Mesh:** Contains icons for various meshing modes, with 'Mesh' selected.
- Entity - Curve:** Contains icons for different entity types, with 'Curve' selected.
- Action - Mesh:** Contains icons for different meshing actions, with 'Mesh' selected.

Below these sections, the following settings are visible:

- Select Curves:** A text input field containing the number '8'.
- Get Settings For Curve 12:** A button labeled 'Get Settings'.
- Bias:** A dropdown menu currently set to 'Bias'.
- Intervals & Bias:** A dropdown menu currently set to 'Intervals & Bias'.
- Change Interval Count:** A checked checkbox.
- Interval Count:** A text input field containing '70'.
- Dual Bias:** An unchecked checkbox.
- Bias Factor:** A text input field containing '1.04' and a slider below it.
- Start Vertex ID:** A text input field containing '6'.
- Modify Curve Sense:** A checkbox that is currently unchecked.
- Preview:** A checked checkbox.
- Apply Size Before Meshing:** A checked checkbox.
- Buttons:** 'Apply Size' and 'Mesh' buttons are located at the bottom right.

5. In the command panel, select the mesh generation module on curves (Mode - **Mesh**, Entity - **Curve**, Action - **Mesh**). Specify the degree of reducing mesh:

- Curve selection: 6 1 4 (separated by spaces);
- Select the mesh generation method: Equal;
- Set the flag: Interval;
- Indicate the number of intervals: 34.

Click **Apply Size**.

Click **Mesh**.

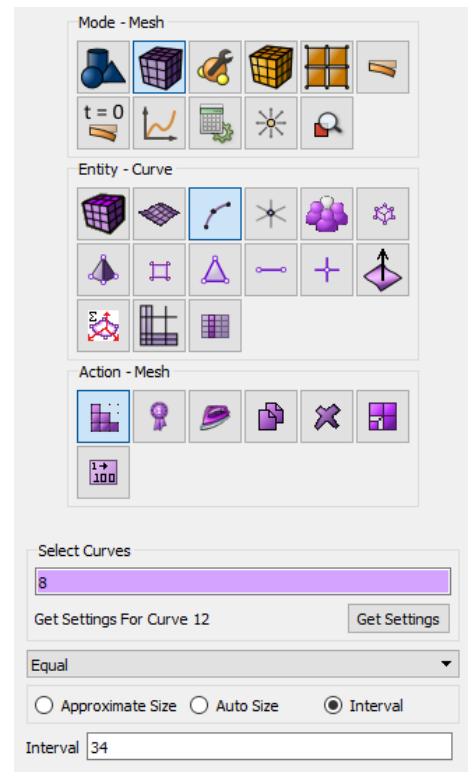

6. On the command panel, select the surface mesh generation mode (Mode - **Mesh**, Entity - **Surface**, Action - **Intervals**).

- Automatic size;
- Surface selection: 3.

Click **Mesh**.

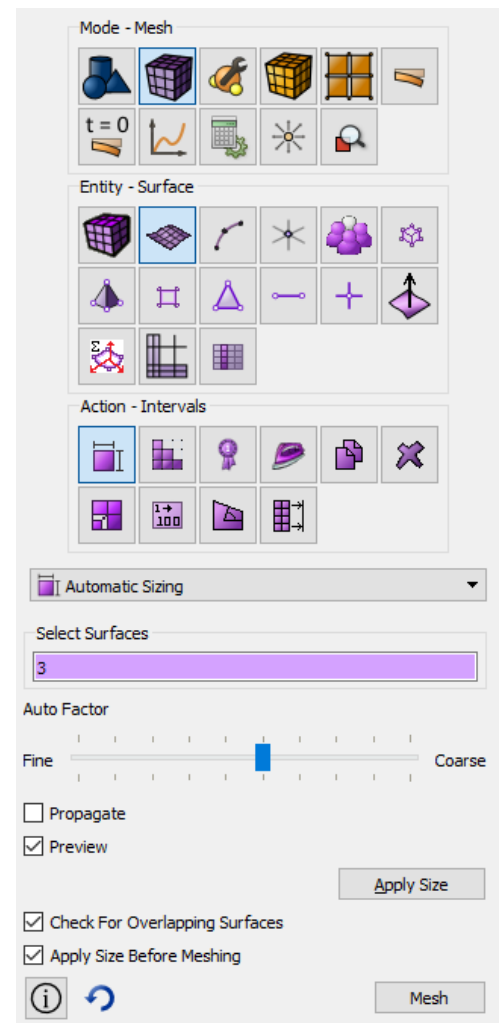

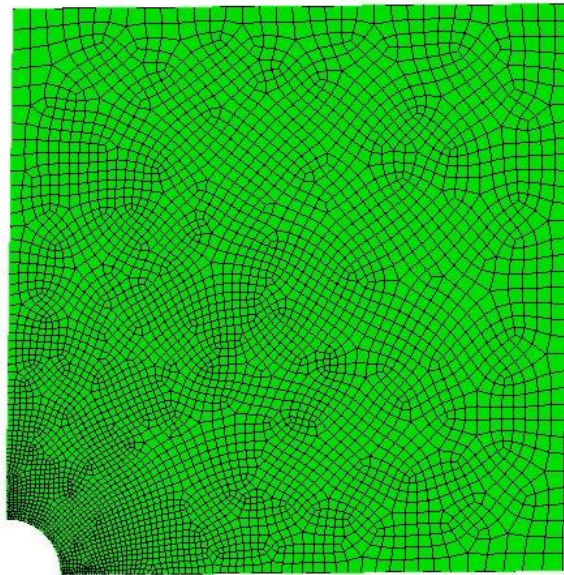

Specifying the material and type of element

1. Create a material.

On the command panel, select the mode for setting material properties (Mode — **Material**, Entity -

Materials management). In the Material Management widget that opens, in the middle column specify the name of the material material. In the properties column, open the **Elasticity** list and drag the name **Hooke Material** into the Material Properties column.

Set the following parameters:

- Young's modulus: 1e9;
- Poisson's ratio: 0.25.

In the left column, go to the General section and select **Density**. Drag the mouse into the right column and specify the value 2650.

- Density: 2650.

In the left column, go to the **Plasticity** section and select the **Drucker-Prager Second Strength Criterion**.

- Cohesion: 2e6;
- Internal friction angle: 20;
- Dilatancy angle: 0.001.

In the left column go to the section **Geomechanics - Biot Isotropic model**.

- Porosity: 0.25;
- Permeability: 1e-12;
- Fluid's viscosity: 0.005;
- Biot alpha: 0.8;
- Fluid's bulk modulus: 1e9.

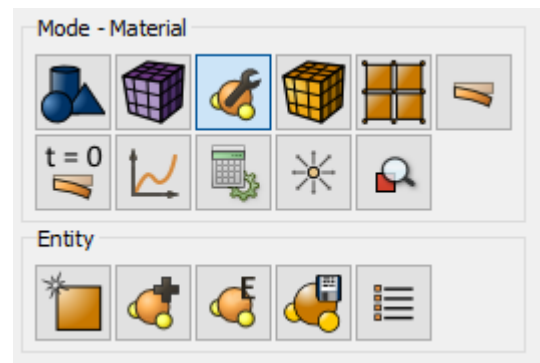

Click **Apply**.

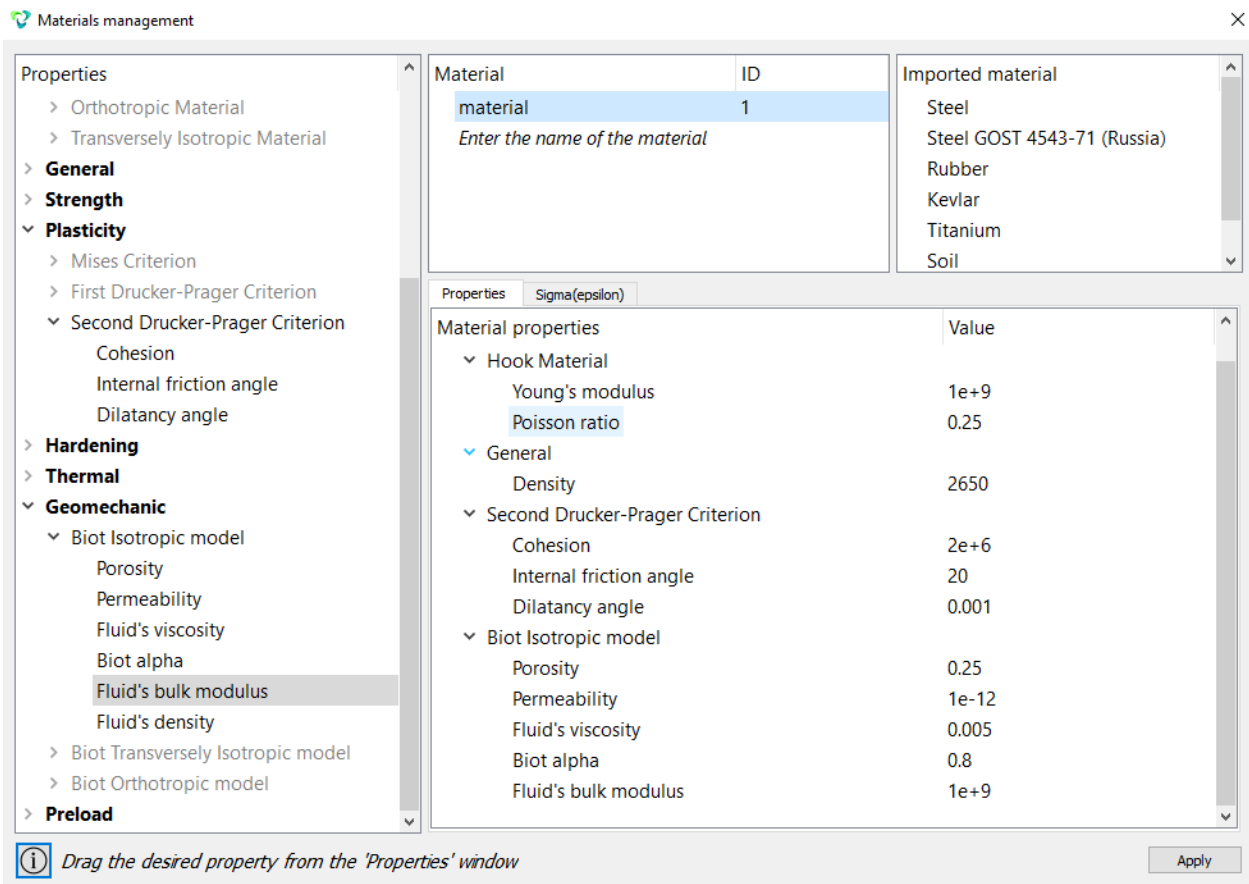

2. Create a block of the one type of material.

On the command panel, select the mode for setting material properties (Mode - **Blocks**, Entity - **Block**, Action - **Add**). Set the following parameters:

- Block ID: 1;
- Entity List: Surface;
- Entity ID(s): 3.

Click **Apply**.

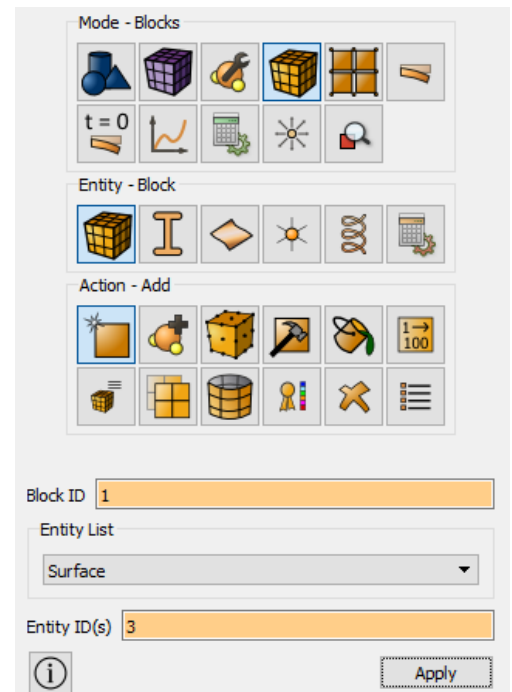

3. Assign the material to the block.

On the command panel, select the mode for setting material properties (Mode - **Blocks**, Entity - **Block**, Action - **Set Material**). Set the following parameters:

- Block ID (s): 1;
- Available material: material1.

Click **Apply**.

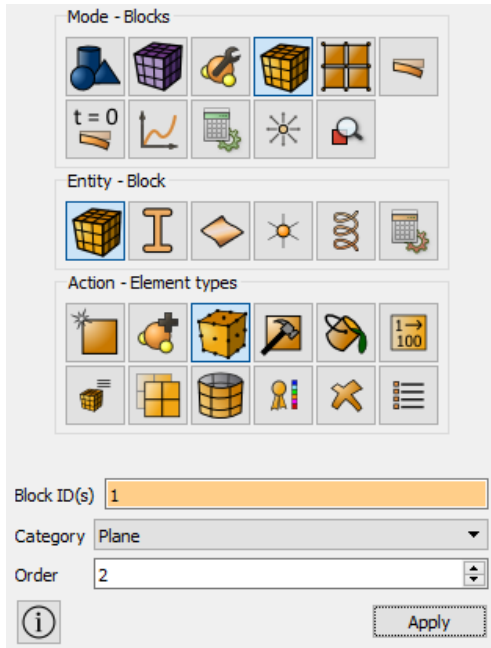
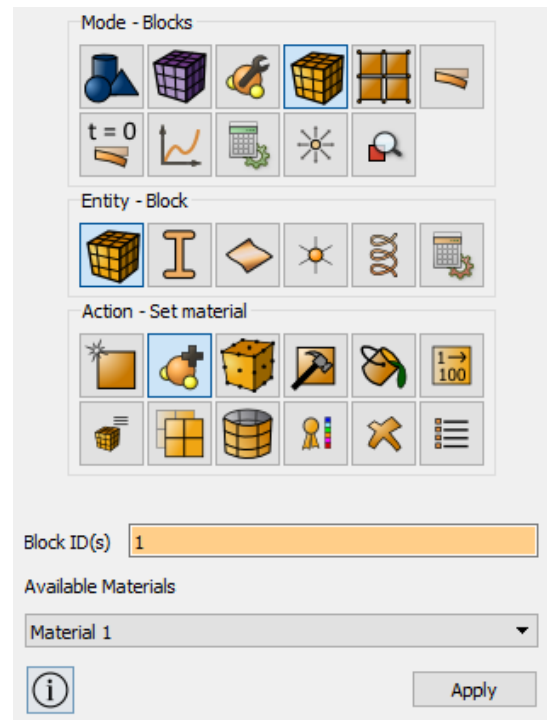

4. Assign an element type.

On the command panel, select the mode for setting material properties (Mode - **Blocks**, Entity - **Block**, Action - **Element types**). Set the following parameters:

- Block ID (s): 1;
- Category: Plane;
- Order: 2.

Click **Apply**.

Setting boundary conditions

1. Apply pressure to the right side curve.

On the command panel, select Mode - **Boundary conditions**, Entity - **Pressure**, Action - **Create**. Set the following parameters:

- System Assignet ID;
- Pressure Entity List: Curve;
- Entity ID(s): 4;
- Magnitude Value: 28e6 (the exponential type of number is supported using the Latin letter "e").

Click **Apply**.

2. Apply pressure to the right side curve.

On the command panel, select Mode - **Boundary conditions**, Entity - **Pressure**, Action - **Create**. Set the following parameters:

- System Assignet ID;
- Pressure Entity List: Curve;
- Entity ID(s): 1;
- Magnitude Value: 32e6 (the exponential type of number is supported using the Latin letter "e").

Click **Apply**.

3. Set the time-dependent load on the model's notch.

On the command panel, select Mode - **Boundary conditions**, Entity - **Pressure**, Action - **Create**. Set the following parameters:

- System Assignet ID;
- Pressure Entity List: Curve;
- Entity ID(s): 6;
- Magnitude Value: 0;

Click **Apply**.

On the command panel, select Mode - **Boundary conditions**, Entity - **Set time and/or coordinate BC dependency**.

In the appeared **BC Dependencies** window set the following parameters:

Mode - Boundary Conditions

Entity - Pressure

Pressure Entity List

Entity ID(s) 4

Magnitude Value 28E6

Interpret Value As

Use Pure Pressures

Apply Pressure On

Top

Apply

Mode - BC Dependency

t = 0



- BC name: Pressure 3;
- Select the Formula flag: Custom;
- In the field below enter $(25e6) - 0.6e6 * t / 3600$.

BC Dependency ×

BC Type	BC Name	ID
	Pressure	1
	Pressure	2
	Pressure	3

Formula Table Plot

Custom ▾

$(25e6) - 0.6e6 * t / 3600$

Clear	+	-	*	/	^
sin	cos	tan	sqrt	if(A,B,C)	()
asin	acos	atan	exp	log	log10
sinh	cosh	tanh	abs	ceil	floor

Available variables: t (time), x (x-coordinate), y (y-coordinate), z (z-coordinate), T (temperature), w (frequency)

Apply

Click **Apply**.



4. Specify symmetric fixing.

On the command panel, select **Mode - Boundary Conditions, Entity - Displacement, Action - Create**. Set the following parameters:

- System Assignet ID;
- Entity List: Curve;
- Entity ID(s): 7;
- Degrees of freedom: Y-Translation Disp;

Click **Apply**.

Similarly, set the second fixture for the line 8.

Mode - Boundary Conditions

Entity - Displacement

Action - Create

ID/Name

New ID

Name

System Assigned ID

Entity List

Nodeset Volume Surface Curve

Hex Tet Face Vertex

Tri Edge Node

Entity ID(s) 7

Degrees Of Freedom

All

X-Translation Disp X-Rotation Disp

Y-Translation Disp Y-Rotation Disp

Z-Translation Disp Z-Rotation Disp

DOF Value 0

Specify Combination

Overwrite Average

Smallest Largest

Mode - Boundary Conditions

Entity - Displacement

Action - Create

ID/Name

New ID

Name

System Assigned ID

Entity List

Nodeset Volume Surface Curve

Hex Tet Face Vertex

Tri Edge Node

Entity ID(s) 8

Degrees Of Freedom

All

X-Translation Disp X-Rotation Disp

Y-Translation Disp Y-Rotation Disp

Z-Translation Disp Z-Rotation Disp

DOF Value 0

Specify Combination

Overwrite Average

Smallest Largest

On the command panel, select **Mode - Boundary Conditions, Entity - Displacement, Action - Create**. Set the following parameters:

- System Assignet ID;
- Entity List: Curve;
- Entity ID(s): 8;
- Degrees of freedom: X-Translation Disp;

Click **Apply**.

5. Set the pore pressure.

On the command panel, select Mode - **Boundary conditions**, Entity - **Pore pressure**, Action - **Create**. Set the following parameters:

- System Assignet ID;
- Entity List: Curve;
- Entity ID(s): 1 4 (in the ID field, numbers are separated by spaces);
- DOF Value: $(25e6) - 0.6e6 * t / 3600$.

Click **Apply**.

The screenshot displays the 'Boundary Conditions' panel in the software. It is organized into three main sections: 'Mode - Boundary Conditions', 'Entity - Pore Pressure', and 'Action - Create'. The 'Entity - Pore Pressure' section is active, showing various icons for defining the boundary condition. Below these sections are input fields for 'ID/Name', 'Entity List', 'Entity ID(s)', and 'Value'. The 'ID/Name' section has 'System Assigned ID' selected. The 'Entity List' dropdown is set to 'Curve'. The 'Entity ID(s)' field contains '1 4'. The 'Value' field contains the mathematical expression $(25e6) - 0.6e6 * t / 3600$. An 'Apply' button is located at the bottom right of the panel.

Mode - Boundary Conditions

Entity - Pore Pressure

Action - Create

ID/Name

New ID

Name

System Assigned ID

Entity List

Curve

Entity ID(s) 1 4

Value $(25e6) - 0.6e6 * t / 3600$

Apply

Run the calculation

1. Set the solver parameters.

On the command panel, select the calculation settings module (Mode - **Calculation Settings**, Calculation Settings - **Transient analysis**, Transient - **General**). Set the following parameters:

- Dimension: 2D;
- Plain state: Plane strain;
- Max time: 15000;
- Steps count: 1000;

Check the **Preload model** box;

In the Models section, select the check boxes for **Elasticity**, **Plasticity**, **Pore fluid transfer**.

Select the check box for **Set implicit scheme options**.

In the field **Newmark algorithm gamma**, enter **0.1**.

Click **Apply**.

Click **Start calculation**.

2. In the window that appears, select the directory in which the result will be saved, and enter the file name.
3. In case of a successful calculation, the console will display the message: "*Calculation finished successfully at <date> <time>*".

Mode - Calculation Settings

Calculation settings - Transient analysis

Transient - General

Dimensions: 2D

Plain state

Plane strain

Plane stress

Use MPI

Method: Full solution

Scheme: Implicit

Options

Max time: 15000

Steps count: 1000

Time step: 15

Preload model

Model

Elasticity

Plasticity

Nonlinear geometry

Heat transfer

Pore Fluid Transfer

Set load steps count

Set nonlinear solver options

Set implicit scheme options

Implicit scheme options

Newmark algorithm gamma: 0.1

Apply

Start Calculation

Results analysis

1. Open the file with the results. This can be done in three ways.
 - Press Ctrl + E.
 - From the main menu, select **Calculation** → **Results**. Click **Open Last Result**.

View the calculation results in the *Fidesys Viewer* window.



To automatically apply changes to all filters, click the corresponding button **Apply changes to parameters automatically** on the command bar.

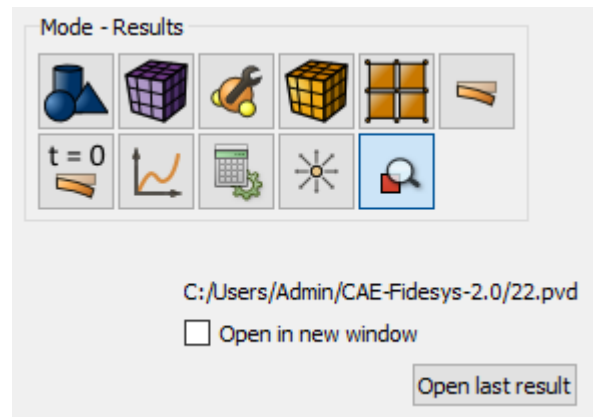

Find in the standard line, the **Edit color map** icon. 

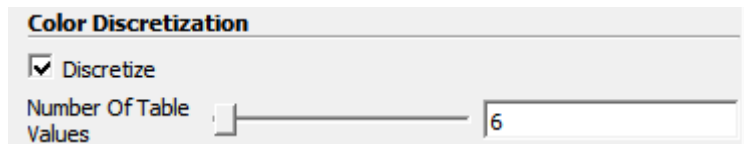

On the Color discretization panel, in the **Number of table values** field, set the value to 6.

In the top pane, select the calculation result data to display. From the first drop-down list, select **Stress**, and from the second - **Mises**.

The results of the Mises Stress are presented below (the default results are for the last step of the calculation at the time point of 150000 s)

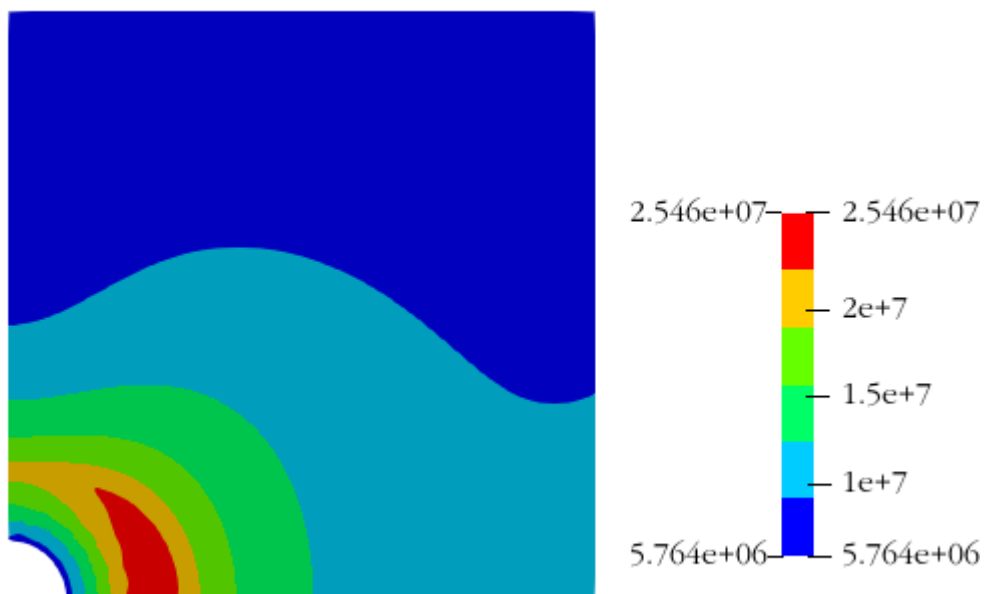

Results - Mises Stress

Similarly, we will display the remaining results.

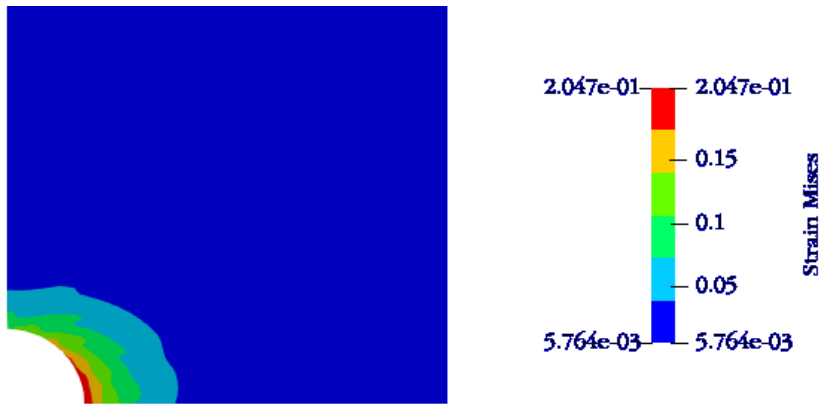

Results - Plastic Strain (Mises)

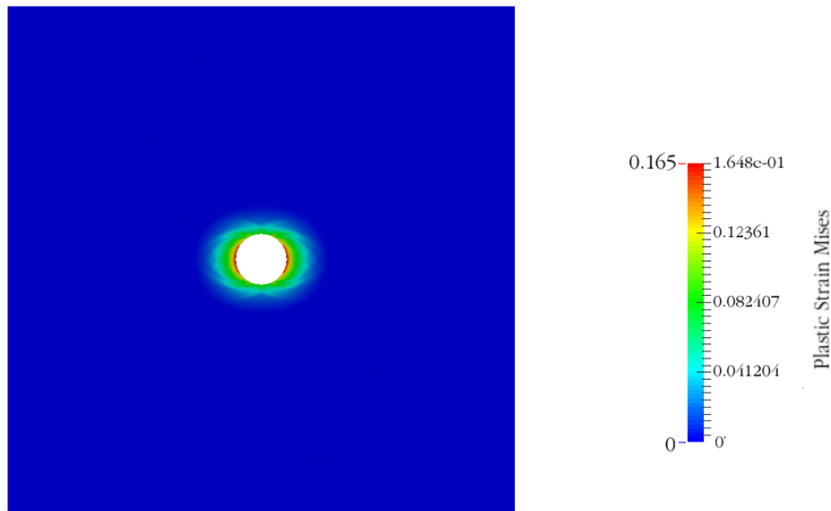

Results - Plastic strain on a full plate

Complete the model and consider plastic deformations on the full plate. Use the **Filter - Alphabetical - Flip**. On the property page, in the **Plane** field, indicate **X**. Then we apply the filter **Flip** again to this filter, but in the **Plane** field, we specify **Y**.

On another color scheme, the kind distribution of plastic strains may be more pronounced.

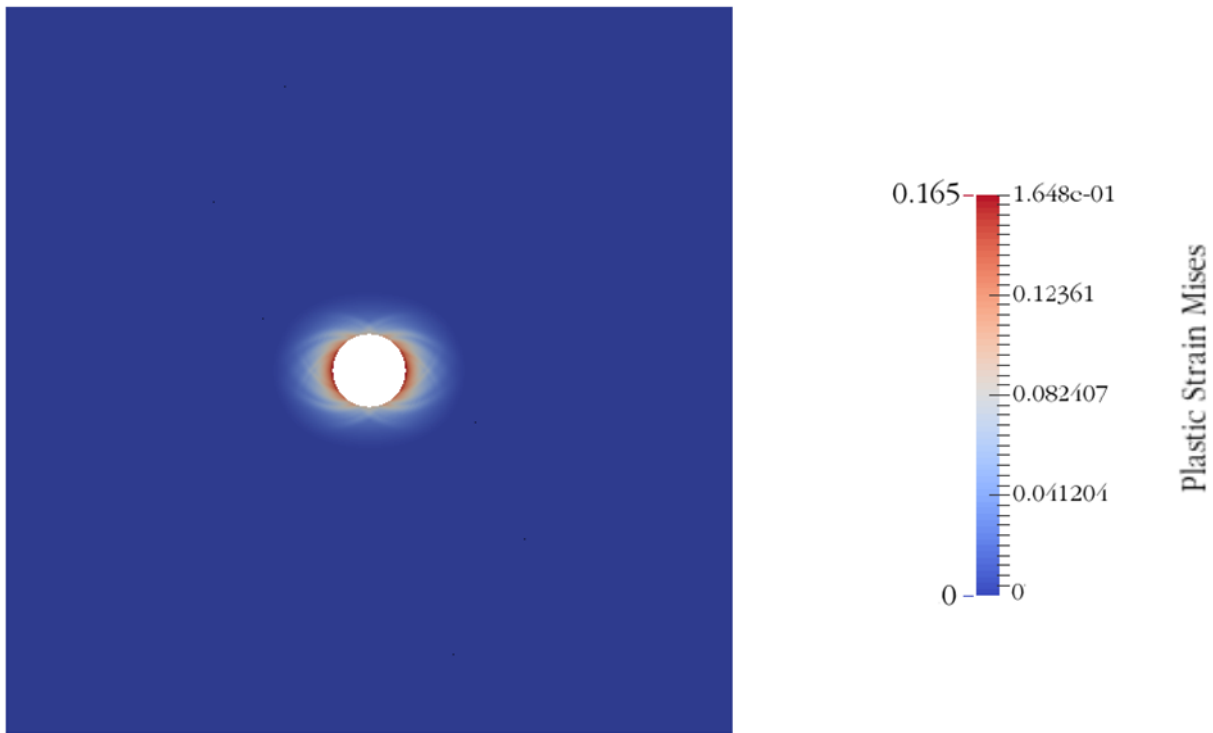

Results - Plastic strain on the full plate (another color scheme)

Estimate the safety margin

In the standard line, select **Filters** → **Alphabetical Index** → **Safety Factor**.

Select the fields to display on the model - **Safety Factor** and **Coulomb-More Theory**.

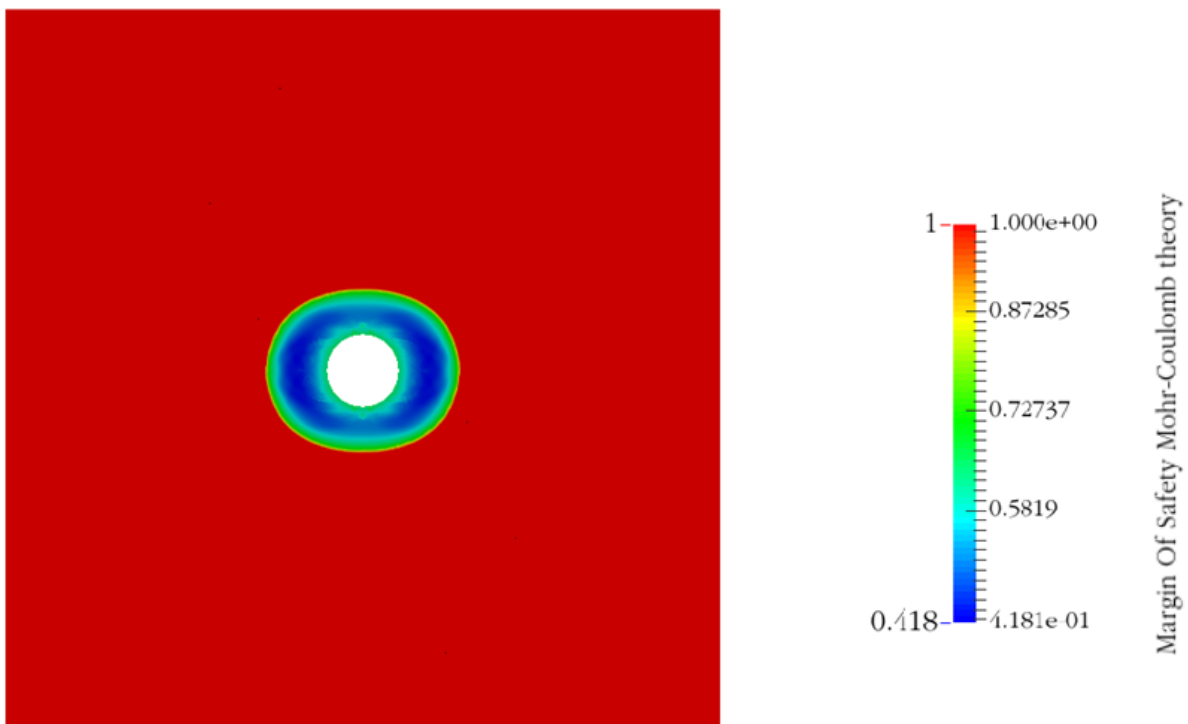

The result of the calculation of the safety factor according to the theory of Coulomb-More

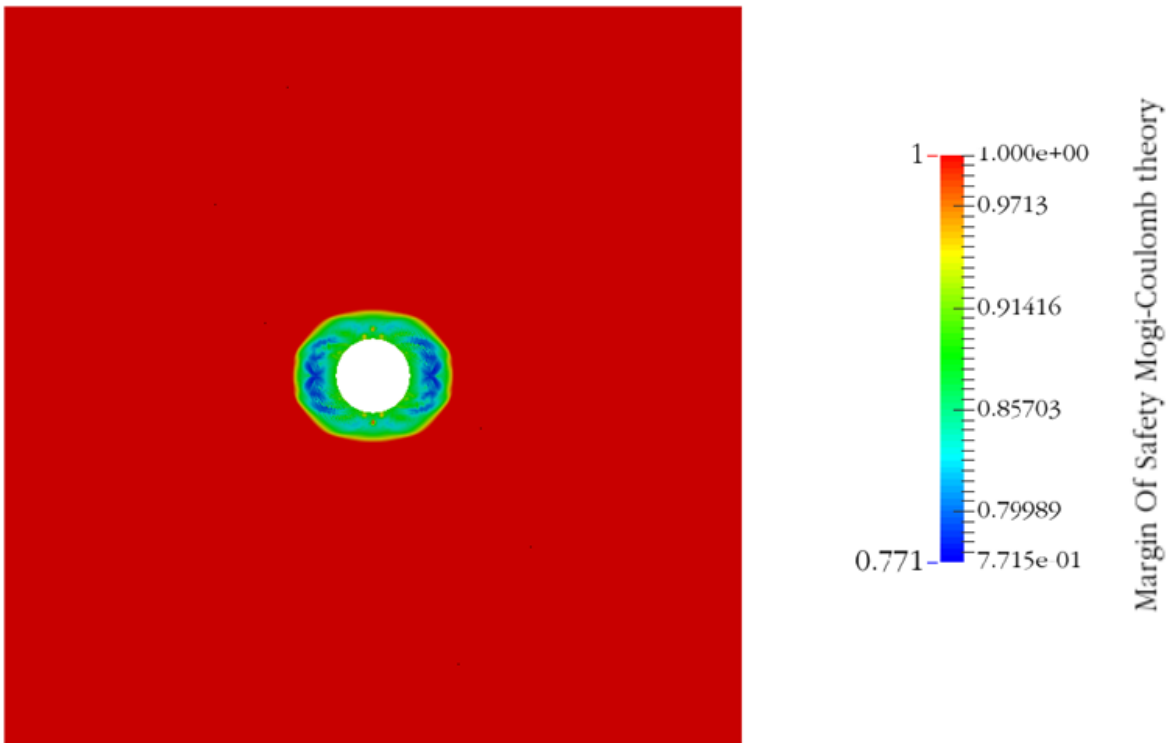

The result of the calculation of the safety factor according to the theory of Mogi- Coulomb

Thus, the calculation of the plastic zone around the well was made in dynamics, taking into account the pore pressure until instability appears in the form of plastic deformation bands.

Using the console interface

Geometry creation, mesh generation, setting boundary conditions and materials can be performed using the console interface. Below is the program code that allows performing the steps of the above manual, you need only to **specify the full path and name of the saved file**.

```

reset
set node constraint on
create surface rectangle width 10 height 10 zplane
move surface 1 x 5 y 5
create surface circle radius 1 zplane
subtract body 2 from body 1
curve 7 interval 70
curve 7 scheme bias factor 1.04 start vertex 7
mesh curve 7
curve 8 interval 70
curve 8 scheme bias factor 1.04 start vertex 6
mesh curve 8
curve 6 interval 34
curve 1 4 interval 34
mesh curve 1 4 6
mesh surface all
create material 1
modify material 1 name 'material'
modify material 1 set property 'MODULUS' value 1e+09
modify material 1 set property 'POISSON' value 0.25
modify material 1 set property 'DENSITY' value 2650
    
```



```
modify material 1 set property 'COHESION' value 2e+06
modify material 1 set property 'INT_FRICTION_ANGLE' value 20
modify material 1 set property 'DILATANCY_ANGLE' value 0.0001
modify material 1 set property 'BIOT_ALPHA' value 0.8
modify material 1 set property 'POROSITY' value 0.25
modify material 1 set property 'PERMEABILITY' value 1e-12
modify material 1 set property 'FLUID_VISCOCITY' value 0.005
modify material 1 set property 'FLUID_BULK_MODULUS' value 1e9
block 1 add surface all
block 1 element type quad8
block 1 material 'material'
create pressure on curve 4 magnitude 28e6
create pressure on curve 1 magnitude 32e6
create pressure on curve 6 magnitude 0
bcdep pressure 3 value '(25e6)-0.6e6*t/3600'
create displacement on curve 7 dof 2 fix 0
create displacement on curve 8 dof 1 fix 0
create porepressure on curve 1 4 value 25e6
create formula 1 '(25e6)-0.6e6*t/3600'
create porepressure on curve 6 formula 1
analysis type dynamic elasticity plasticity porefluidtrans dim2 planestrain preload on
dynamic method full_solution scheme implicit maxtime 150000 timestep 1000 newmark_gamma
0.1
nonlinearopts maxiters 2000 minloadsteps 1 maxloadsteps 10000000 tolerance 1e-4 targetiter
5
calculation start path 'D:\Kirsch_pore.pvd'
```



You can also run the Example_13_Plasticity_2D.jou file by selecting the journal editor on the toolbar. In the appeared window in the main menu, select **File** → **Open** and open the required log file.

The loading history of the elastic-plastic plate

Hinton E. *Fundamental Tests for Two and Three-dimensional, Small Strain, Elastoplastic Finite Element Analysis* / Ernest Hinton, M.H. Ezatt. - NAFEMS, 1987.

The problem of tension-compression of a square plate is solved. Material parameters: $E = 250e3 \text{ N/mm}^2$, $\nu = 0.25$, yield strength $c = 5 \text{ N/mm}^2$. The model is meshed into one finite element. The left and bottom sides are fixed perpendicularly. The boundary conditions are presented in the figure below:

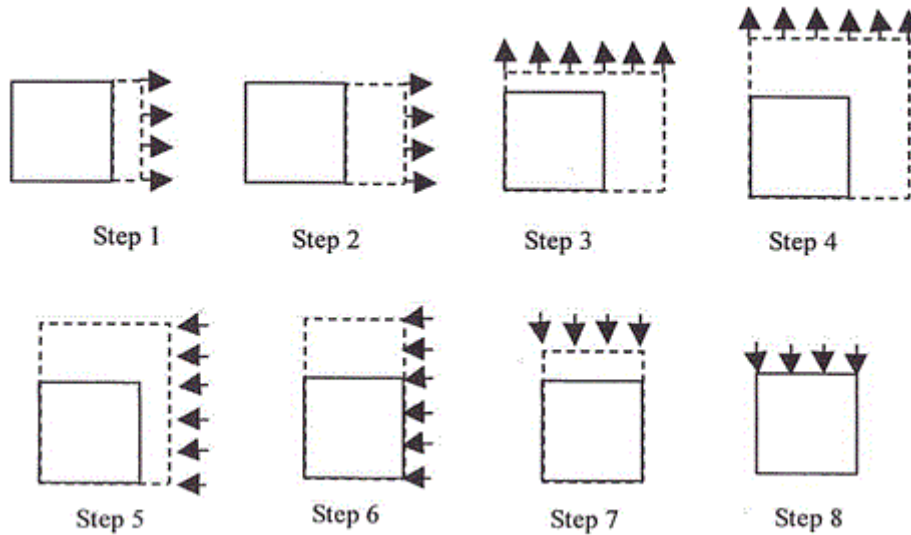

Geometry creating

1. Create a square plate.

On the command panel, select the mode for creating volume geometry (Mode - **Geometry**, Entity - **Surface**, Action - **Create**). From the list of geometric primitives, select **Rectangle**. Set block sizes:

- Width: 1;
- Location: Zplane.

Click **Apply**.

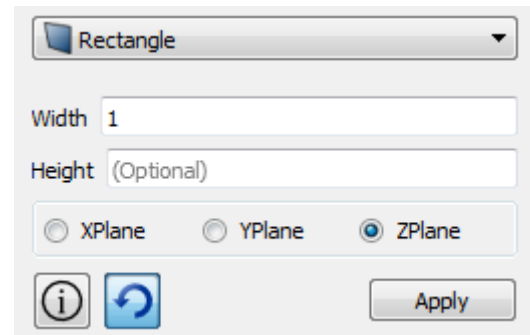

2. Move the surface to the origin of CS.

On the command panel, select the mode for creating volume geometry (Mode - **Geometry**, Entity - **Surface**, Action - **Transform**). From the list of possible transformations, select **Move**. Set the parameters:

- Surface ID(s): 1;
- Including Merged: uncheck;
- Select method: Distance;
- X Distance: 0.5;
- Y Distance: 0.5.

Click **Apply**.

Thus, the lower left corner of the plate has moved to the origin of CS.

Move

Surface ID(s) 1

Include Merged

Select Method

To Coordinates To Entity

Distance General Location

In Direction Of Surface Normal

X Distance 0.5

Y Distance 0.5

Z Distance

Meshing

1. On the command panel, select the meshing mode on the curves (Mode - **Mesh**, Entity - **Curve**, Action - **Mesh**). Specify the degree of refining mesh:

- Select Curves: all;
- Select the meshing method: Equal;
- Select the meshing options: Interval;
- Interval: 1.

Click **Apply Size**.

Click **Mesh**.

Select Curves

all

Settings For Curve

Equal

Approximate Size Auto Size Interval

Interval 1

Preview

Apply Size Before Meshing

2. On the command panel, select the surface meshing mode (Mode - **Mesh**, Entity - **Surface**, Action - **Mesh**):

- Select the mesh scheme: Automatically Calculate;
- Select Surfaces: all.

Click **Apply Scheme**.

Click **Mesh**.

Automatically Calculate

Select Surfaces

all

Check For Overlapping Surfaces

Apply Scheme Before Meshing

Scheme: Default

Specifying the material and element type

1. Create material

On the command panel, select the mode for setting material properties (Mode - **Material**, Entity - **Materials Management**). Specify the name of the material Material 1. Drag the Hooke Material inscription from the left column into the Material Properties column. Set the following parameters:

- Young's modulus: 250e3;
- Poisson ratio: 0.25;

In the window on the left, go to the section Plasticity – Mises Criterion. Drag the Yield strength feature into the Material Properties window. Enter value:

- Yield strength: 5.

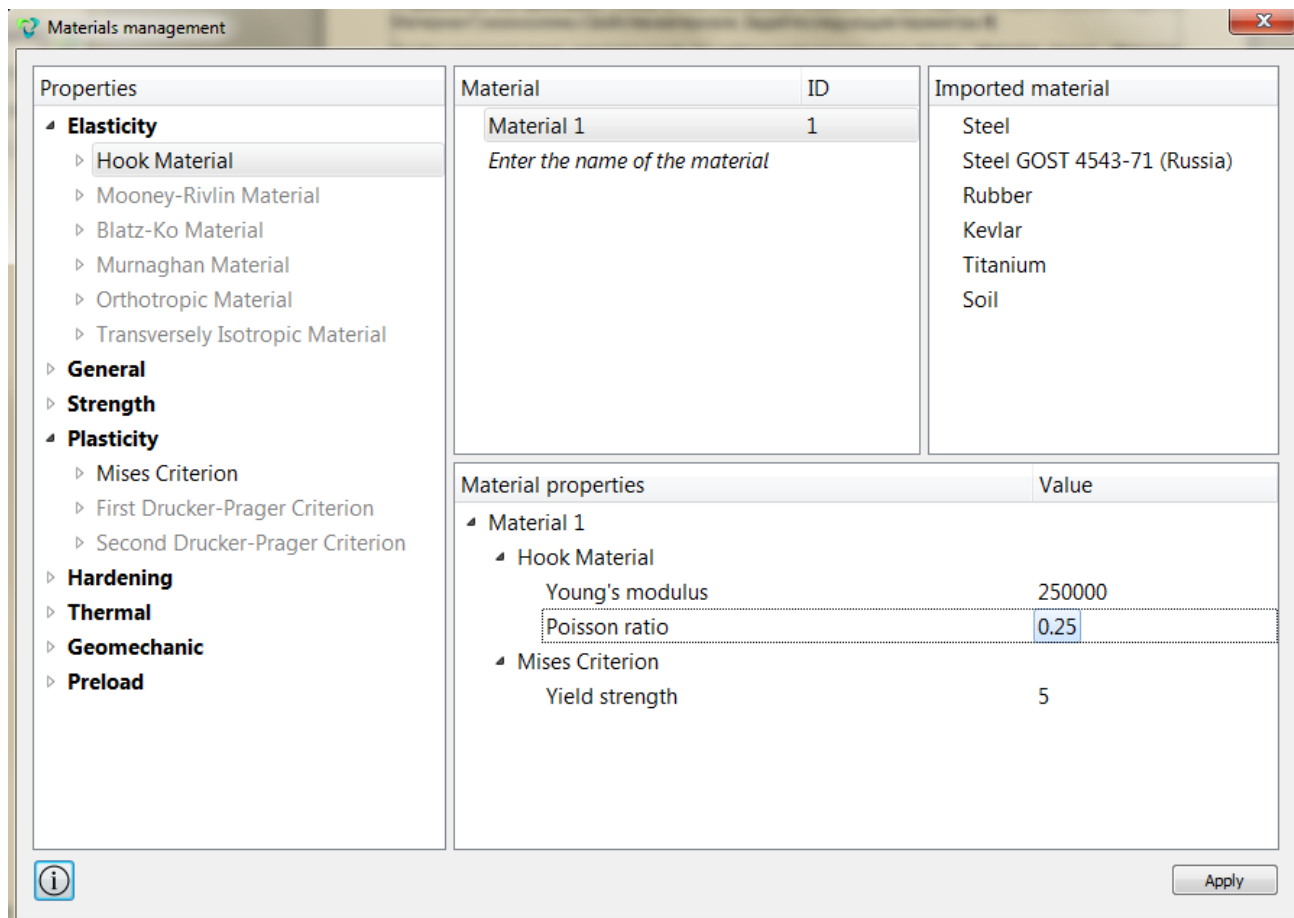

Click **Apply**.

2. Create a block of the one type of material.

On the command panel, select the mode for setting material properties (Mode - **Blocks**, Entity - **Block**, Action - **Add**). Set the following parameters:

- Block ID: 1;
- Entity list: Surface;
- Entity ID(s): 1 (or by command all).

Click **Apply**.

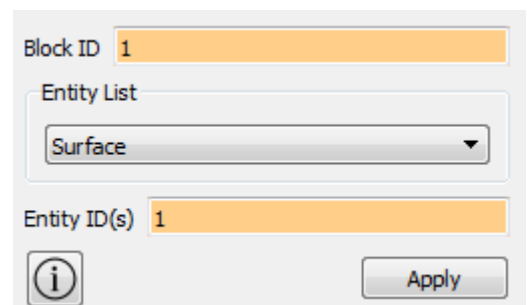

3. Assign Material to Block

On the command panel, select the mode for setting material properties (Mode - **Blocks**, Entity - **Block**, Action - **Set Material**). Set the following parameters:

- Block ID(s): 1;
- Select a previously created material from the list: Material 1.

Click **Apply**.

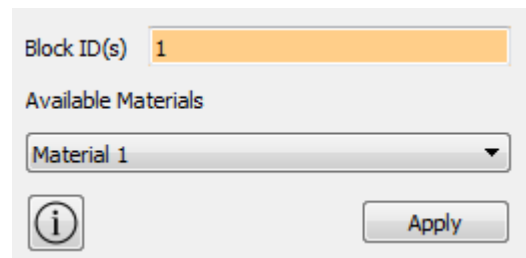

4. Assign an element type.

On the command panel, select the mode for setting material properties (Mode - **Blocks**, Entity - **Block**, Action - **Element types**). Set the following parameters:

- Block ID(s): 1;
- Category: Plane;
- Order: 2.

Click **Apply**.

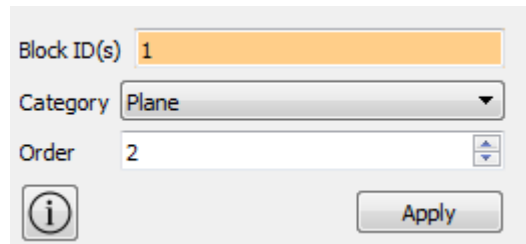

Setting boundary conditions

1. Fix curve 3 in the Y direction.

On the command panel, select Mode - **Boundary Conditions**, Entity - **Displacement**, Action - **Create**. Set the following parameters:

- System assigned ID;
- Entity list: Curve;
- Entity ID(s): 3;
- Degrees of freedom: Y-Translation Disp;
- DOF Value: 0.

Click **Apply**.

2. Fix curve 2 in the X direction.

On the command panel, select Mode - **Boundary Conditions**, Entity - **Displacement**, Action - **Create**. Set the following parameters:

- System assigned ID;
- Entity list: Curve;
- Entity ID(s): 2;
- Degrees of freedom: X-Translation Disp;
- DOF Value: 0.

Click **Apply**.

3. Fix curve 4 in the X direction.

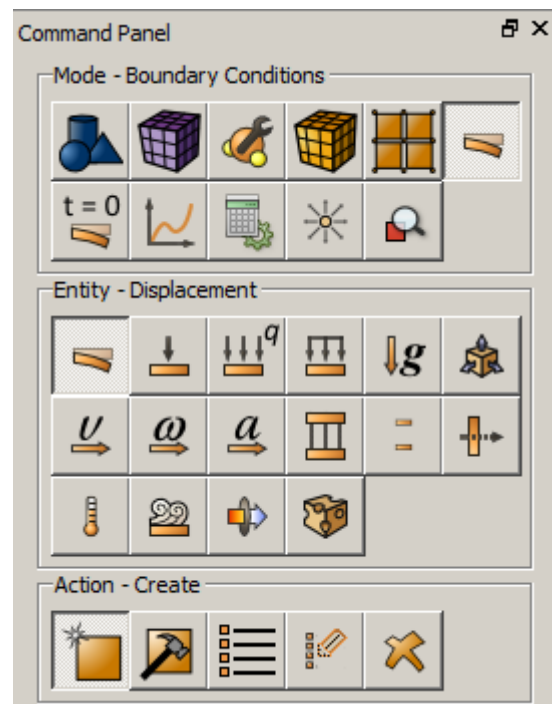

On the command panel, select Mode - **Boundary Conditions**, Entity - **Displacement**, Action - **Create**. Set the following parameters:

- System assigned ID;
- Entity list: Curve;
- Entity ID(s): 4;
- Degrees of freedom: X-Translation Disp;
- DOF Value: 0.

Click **Apply**.

4. Fix curve 1 in the Y direction.

On the command panel, select Mode - **Boundary Conditions**, Entity - **Displacement**, Action - **Create**. Set the following parameters:

- System assigned ID;
- Entity list: Curve;
- Entity ID(s): 1;
- Degrees of freedom: Y-Translation Disp;
- DOF Value: 0.

Click **Apply**.

Set the dependence of the BC on the time and / or coordinates

1. Set the dependence of the BC on the time and / or coordinates.

On the command panel, select Mode – **BC Dependency**.

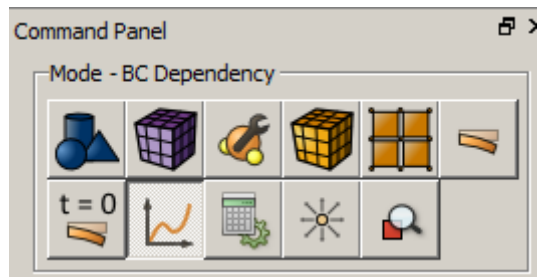

Click **Displacement 3** and choose panel Table in the right side. Set the flag: Time and fill in the table as follows:

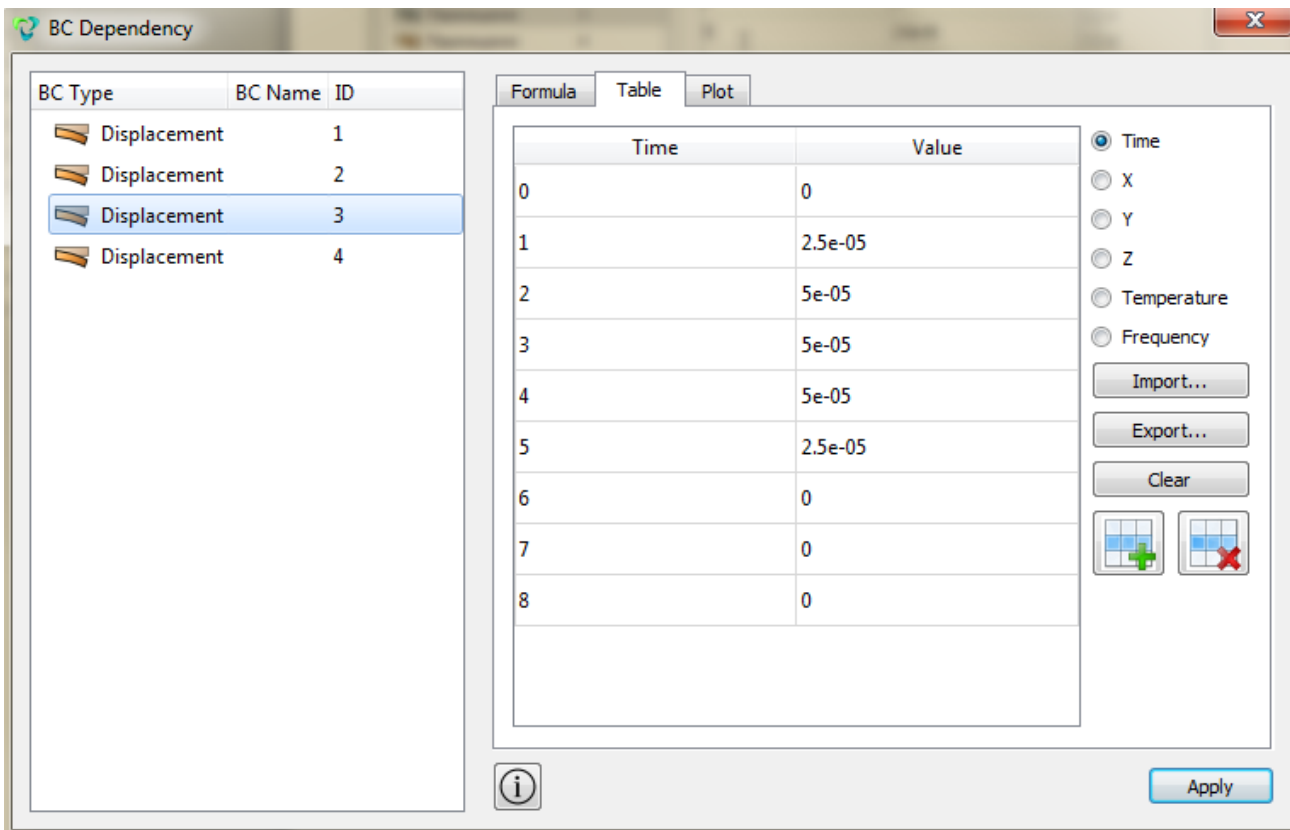

Click **Apply**.

2. Create table 2 for displacement 4.

Click **Displacement 4** and choose panel Table in the right side. Set the flag: Time and fill in the table as follows:

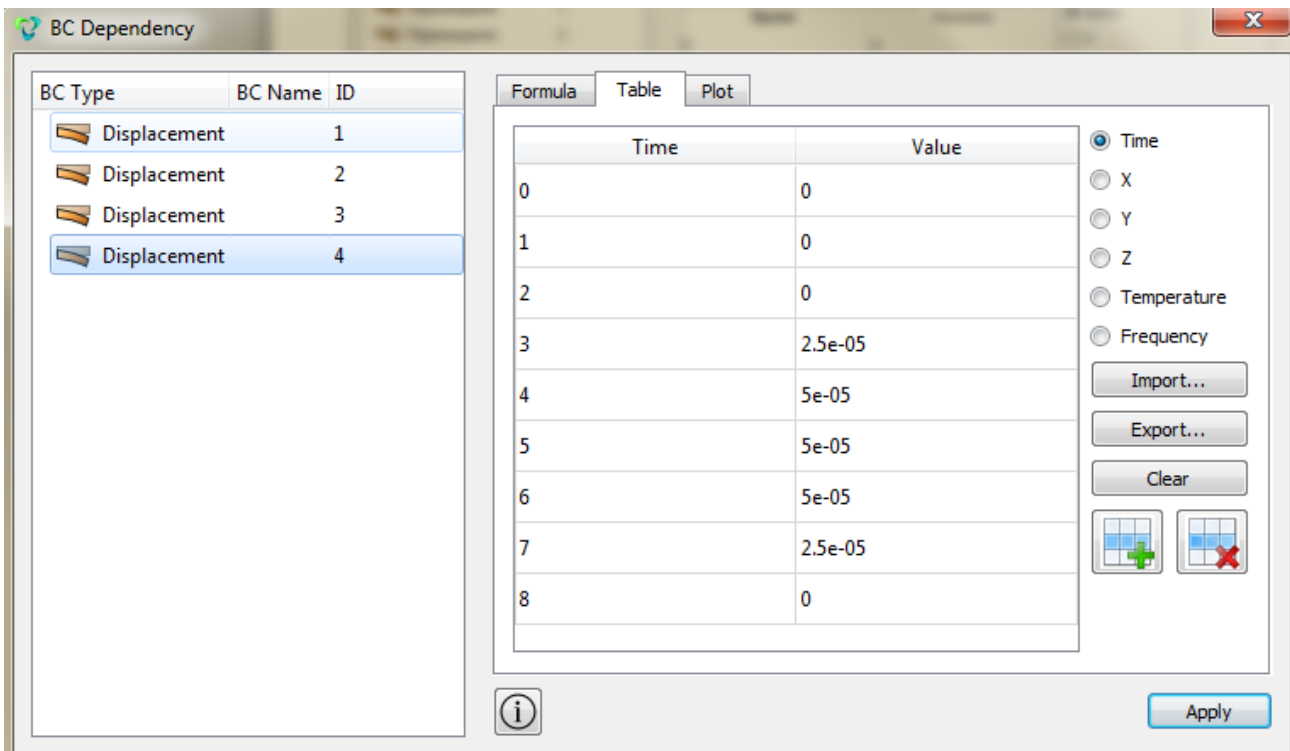

Click **Apply**.

Run calculation

1. Set the type of problem you want to solve.

On the command panel, select the calculation settings module (Mode - **Calculation Settings**, Calculation Settings - **Static**, Static - **General**).

Dimensions: 2D;

Plane state: Plane strain;

Model: Elasticity, Plasticity;

Load steps count: 8.

Click **Apply**.

Click **Start calculation**.

2. In the window that appears, select the directory in which the result will be saved, and enter the file name.
3. In the case of a successful calculation, the console displays the message: "Calculation finished successfully at" date time".

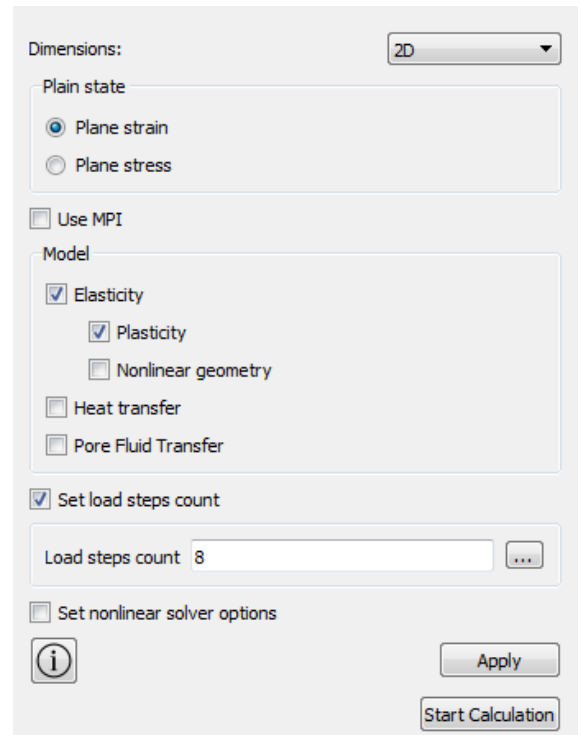

Results analysis

1. Open the file with the results. This can be done in three ways.

Press Ctrl + E.

In the main menu, select **Calculation** → **Open Results**. Click **Open Last Result**.

On the command panel, select a **Results** (Mode - **Results**). Click **Open last Results**.

To analyze the results, go to the **Fidesys Viewer** window.



To automatically apply changes to all filters, click the corresponding button **Apply changes to parameters automatically** on the command bar.

2. Connect the filter to **Warp by vector** (Menu - Filters - Alphabetical Index - Warp by vector). Or use the corresponding button on the command bar:



For this filter, on the Properties tab, set:

- Vector: Displacement;
- Scale multiplier: 10,000;

Click **Apply** (unless **Apply changes to parameters automatically** is enabled).

3. In the top pane, select the payroll result data to display. From the first drop-down list, select **Displacement**, from the second - **Magnitude**.



In the step view panel, set step 1. You should see the plate image in the initial state. Next, click on Play.



. You should see a consistent stretching, and then compression of the plate in accordance with the loading history.

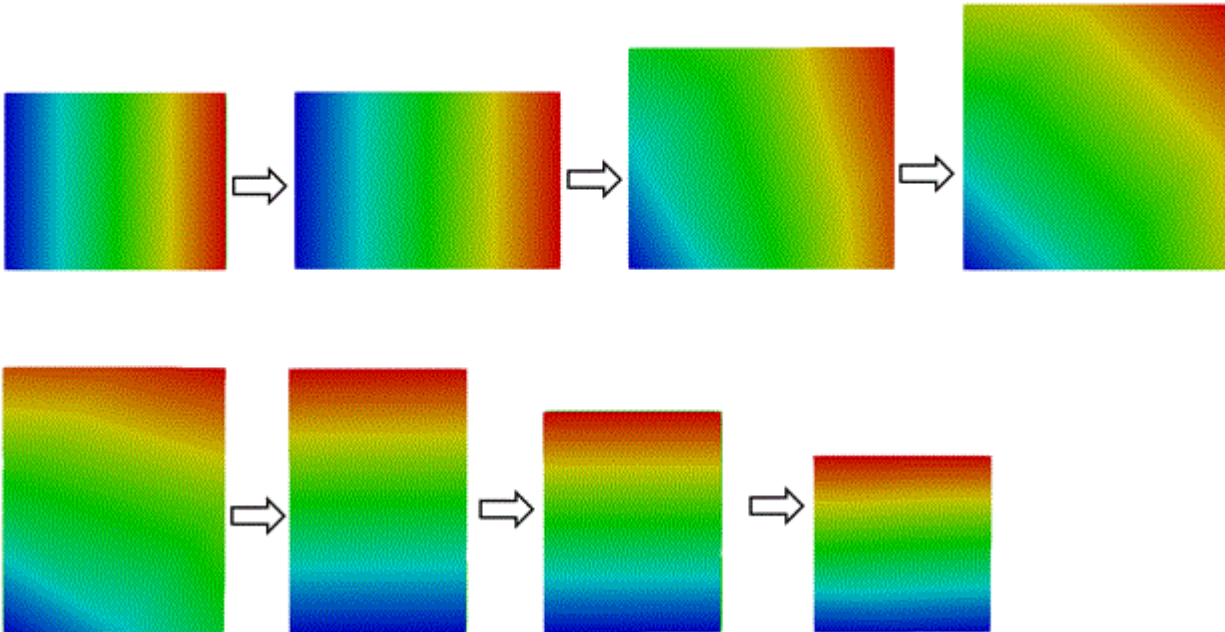

Thus, the calculation of the stress-strain state with the loading history of the plate was made.

Using the console interface

Geometry creating, meshing, setting boundary conditions and materials can be performed using the console interface. Below is the program code that allows you to perform the steps of the above manual, you only need to **specify the full path and name of the saved file.**

```

reset
create surface rectangle width 1 zplane
move surface 1 x 0.5 y 0.5
curve all interval 1
curve all scheme equal
mesh curve all
mesh surface all
create material 1
modify material 1 set property 'MODULUS' value 250e3
modify material 1 set property 'POISSON' value 0.25
modify material 1 set property 'MISES_YIELD_STRENGTH' value 5
block 1 add surface 1
block 1 material 1
block 1 element plane order 2
create displacement on curve 3 dof 2 fix 0
create displacement on curve 2 dof 1 fix 0
create table 1
modify table 1 dependency time
modify table 1 insert row 1
modify table 1 cell 1 1 value 0
modify table 1 cell 1 2 value 0.0
modify table 1 insert row 2
    
```



```
modify table 1 cell 2 1 value 1
modify table 1 cell 2 2 value 2.5e-5
modify table 1 insert row 3
modify table 1 cell 3 1 value 2
modify table 1 cell 3 2 value 5e-5
modify table 1 insert row 4
modify table 1 cell 4 1 value 3
modify table 1 cell 4 2 value 5e-5
modify table 1 insert row 5
modify table 1 cell 5 1 value 4
modify table 1 cell 5 2 value 5e-5
modify table 1 insert row 6
modify table 1 cell 6 1 value 5
modify table 1 cell 6 2 value 2.5e-5
modify table 1 insert row 7
modify table 1 cell 7 1 value 6
modify table 1 cell 7 2 value 0.0
modify table 1 insert row 8
modify table 1 cell 8 1 value 7
modify table 1 cell 8 2 value 0.0
modify table 1 insert row 9
modify table 1 cell 9 1 value 8
modify table 1 cell 9 2 value 0.0
create table 2
modify table 2 dependency time
modify table 2 insert row 1
modify table 2 cell 1 1 value 0
modify table 2 cell 1 2 value 0.0
modify table 2 insert row 2
modify table 2 cell 2 1 value 1
modify table 2 cell 2 2 value 0.0
modify table 2 insert row 3
modify table 2 cell 3 1 value 2
modify table 2 cell 3 2 value 0.0
modify table 2 insert row 4
modify table 2 cell 4 1 value 3
modify table 2 cell 4 2 value 2.5e-5
modify table 2 insert row 5
modify table 2 cell 5 1 value 4
modify table 2 cell 5 2 value 5e-5
modify table 2 insert row 6
modify table 2 cell 6 1 value 5
modify table 2 cell 6 2 value 5e-5
modify table 2 insert row 7
modify table 2 cell 7 1 value 6
modify table 2 cell 7 2 value 5e-5
modify table 2 insert row 8
modify table 2 cell 8 1 value 7
modify table 2 cell 8 2 value 2.5e-5
modify table 2 insert row 9
modify table 2 cell 9 1 value 8
modify table 2 cell 9 2 value 0.0
create displacement on curve 4 dof 1 fix 0
create displacement on curve 1 dof 2 fix 0
bcdep displacement 3 table 1
bcdep displacement 4 table 2
analysis type static elasticity plasticity dim2 planestrain
static steps 8
calculation start path 'D:\CAE-Fidesys-2.0\example.pvd'
```

Sequential addition of volumes in the calculation process

An example of a multi-step calculation in **CAE Fidesys** with the addition of volume in the calculation process is considered. The problem is solved in two steps of loading. At the first step, the model is a brick, one end of which is fixed along the X axis, pressure is applied along the Y axis to the other side (thus, compression occurs). At the second calculation step fixed boundary condition along the X axis for the model is deleted, instead of it a new brick is added to the same face. At the junction, the volumes merged, the opposite side of the new added volume is fixed along the X axis. At the same time, the volumes continue to compress.

Geometry creating

1. Create the first brick.

On the command panel, select the mode for creating volume geometry (Mode - **Geometry**, Entity - **Volume**, Action - **Create**). From the list of geometric primitives, select Brick. Set block sizes:

- X (width): 2;
- Y (height): 1;
- Z (depth): 0.3.

Click **Apply**.

Brick

Brick Dimensions

X (width) 2

Y (height) 1

Z (depth) 0.3

Apply

2. Create a second brick.

On the command panel, select the mode for creating volume geometry (Mode - **Geometry**, Entity - **Volume**, Action - **Create**). From the list of geometric primitives, select Brick. Set block sizes:

- X (width): 1;
- Y (height): 1;
- Z (depth): 0.3.

Click **Apply**.

Move

Volume ID(s) 1

Include Merged

Select Method

To Coordinates To Entity

Distance General Location

In Direction Of Surface Normal

X Distance 1

Y Distance 0.5

Z Distance 0.15

Preview Apply

3. Move the first brick to the origin of CS.

On the command panel, select the mode for creating volume geometry (Mode - **Geometry**, Entity - **Volume**, Action - **Transform**). From the list of possible transformations, select **Move**. Set the parameters:

- Volume ID(s): 1;
- Including Merged: uncheck;
- Select Method: Distance;
- X Distance: 1;
- Y Distance: 0.5;
- Z Distance: 0.15.

Click **Apply**.

4. Move the second brick to the origin of CS.

On the command panel, select the mode for creating volume geometry (Mode - **Geometry**, Entity - **Volume**, Action - **Transform**). From the list of possible transformations, select **Move**. Set the parameters:

- Volume ID(s): 1;
- Including Merged: uncheck;
- Select Method: Distance;
- X Distance: 2.5;
- Y Distance: 0.5;
- Z Distance: 0.15.

Click **Apply**.

5. Merge two volumes.

On the command panel, select the mode for creating volume geometry (Mode - **Geometry**, Entity - **Volume**, Action - **Imprint and Merge**). From the list of possible transformations, select **Merge**. In the **Volume ID(s)** field, enter: all.

Click **Apply**.

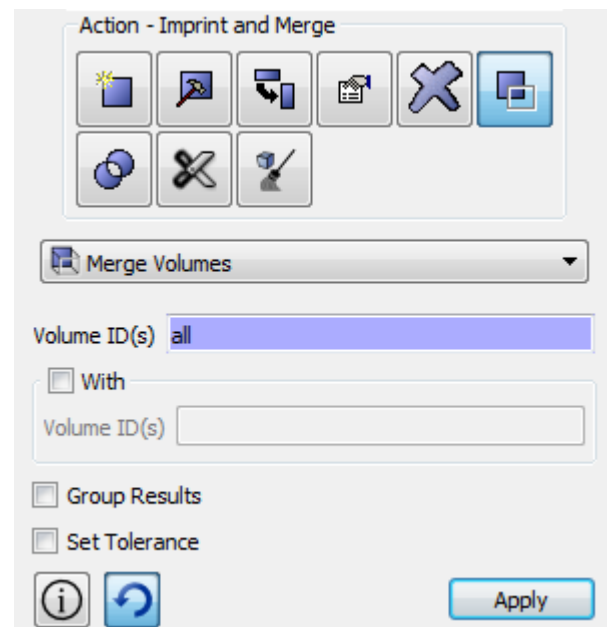

Meshing

- On the command panel, select the volume meshing mode (Mode - **Mesh**, Entity - **Volume**, Action - **Intervals**). Specify the degree of refining mesh:
 - Select Volumes: all;
 - Approximate Size: 0.1.

Click **Apply Size**.

Click **Mesh**.

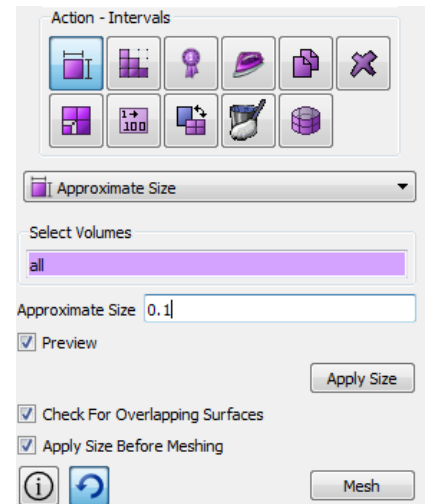

Specifying the material and type of element

- On the command panel, select the mode for setting material properties (Mode - **Material**, Entity - **Materials Management**). Specify the name of the material Material 1. Drag the Hooke Material inscription from the left column into the Material Properties column. Set the following parameters:
 - Young's modulus: 2.1e4;
 - Poisson's ratio: 0.3.

In the left window, go to Plasticity - Mises Criterion and drag the Yield Strength feature into the Material Properties window. Set:

- Yield Strength: 24.

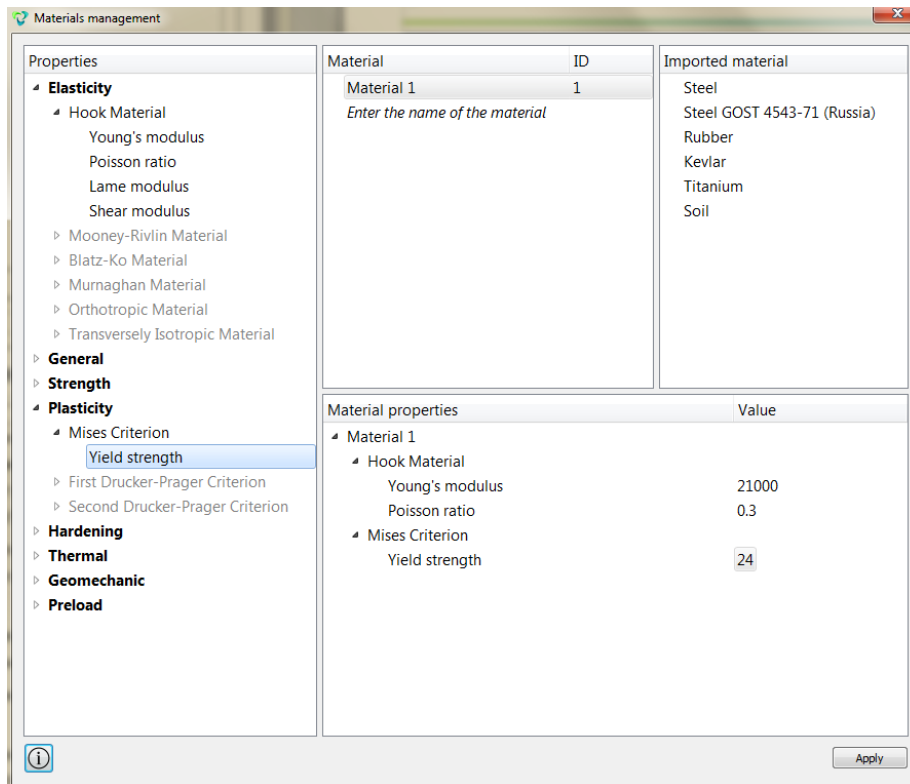

Click **Apply**.

- Create a block.

On the command panel, select the mode for setting material properties (Mode - **Blocks**, Entity - **Block**, Action - **Add**). Set the following parameters:

- Block ID: 1;
- Entity List: Volume;
- Entity ID(s): 1 2 (or the all command).

Click **Apply**.

Block ID 1

Entity List
Volume

Entity ID(s) all

Apply

3. Assign the material to the block.

On the command panel, select the mode for setting material properties (Mode - **Blocks**, Entity - **Block**, Action - **Set Material**). Set the following parameters:

- Block ID (s): 1;
- Select from the list the previously created material: Material 1.

Click **Apply**.

Block ID(s) 1

Available Materials
Material 1

Apply

4. Assign element type and order.

On the command panel, select the mode for setting material properties (Mode - **Blocks**, Entity - **Block**, Action - **Element type**). Set the following parameters:

- Block ID(s): 1;
- Category: Solid;
- Order: 2.

Click **Apply**.

Block ID(s) 1

Category Solid

Order 2

Apply

Setting boundary conditions

1. Fix the model along the Y axis.

On the command panel, select Mode - **Boundary Conditions**, Entity - **Displacement**, Action - **Create**. Set the following parameters:

- System Assigned ID;
- Entity List: Surface;
- Entity ID(s): 3 5 9 11;
- Degrees of Freedom: Y-Translation Disp;
- DOF Value: 0.

Click **Apply**.

2. Fix the model along the X axis.

On the command panel, select Mode - **Boundary Conditions**, Entity - **Displacement**, Action - **Create**. Set the following parameters:

- System Assigned ID;
- Entity List: Surface;
- Entity ID(s): 6;
- Degrees of Freedom: X-Translation Disp;
- DOF Value: 0.

Click **Apply**.

3. Fix the model along the X axis.

On the command panel, select Mode - **Boundary Conditions**, Entity - **Displacement**, Action - **Create**. Set the following parameters:

- System Assigned ID;
- Entity List: Surface;
- Entity ID(s): 12;
- Degrees of Freedom: X-Translation Disp;
- DOF Value: 0.

Click **Apply**.

4. Fix the model along the Z axis.

On the command panel, select Mode - **Boundary Conditions**, Entity - **Displacement**, Action - **Create**. Set the following parameters:

- System Assigned ID;
- Entity List: Surface;
- Entity ID(s): 1 2 7 8;
- Degrees of Freedom: Z-Translation Disp;
- DOF Value: 0.

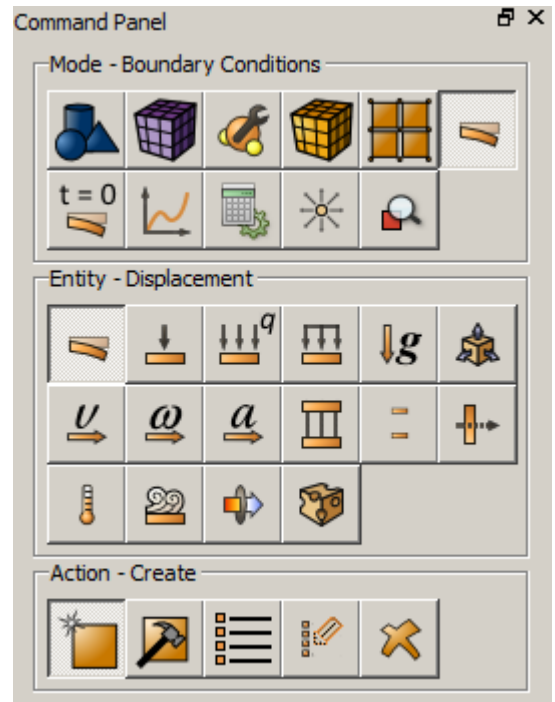

Click **Apply**.

5. Apply pressure 100 MPa to the left side.

On the command panel, select Mode - **Boundary conditions**, Entity - **Pressure**, Action - **Create**. Set the following parameters:

- System Assigned ID;
- Pressure Entity List: Surface;
- Entity ID(s): 4;
- Magnitude Value: 100.

Click **Apply**.

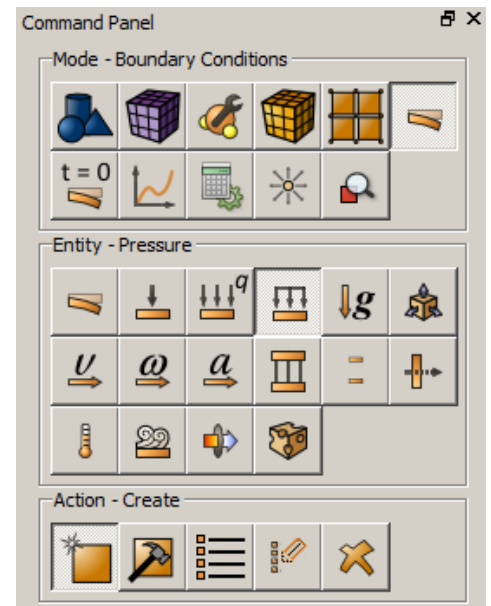

Run calculation

1. Set the type of problem you want to solve.

On the command panel, select the calculation settings mode (Mode - **Calculation Settings**, Calculation Settings - **Static**, Static - **General**).

- Dimension: 3D;
- Model: Elasticity, Plasticity;
- Load steps count: 2.

Click **Apply**.

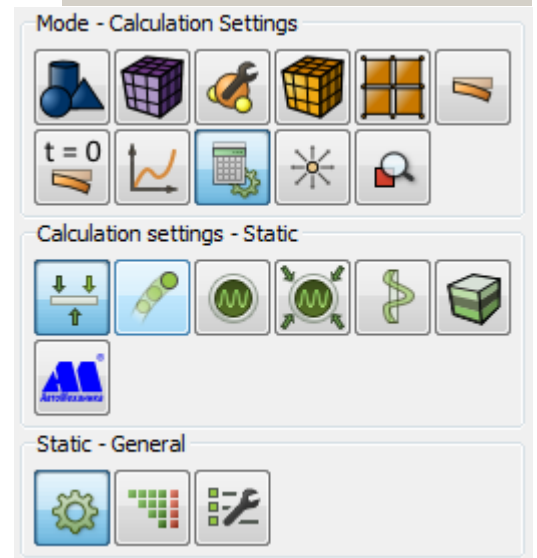

2. Go to the Settings window load steps.

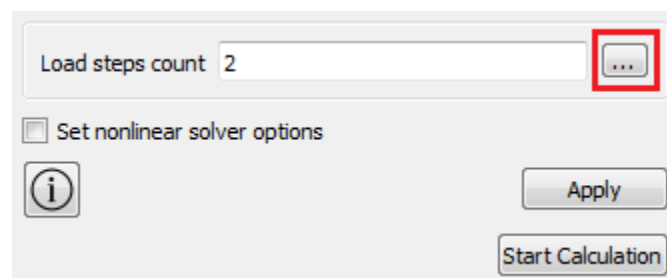

Set step calculation – 1 for displacement 2. Boundary condition will be active in this step.

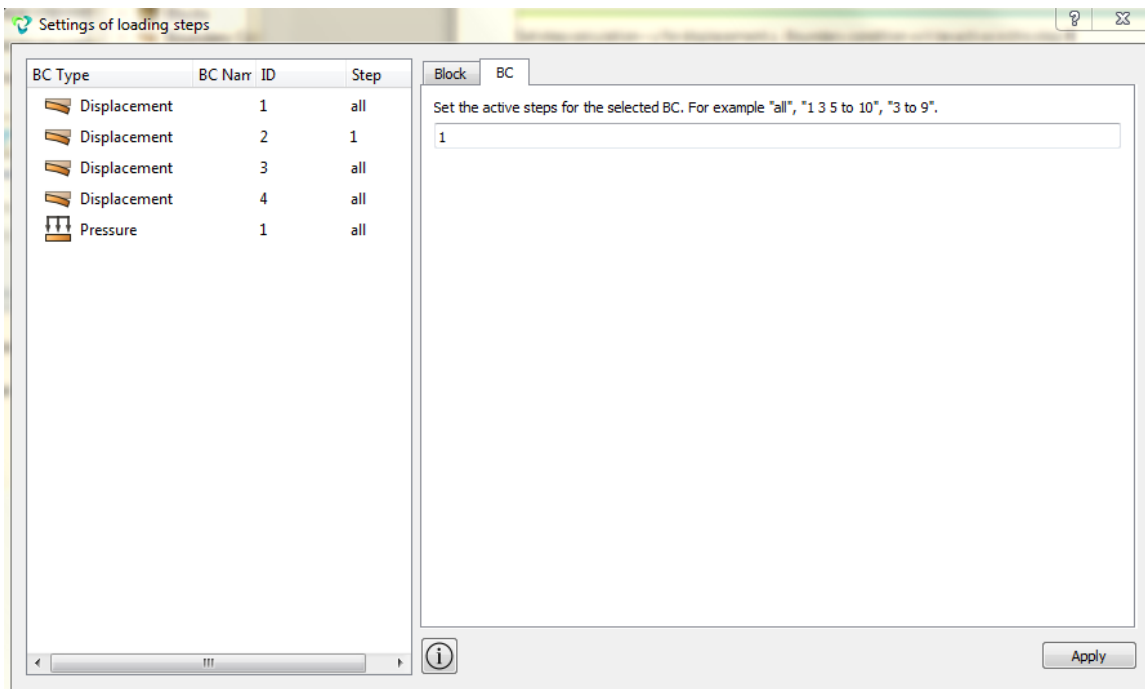

Click **Apply**.

3. In the setting load steps window, select block 2 and set at which calculation step this block will be active.

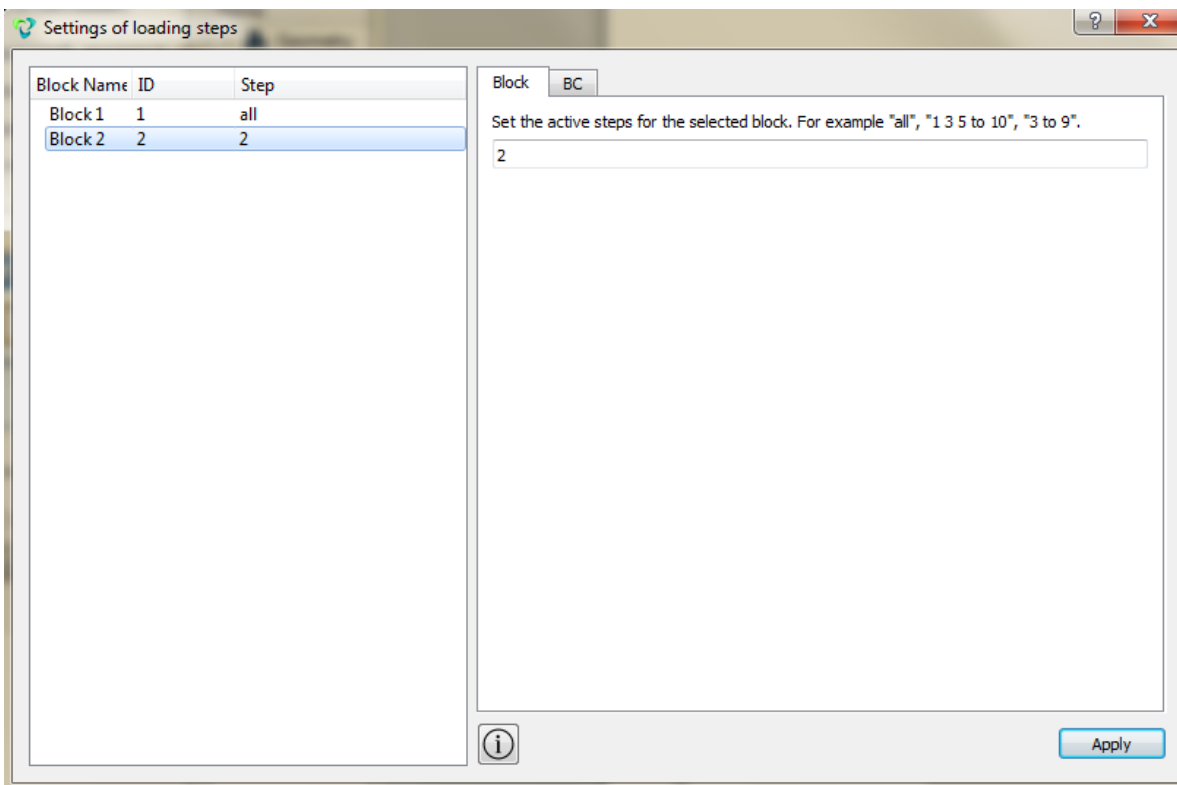

Click **Apply**.

Click **Start calculation**.

4. In the window that appears, select the directory in which the result will be saved, and enter the file name.

5. In the case of a successful calculation, the console displays the message: Calculation finished successfully at "date time".

Result Analysis

1. Open the file with the results. This can be done in three ways.
 - Press Ctrl + E.
 - From the main menu, select **Calculation** → **Results**. Click **Open Last Result**.

For postprocessor analysis, go to the **Fidesys Viewer** window.

2. Connect the filter **Warp by Vector** (Menu - Filters – Alphabetical - Warp by Vector). Or use the corresponding button on the command bar:



For this filter, on the Properties tab, set:

- Vector: Displacement;
 - Scale factor: 100;
 - Click Apply.
3. On the top bar, select the required result data to display. From the first drop-down list, select **Displacement**, from the second - **Magnitude**, from the third - **Surface with edges**.



4. In the step view panel, set step 1. You should see the image in the initial state. Next, click on Play . You should see the sequential compression of the model in accordance with the loading history.

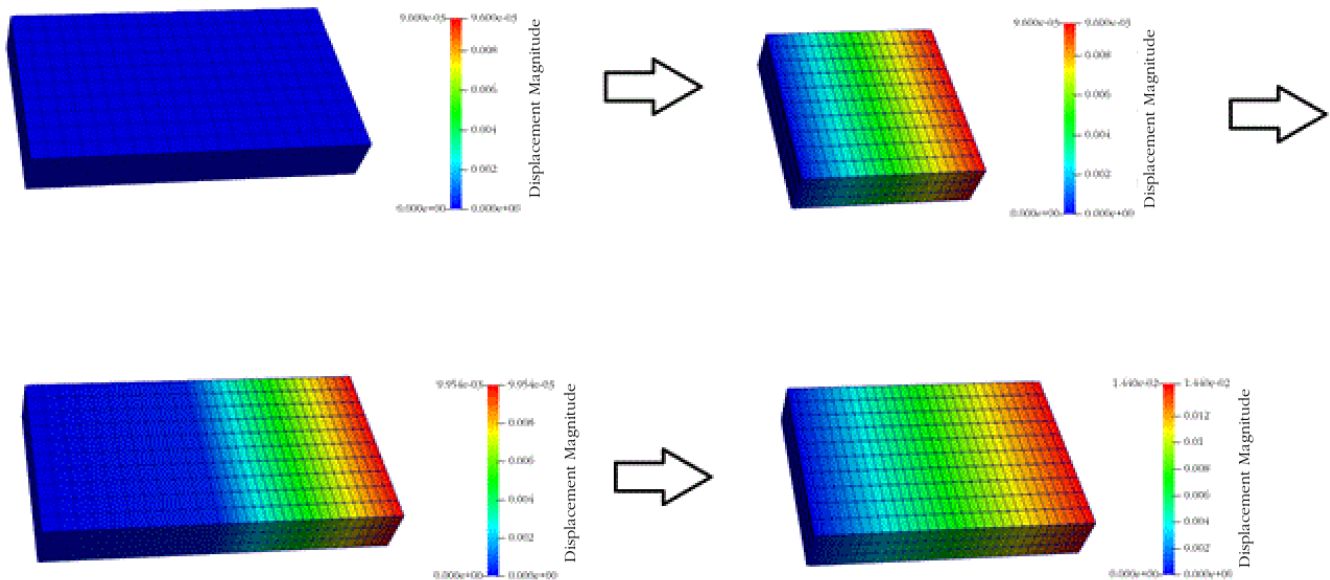

Using the console interface

Geometry creating, meshing, setting boundary conditions and materials can be performed using the console interface. Below is the program code that allows you to perform the steps of the above manual. You need only to specify the full path and name of the saved file.

```

reset
#{width1 = 2}
#{width2 = 1}
#{heightY = 1}
#{heightZ = 0.3}
create brick x {width1} y {heightY} z {heightZ}
create brick x {width2} y {heightY} z {heightZ}
move volume 1 x {width1/2} y {heightY/2} z {heightZ/2}
move volume 2 x {width1 + width2/2} y {heightY/2} z {heightZ/2}
merge all
create material 1
modify material 1 set property 'POISSON' value 0.3
modify material 1 set property 'MODULUS' value 2.1e+04
modify material 1 set property 'MISES_YIELD_STRENGTH' value 24
block 1 volume 1
block 2 volume 2
block all material 1#присвойте материал блоку
block all element solid order 2
surface all size {heightY/10}
mesh volume all
create displacement 1 on surface 3 5 9 11 dof 2 fix
create displacement 2 on surface 6 dof 1 fix
create displacement 3 on surface 12 dof 1 fix
create displacement 4 on surface 1 2 7 8 dof 3 fix
create pressure on surface 4 magnitude 100
analysis type static elasticity plasticity dim3
static steps 2
bcdep displacement 2 step 1
block 2 step 2
calculation start path "d:\Fidesys\result.pvd"
    
```

Sequential deletion of volumes in the calculation process

The model is a cylindrical tube consisting of three layers. Material parameters for all three layers: $E = 2.1e4 \text{ N / mm}^2$, $\nu = 0.3$, yield strength $c = 24 \text{ N / m}^2$. A uniform pressure of 14 N / mm^2 is applied to the inner surface of the pipe. Fixation according with the symmetry condition. Three loading steps are specified: in the second step, the outer layer of the pipe is removed, in the third step, the next outer layer of the pipe is removed. In the process of solution, stresses are analyzed with the plastic flow and pipe thinning.

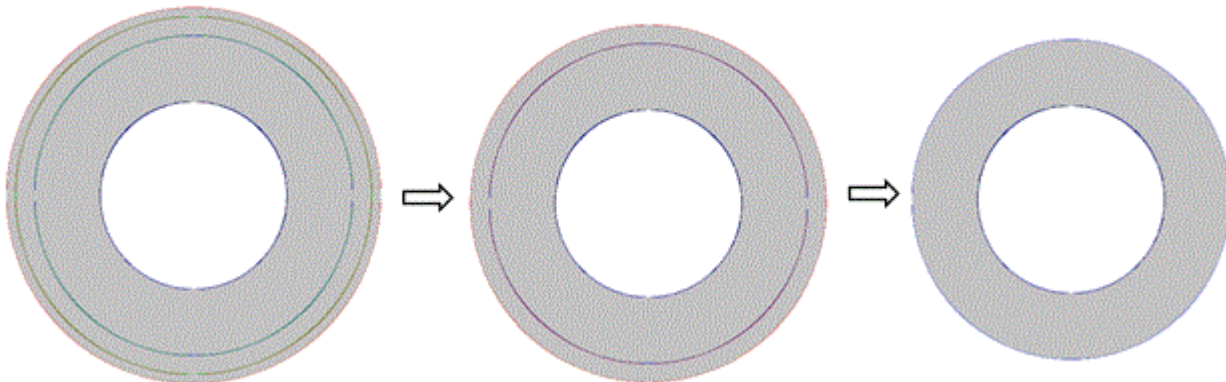
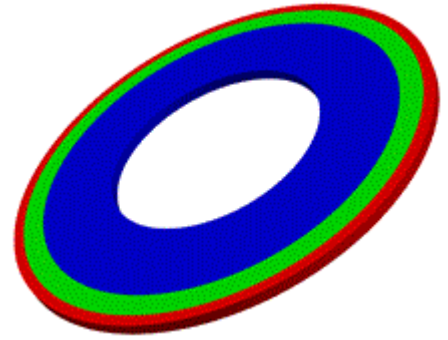

Geometry creating

1. Create a circular surface with a radius of 100.

On the command panel, select the mode for creating volume geometry (Mode - **Geometry**, Entity - **Surface**, Action - **Create**). From the list of geometric primitives, select Circle. Set the dimensions:

- Radius: 100;
- Location: Z-plane.

Click **Apply**.

2. Create a circular surface with a radius of 170.

Set the dimensions:

- Radius: 170;
- Location: Z-plane.

Click **Apply**.

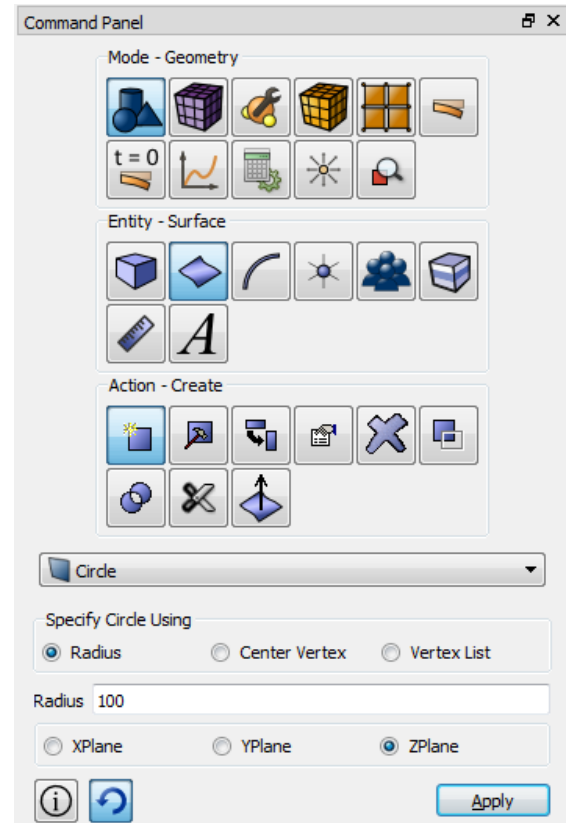

3. Create a circular surface with a radius of 190.

Set the dimensions:

- Radius: 190;
- Location: Z-plane.

Click **Apply**.

4. Create a circular surface with a radius of 200.

Set the dimensions:

- Radius: 190;
- Location: Z-plane.

Click **Apply**.

5. Subtract surface 1 from the remaining surfaces 2 3 4.

On the command panel, select the mode for creating volume geometry (Mode - **Geometry**, Entity - **Surface**, Action - **Boolean**). From the list of operations, select **Subtract**. Set the following parameters:

- Surface ID (s): 2 3 4 (surfaces from which other surface will be subtracted);
- Surface ID (s): 1 (surfaces to be subtracted).

Click **Apply**.

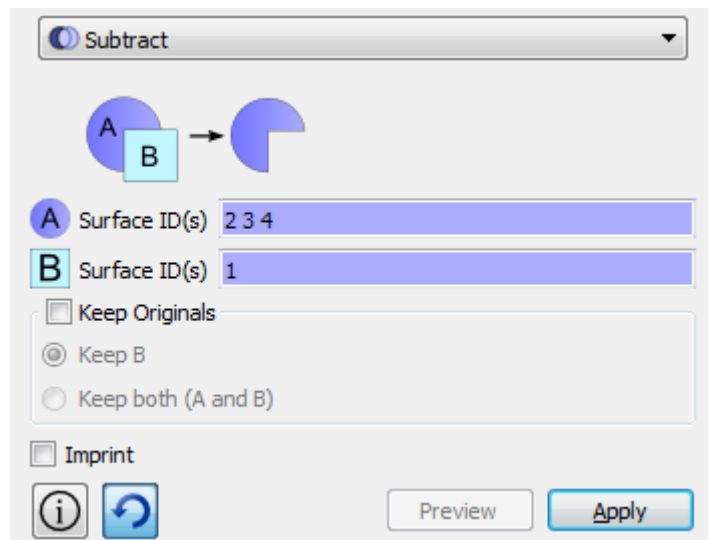

6. Subtract surface 5 from surface 6.

On the command panel, select the mode for creating volume geometry (Mode - **Geometry**, Entity - **Surface**, Action - **Boolean**). From the list of operations, select **Subtract**. Set the following parameters:

- Surface ID (s): 6 (surfaces from which other surface will be subtracted);
- Surface ID (s): 5 (amounts to be deducted);
- Check the Keep Originals box and select Keep both (A and B).

Click **Apply**.

7. Subtract surface 6 from surface 7.

On the command panel, select the mode for creating volumetric geometry (Mode - **Geometry**, Entity - **Surface**, Action - **Boolean**). From the list of operations, select **Subtract**. Set the following parameters:

- Surface ID (s): 6 (surfaces from which other surface will be subtracted);
- Surface ID (s): 7 (surfaces to be subtracted).

Click **Apply**.

8. Cut the body.

On the command panel, select the mode for creating volumetric geometry (Mode - **Geometry**, Entity - **Surface**, Action - **Webcut**). From the list of possible types of cuts, select **Coordinate Plane**. Set the following parameters:

- Body ID(s): all (the surfaces to be cut);
- Cut: Plane YZ;
- Offset value: 0.

Click **Apply**.

Do the same, but in the ZX plane:

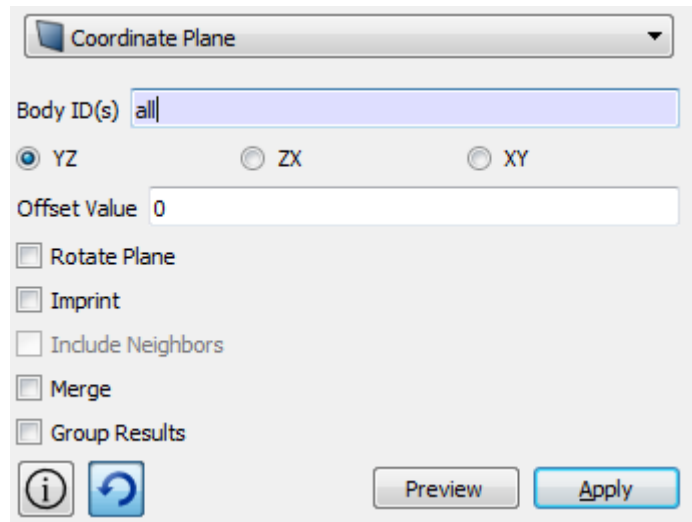

On the command panel, select the mode for creating volumetric geometry (Mode - **Geometry**, Entity - **Surface**, Action - **Webcut**). From the list of possible types of cuts, select **Coordinate Plane**. Set the following parameters:

- Body ID(s): all (the surfaces to be cut);
- Cut: Plane ZX;
- Offset value: 0.

Click **Apply**.

9. Delete the surface.

On the command panel, select the mode for constructing volumetric geometry (Mode - **Geometry**, Entity - **Surface**, Action - **Delete**). In the Volume ID field, enter the numbers - 16 20 24 17 21 25 19 23 27.

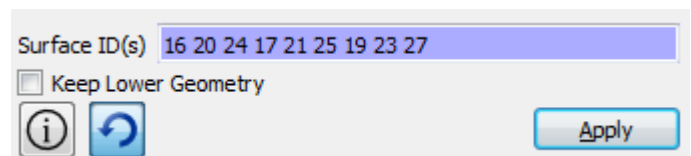

10. Draw a surface to create volume:

On the command panel (Mode - **Geometry**, Entity - **Volume**, Action - **Create**). From the list of geometric primitives, select **Sweep**. Set the following parameters:

- Surface ID (s): all;
- Perpendicular;
- Distance: 10.

Click **Apply**.

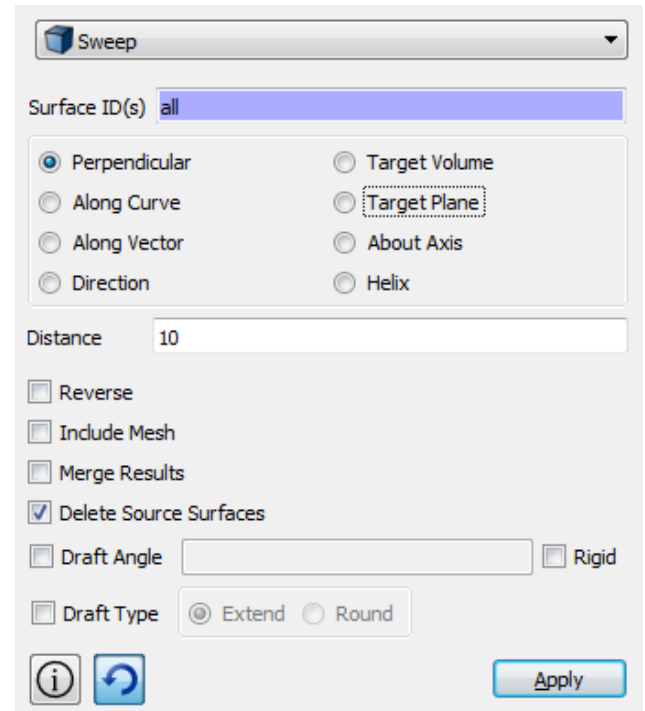

Meshing

1. On the command panel, select the mesh generation mode on curves (Mode - **Mesh**, Entity - **Curve**, Action - **Mesh**). Specify the degree of refining mesh:

- Curve selection: 71 76 79 87 (through spaces);
- Select the mesh generation method: Equal;
- Select the partitioning options: Interval;
- Interval: 50 (see picture).

Click **Apply**.

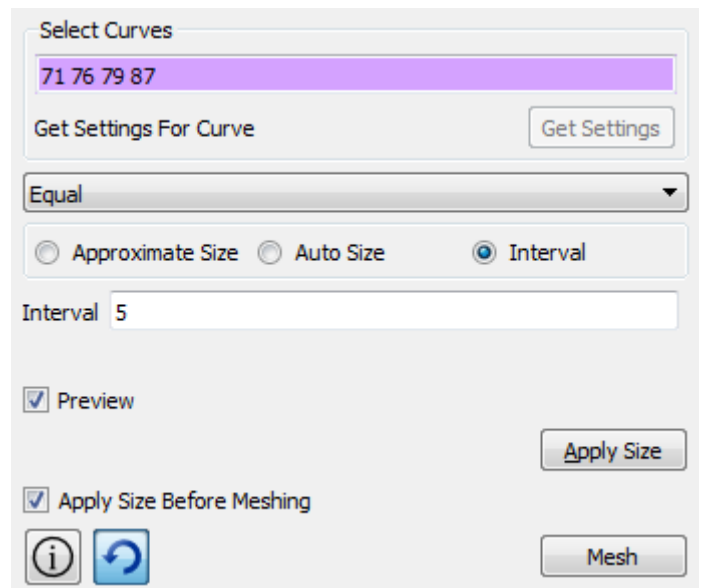

2. On the command panel, select the mesh generation module on curves (Mode - **Mesh**, Entity - **Curve**, Action - **Mesh**). Specify the degree of refining mesh:

- Select Curves: 74 82 90 78 86 94 (through spaces);
- Select the meshing method: Equal;
- Select the partitioning options: Approximate size;
- Approximate size: 2.

Click **Apply**.

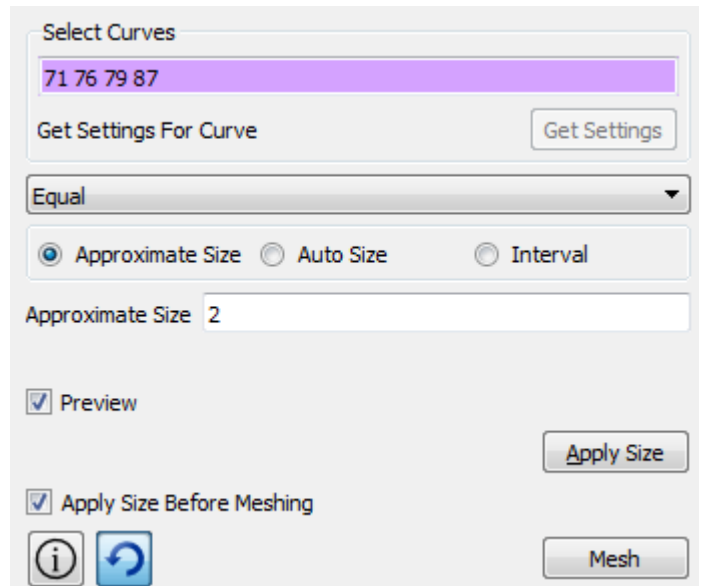

3. On the command panel, select the mesh generation module on curves (Mode - Mesh, Entity - Curve, Action - Mesh). Specify the degree of refining mesh:

- Select Curves: 75 72 80 88 77 73 81 89 (through spaces);
- Select the meshing method: Evenly;
- Select the partitioning options: Interval;
- Interval: 1 (see picture).

Click **Apply**.

4. On the command panel, select the mesh generation module on the planes (Mode - **Mesh**, Entity - **Volume**, Action - **Intervals**). Specify the mesh spacing:

- Select Volumes: all;
- Select the meshing mode: Automatic Sizing.

Click **Apply Size**.

Click **Mesh**.

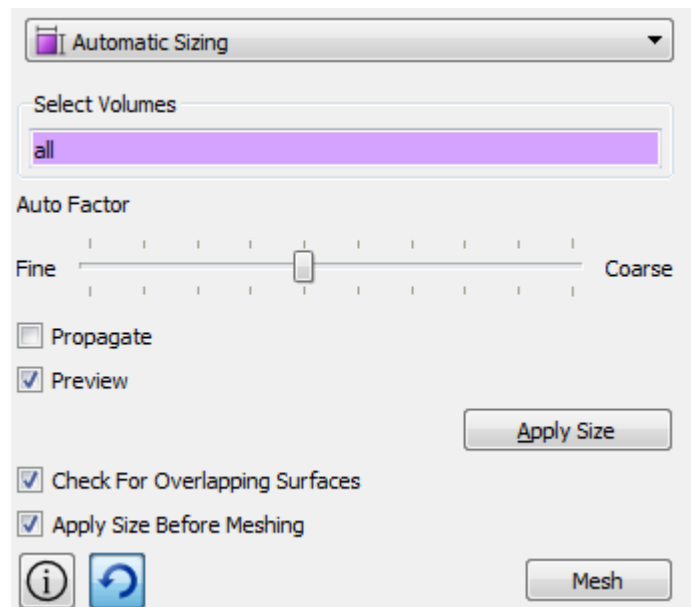

Set the Material

- On the command panel, select the module for setting material properties (Mode - **Material**, Entity - **Materials Management**). Specify the name of the material material 1.



- Drag the Hooke Material inscription from the left column, as well as, under the Mises inscription, in the Plasticity section, in the Material Properties column. Set the following parameters:
 - Young's modulus: $2.1e + 04$;
 - Poisson's ratio: 0.3.

In the left window, go to Plasticity - According to Mises and drag the Yield Strength feature into the Material Properties window. Set:

- Yield strength: 24.

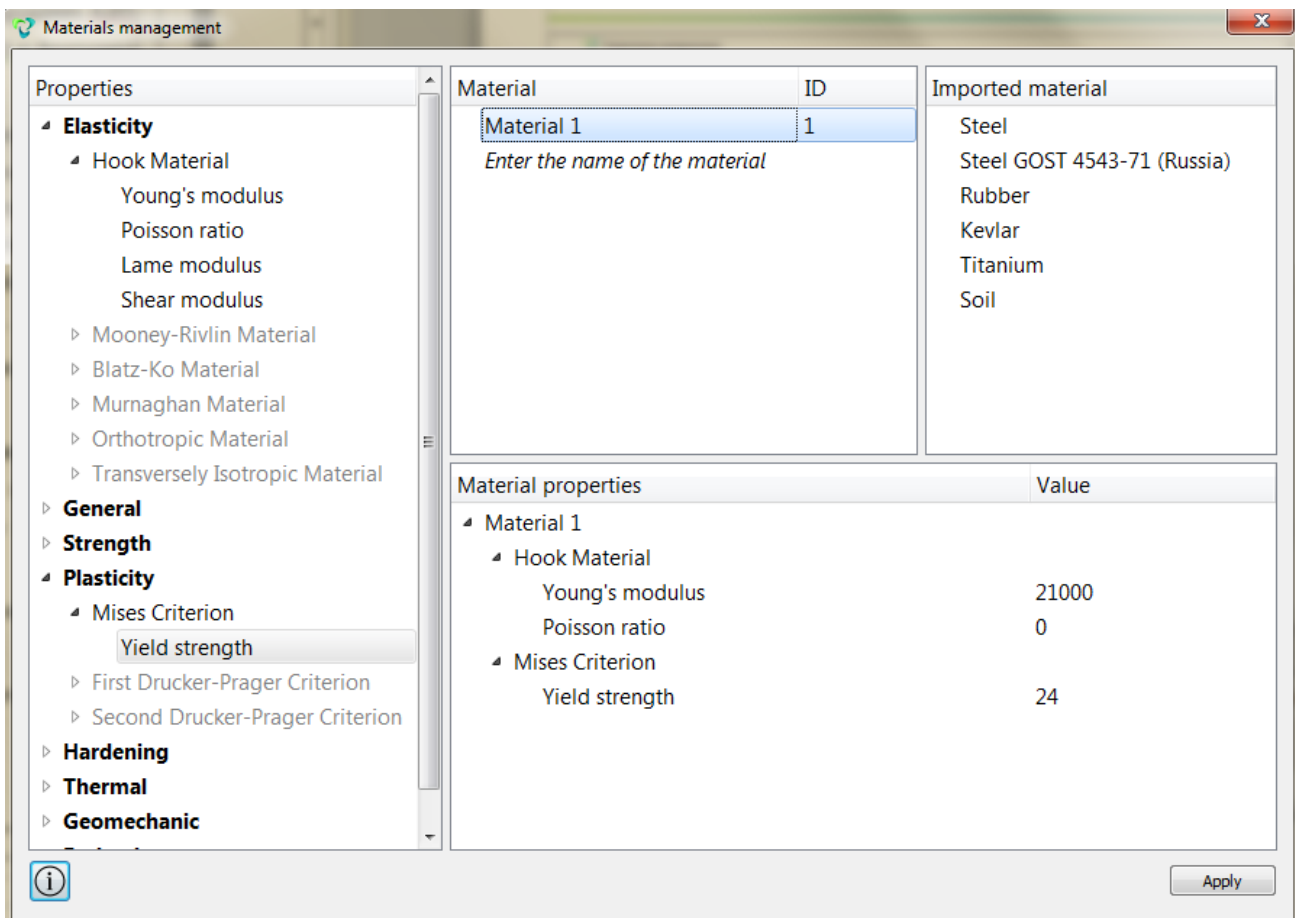

Click **Apply**.

Setting boundary conditions

1. On the command panel, select Mode - **Boundary Conditions**, Entity - **Displacement**, Action - **Create**. Set the following parameters:

- System Assigned ID;
- Entity List: Surface;
- Entity ID(s): 29 34 39;
- Degrees of Freedom: Y-Translation Disp;
- DOF Value: 0.

Click **Apply**.

2. On the command panel, select Mode - **Boundary Conditions**, Entity - **Displacement**, Action - **Create**. Set the following parameters:

- System Assigned ID;
- Entity List: Surface;
- Entity ID(s): 31 26 41;
- Degrees of Freedom: X-Translation Disp;
- DOF Value: 0.

Click **Apply**.

3. On the command panel, select Mode - **Boundary Conditions**, Entity - **Displacement**, Action - **Create**. Set the following parameters:

- System Assigned ID;
- Entity List: Surface;
- Entity ID(s): 32 37 42 18 22 26;
- Degrees of Freedom: Z-Translation Disp;
- DOF Value: 0.

Click **Apply**.

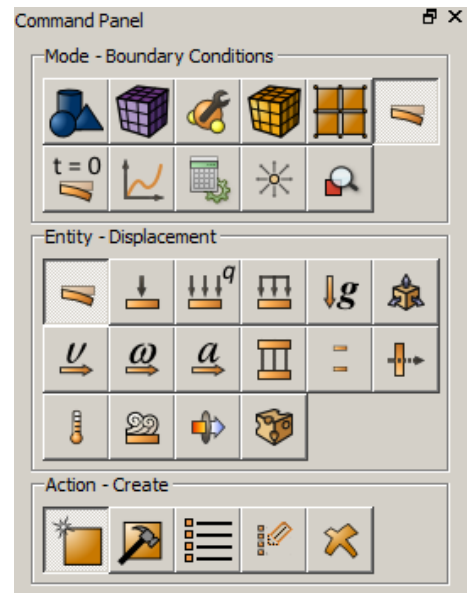

4. Apply uniform pressure to the surface.

On the command panel, select Mode - **Boundary Conditions**, Entity - **Pressure**, Action - **Create**. Set the following parameters:

- System Assigned ID;
- Pressure Entity List: Surface;
- Entity ID(s): 30;
- Magnitude Value: 14.

Click **Apply**.

The screenshot shows the 'Pressure' command panel with the following settings:

- ID/Name:** System Assigned ID (selected)
- Pressure Entity List:** Surface (selected), Curve, Sideset, Tri, Face/Quad, Edge
- Entity ID(s):** 30
- Magnitude Value:** 14
- Interpret Value As:** Use Pure Pressures (selected), Interpret Value As, Use Total Force
- Apply Pressure On:** Top (selected), Bottom

Buttons: Information (i), Refresh (circular arrow), and Apply.

Set the material and element type

1. Create block of one type of material.

On the command panel, select the module for setting material properties (Mode - **Blocks**, Entity - **Block**, Action – **Add**). Set the following parameters:

- Block ID: 1;
- Entity List: Volume;
- Entity ID(s): 6.

Click **Apply**.

The screenshot shows the 'Block' command panel with the following settings:

- Block ID:** 1
- Entity List:** Volume
- Entity ID(s):** 6

Buttons: Information (i) and Apply.

2. Create a second block.

On the command panel, select the module for setting material properties (Mode - **Blocks**, Entity - **Block**, Action – **Add**). Set the following parameters:

- Block ID: 2;
- Entity List: Surface;
- Entity ID (s): 7.

Click **Apply**.

3. Create the third block.

On the command panel, select the module for setting material properties (Mode - **Blocks**, Entity - **Block**, Action – **Add**). Set the following parameters:

- Block ID: 3;
- Entity List: Surface;
- Entity ID (s): 8.

Click **Apply**.

4. Assign the material to the blocks.

On the command panel, select the module for setting material properties (Mode - **Blocks**, Entity - **Block**, Action - **Set Material**). Set the following parameters:

- Block ID (s): all;
- Select from the list the previously created material: Material 1.

Click **Apply**.

Block ID(s) 1

Available Materials

Material 1

Apply

5. Assign an element type.

On the command panel, select the module for setting material properties (Mode - **Blocks**, Entity - **Block**, Action - **Element type**). Set the following parameters:

- Block ID(s): all;
- Category: Solid;
- Order: 2.

Click **Apply**.

Block ID(s) all

Category Solid

Order 2

Apply

Run calculation

1. Set the type of problem you want to solve.

On the command panel, select the calculation settings module (Mode - **Calculation Settings**, Calculation Settings - **Static**, Static - **General**).

- Dimensions: 2D;
- Plane state: Plane strain;
- Model: Elasticity, Plasticity;
- Load steps count: 3.

Mode - Calculation Settings

Calculation settings - Static

Static - General

Dimensions: 2D

Plain state

Plane strain
 Plane stress

Use MPI

Model

Elasticity
 Plasticity
 Nonlinear geometry
 Heat transfer
 Pore Fluid Transfer

Set load steps count

Load steps count 3

Set nonlinear solver options

Apply

Start Calculation

Click on the three dot icon  in order to configure the active calculation steps for block 2 - 1 2 (separated by spaces), and for block 3 - 1.

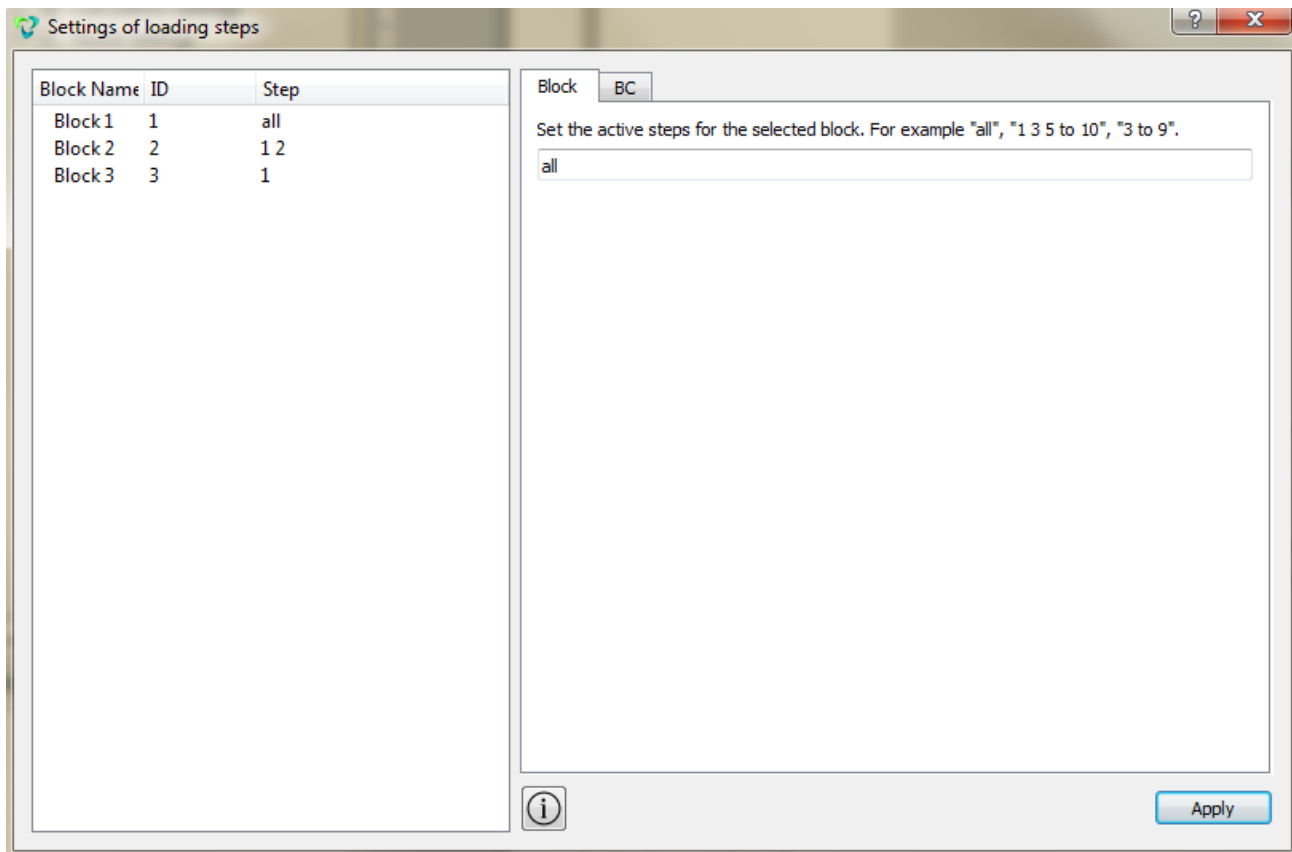

Click on the **Apply, Start Calculation** command bar.

2. In the window that appears, select the directory in which the result will be saved, and enter the file name.
3. In the case of a successful calculation, the console displays the message: Calculation finished successfully at "date time".

Result Analysis

1. Open the file with the results. This can be done in three ways.
 - Press Ctrl + E.
 - From the main menu, select **Calculation** → **Results**. Click **Open Last Result**.

For postprocessor analysis, go to the **Fidesys Viewer** window.

2. In the top pane, select the required result data to display. From the first drop-down list, select **Stress**, from the second - **Mises**, from the third - **Surface**.



3. In the step view panel, set step 1. You should see the image in the initial state. Next, click on Play .

You should see the sequential removal of layers on the model according to the loading history.

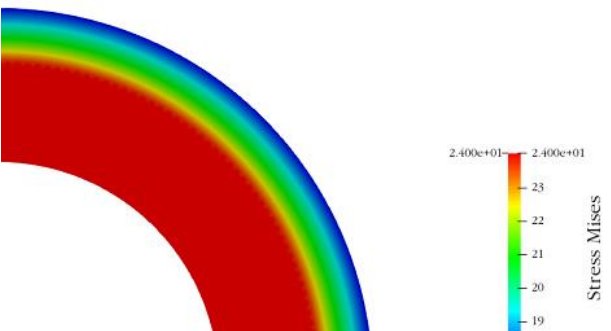
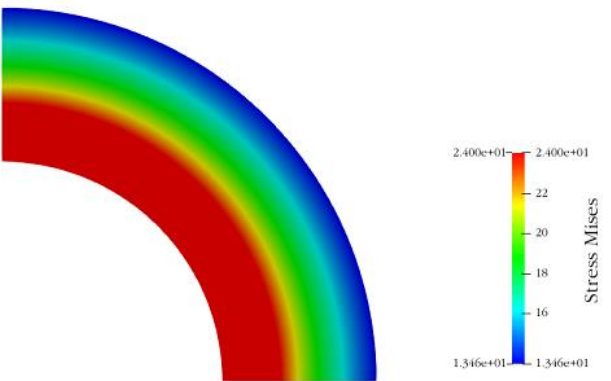
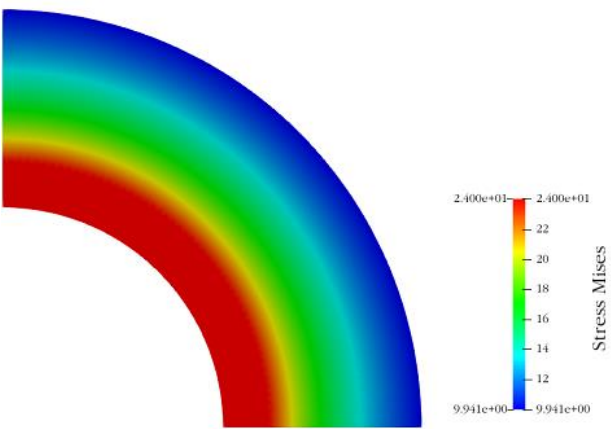
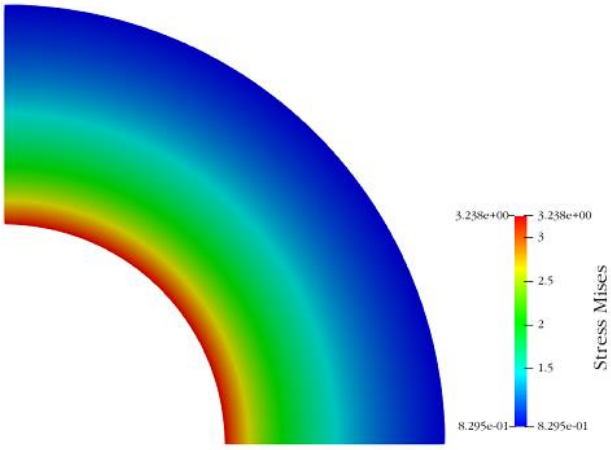

Using the console interface

Geometry generation, meshing, setting boundary conditions and materials can be performed using the console interface. Below is the program code that allows you to perform the steps of the above manual, you only need to **specify the full path and name of the saved file**.

```
#delete layers
#сравнение с Abaqus
#{rInner = 100}
#{rOuter1 = 170}
#{rOuter2 = 190}
#{rOuter3 = 200}
reset
create surface circle radius {rInner} zplane
create surface circle radius {rOuter1} zplane
create surface circle radius {rOuter2} zplane
create surface circle radius {rOuter3} zplane
subtract surface 1 from surface 2 3 4
subtract surface 5 from surface 6 keep
subtract surface 6 from surface 7
webcut surface all with plane yplane offset 0
webcut surface all with plane xplane offset 0
delete surface 16 20 24 17 21 25 19 23 27
sweep surface all perpendicular distance 10 merge
create material 1
modify material 1 set property 'POISSON' value 0.3
modify material 1 set property 'MODULUS' value 2.1e+04
modify material 1 set property 'MISES_YIELD_STRENGTH' value 24
create displacement on surface 29 34 39 dof 2 fix
create displacement on surface 31 36 41 dof 1 fix
create displacement on surface 32 37 42 18 22 26 dof 3 fix
create pressure on surface 30 magnitude 14 #10, 12, 14
block 1 volume 6 #inner - all steps
block 2 volume 7 #medium - steps 1,2
block 3 volume 8 #outer - step 1
block all material 1
block all element solid order 2
curve 71 76 79 87 interval 50
curve 74 82 90 78 86 94 size 2
curve 75 72 80 88 77 73 81 89 interval 1
mesh volume all
analysis type static elasticity plasticity dim3
nonlinearopts maxiters 100 minloadsteps 10 maxloadsteps 30 tolerance 1e-5
static steps 3
block 2 step 1, 2
block 3 step 1
#output iterresults on
calculation start path "d:\Fidesys\result.pvd"
```

Seismic wave propagation (SEG-Y results)

CAE Fidesys allows you to upload solution results in SEG-Y format. This example considers the propagation of seismic waves in the ground based on the Boussinesq problem for a 2D case. The procedures for setting receivers, saving and subsequent analysis of data in the SEG-Y format are demonstrated.

The model is a part of the plane (xy), a point force is applied to vertex. Non-reflective boundary conditions are applied.

Geometry creating

1. Create a square plate.

On the command panel, select the mode for creating volume geometry (Mode - **Geometry**, Entity - **Surface**, Action - **Create**). From the list of geometric primitives, select **Rectangle**. Set block sizes:

- Width: 10000;
- Location: ZPlane.

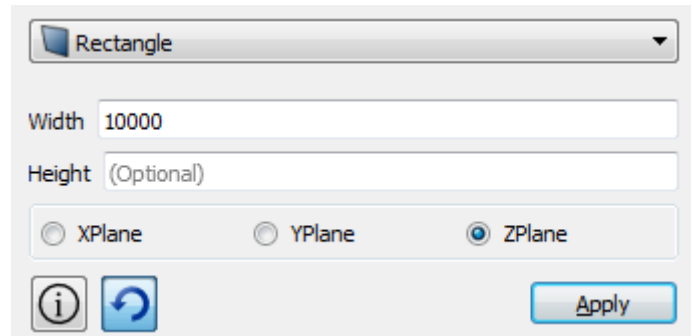

Click **Apply**.

2. Due to symmetry, we consider half of the model.

On the command panel, select the mode for creating volume geometry (Mode - **Geometry**, Entity - **Surface**, Action - **Webcut**). From the list of possible kind of webcuts, select **Coordinate Plane**. Set the following parameters:

- Body ID(s): 1 (the body to be cut);
- Cut: YZ;
- Offset Value: 0.

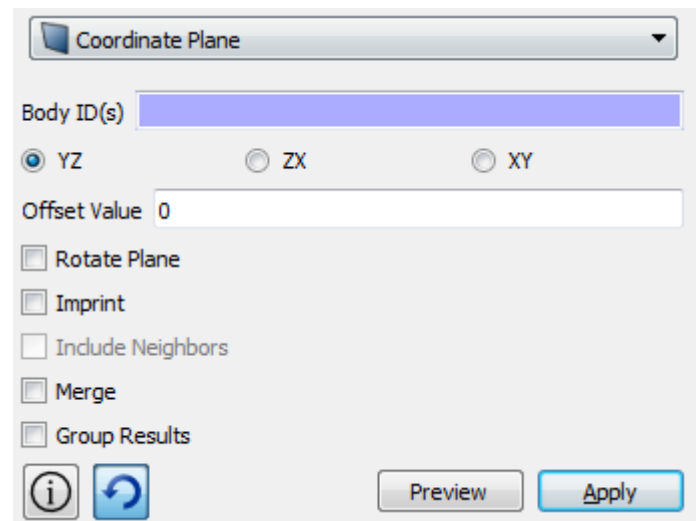

Click **Apply**.

Do the same, but in the ZX plane.

- Body ID(s): 1 (the body to be cut);
- Cut: ZX;
- Offset value: 0.

Click **Apply**.

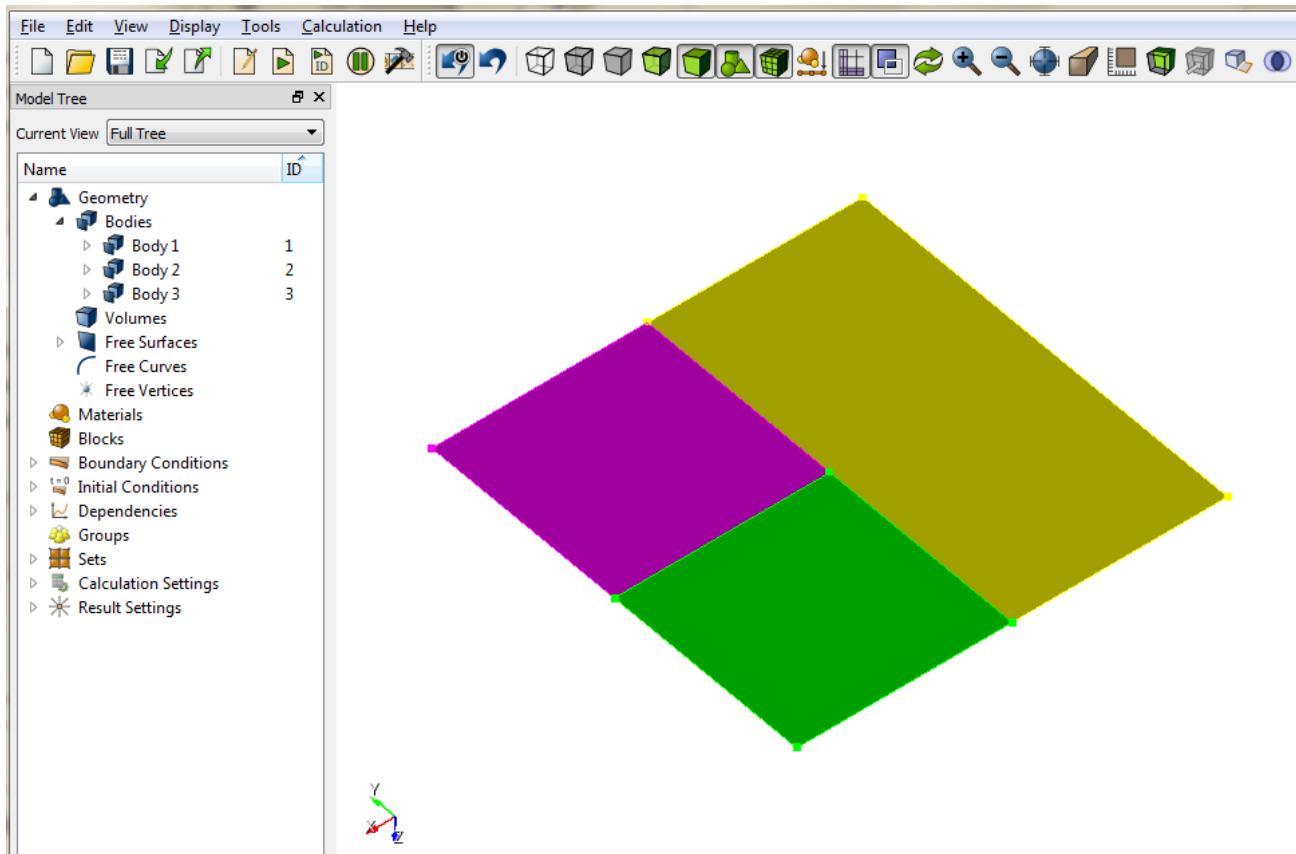

As a result, the original Body 1 in the Model Tree will be divided into three bodies (Body 1, Body 2 and Body 3).

3. Delete Surface 3.

On the command panel, select the mode for creating volume geometry (Mode - **Geometry**, Entity - **Surface**, Action - **Delete**). Set the parameters:

- Surface ID (s): 3.

Click **Apply**.

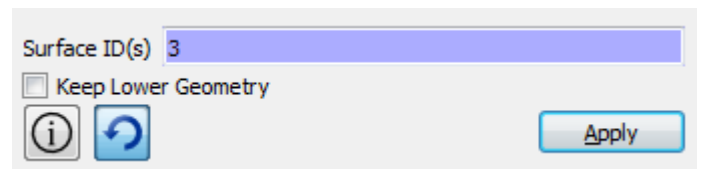

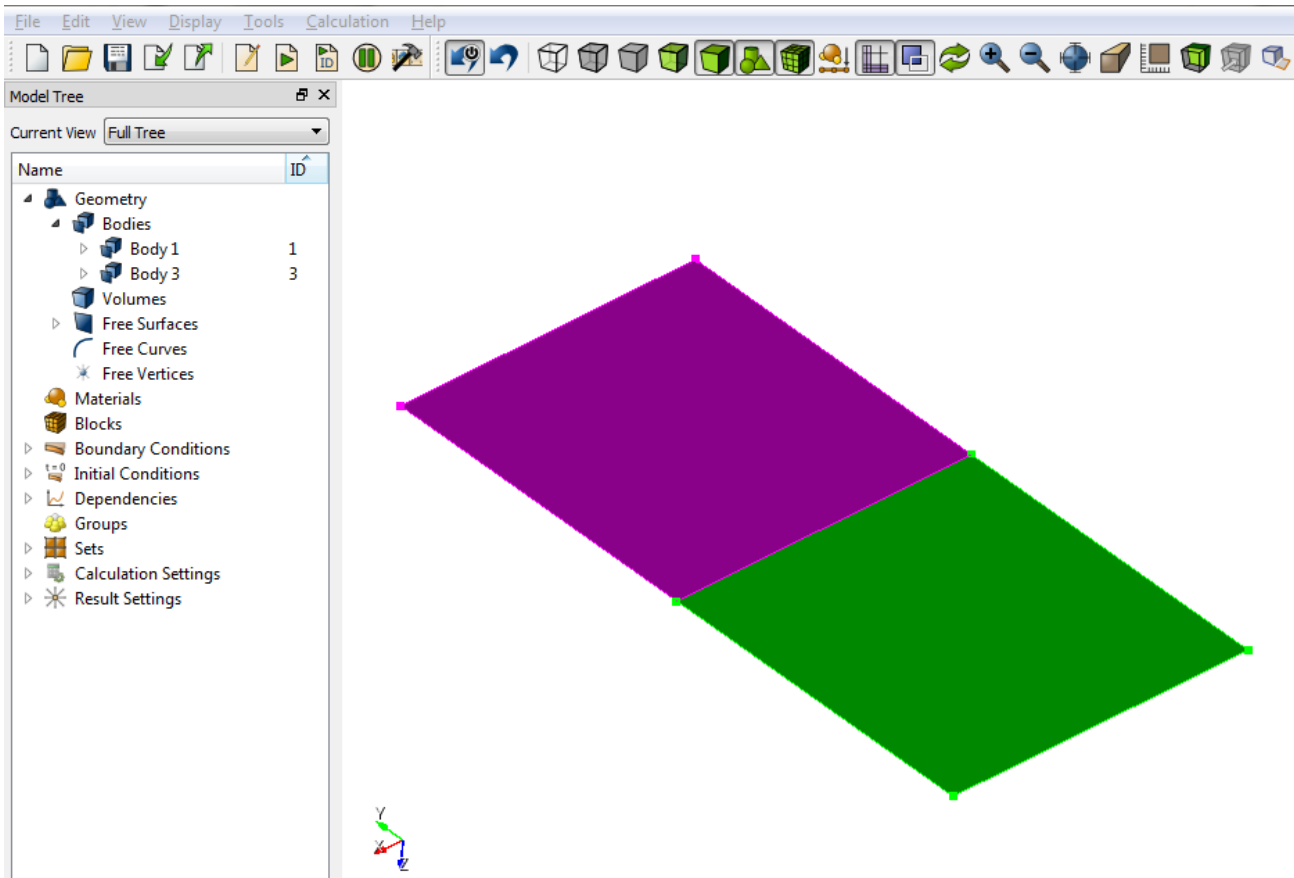

4. Print and splice the surface.

On the command panel, select the module for constructing volumetric geometry (Mode - **Geometry**, Entity - **Surface**, Action - **Imprint / Merge**). Set the following parameters:

- Surface ID(s): all.

Click **Apply**.

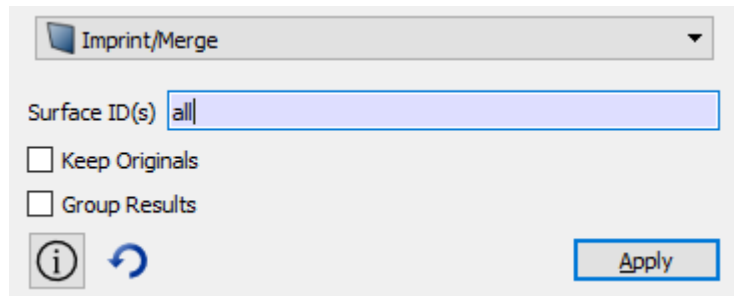

5. Break curve 11 into two parts.

On the command panel, select the module for constructing volumetric geometry (Mode - **Geometry**, Entity - **Curve**, Action - **Modify**). Set the following parameters:

- Split;
- Curve ID: 11;
- Split Method/Location: Distance;
- Value: 1000;
- Starting From: 10.

Click **Apply**.

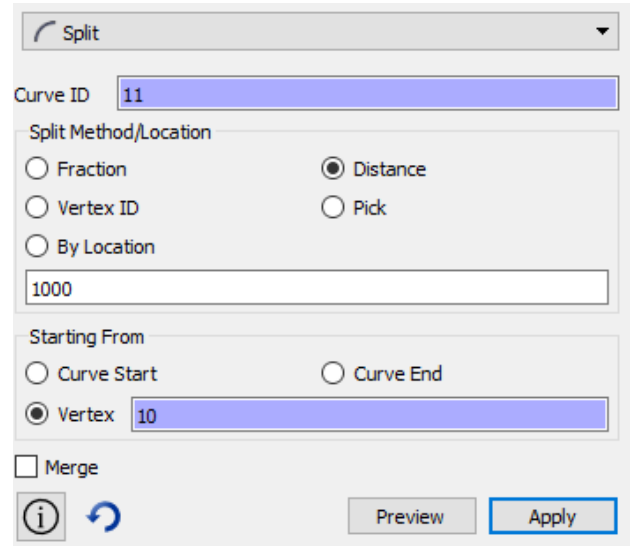

6. Write the following commands on the command line:

- imprint all;
- merge all.

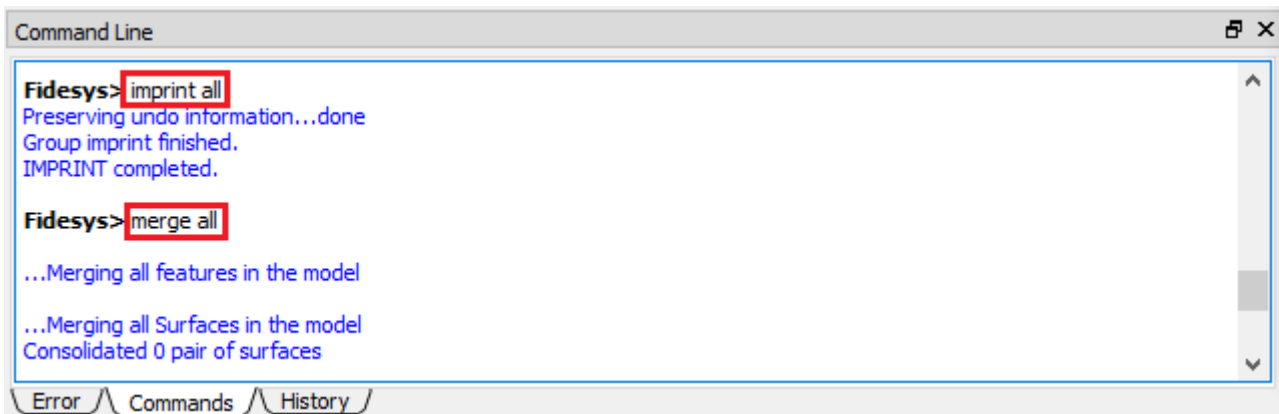

Meshing

1. On the command panel, select the curve meshing mode (Mode - **Mesh**, Entity - **Surface**, Action - **Intervals**). Specify the degree of refining mesh:

- Approximate Size;
- Select Surfaces: all;
- Approximate size: 250.

Click **Apply Size**.

Click **Mesh**.

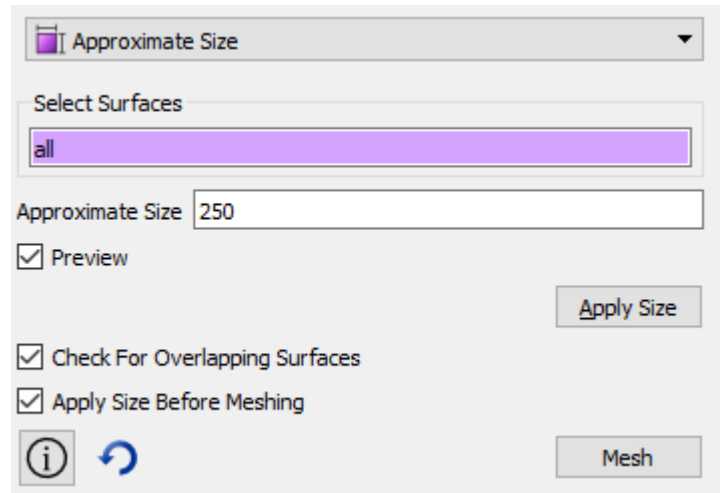

Specifying the material and type of item

1. On the command panel, select the mode for setting material properties (Mode - **Material**, Entity - **Materials Management**). From the Imported Material list, drag the Soil to the Material ID window.

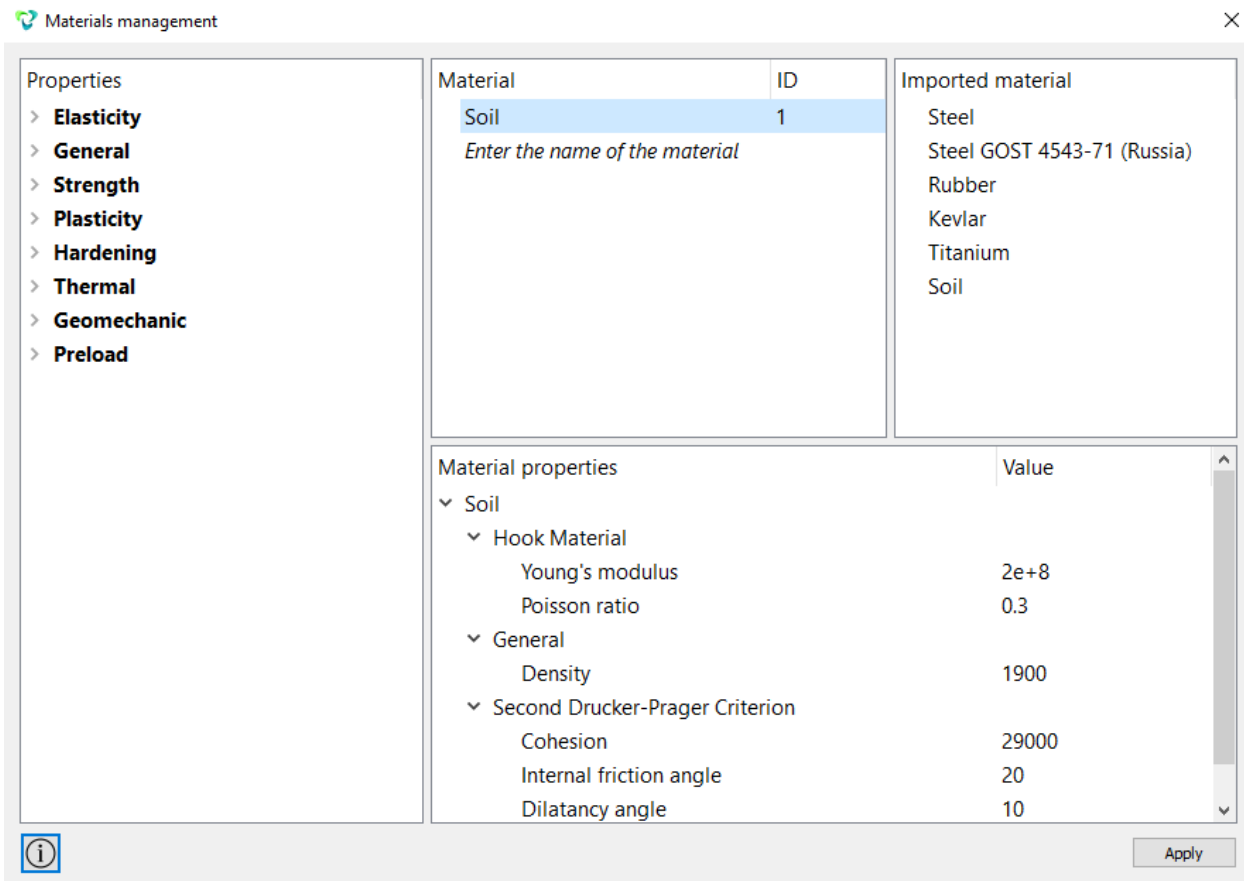

Click **Apply**.

2. Create a block of the one type of material.

On the command panel, select the mode for setting material properties (Mode - **Blocks**, Entity - **Block**, Action - **Add**). Set the following parameters:

- Block ID: all;
- Entity List: Surface;
- Entity ID(s): all.

Click **Apply**.

Block ID

Entity List

Entity ID(s)

3. Assign the material to the block.

On the command panel, select the module for setting material properties (Mode - **Blocks**, Entity - **Block**, Action - **Set Material**). Set the following parameters:

- Block ID(s): 1;
- Select the previously created material from the list: Soil.

Click **Apply**.

Block ID(s)

Available Materials

4. Assign an item type.

On the command panel, select the module for setting material properties (Mode - **Blocks**, Entity - **Block**, Action - **Element types**). Set the following parameters:

- Block ID (s): 1;
- Category: Plane;
- Order: 4.

Click **Apply**.

Block ID(s)

Category

Order

Setting boundary conditions

1. Fix curves 16 and 12 in the X direction.

On the command panel, select Mode - **Boundary Conditions**, Entity - **Displacement**, Action - **Create**. Set the following parameters:

- System Assigned ID;
- Entity List: Curve;
- Entity ID(s): 16 12 (separated by spaces);
- Degrees of Freedom: X-Translation Disp;
- DOF Value: 0.

Click **Apply**.

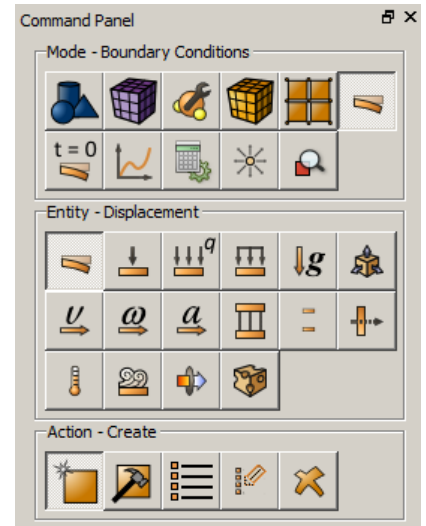

2. Set non-reflective boundary conditions.

On the command panel, select Mode - **Boundary conditions**, Entity - **Absorbing BC**, Action - **Create**. Set the following parameters:

- System Assigned ID;
- Entity List: Curve;
- Entity ID(s): 7 15 13 6 (separated by spaces).

Click **Apply**.

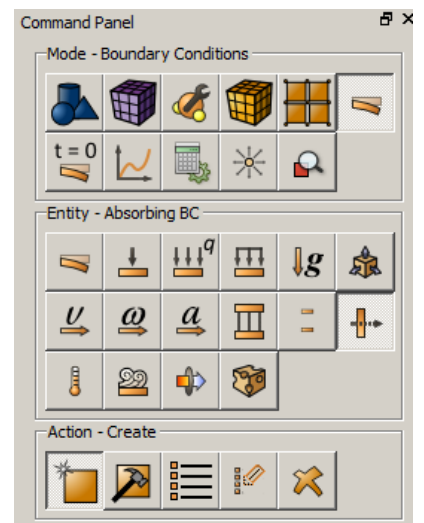

3. Set the force.

On the command panel, select Mode - **Boundary Conditions**, Entity - **Force**, Action - **Create**. Set the following parameters:

- System Assigned ID;
- Force Entity List: Vertex;
- Entity ID(s): 10;
- Direction: 0 -1 0 (space separated).

Click **Apply**.

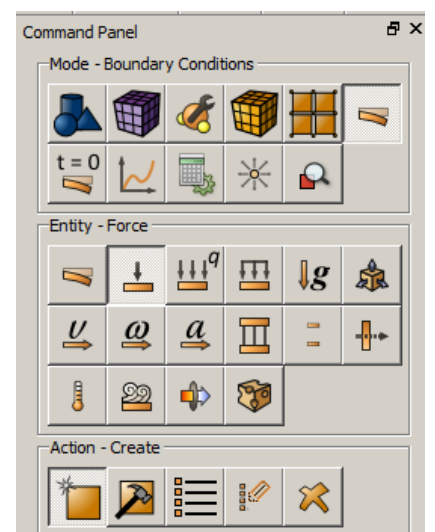

Set the BC dependency on time and / or coordinates

1. Create a formula 1 for strength 1.

On the command panel, select Mode – **BC Dependency**.

Click Forse 1 and choose Formula panel in the right. Then choose Berlage and set the following parameters:

- Select the flag Formula: Berlage;
- Amplitude: $2e8$;
- Frequency: 10.

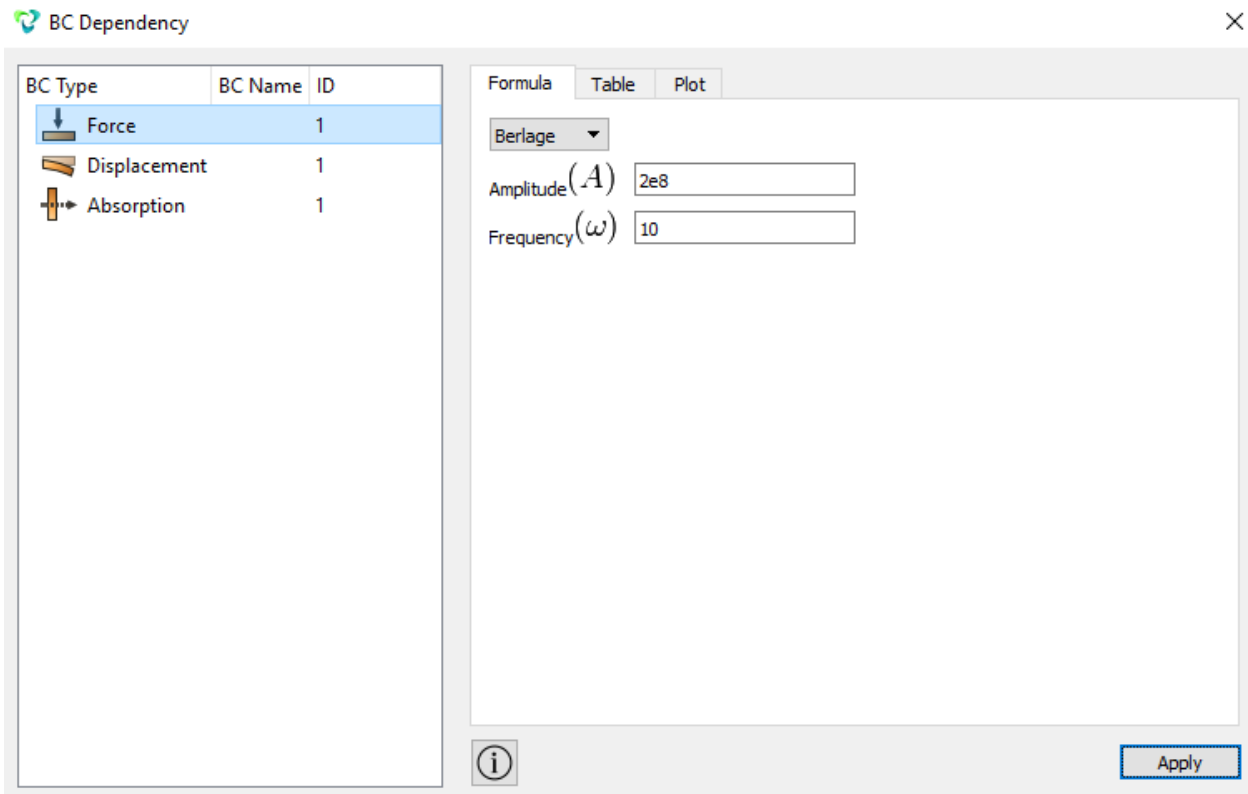

Click **Apply**.

Receivers

1. Create receivers on curve 17 along all directions.

On the command panel, select Mode - **Receivers**, Operation - **Create**. From the drop-down list, select the fields whose data you want to save in SEG-Y format. Set the following parameters:

- System assigned ID;
- Entity List: Curve;
- Entity ID(s): 17;
- Velocity;
- Variables: All.

Click **Apply**.

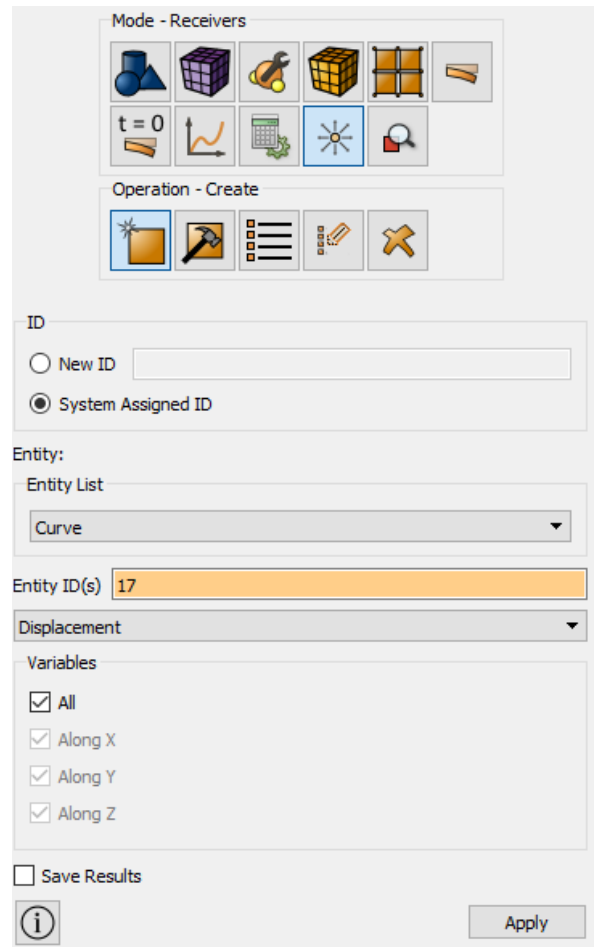

The receiver lines are highlighted on the model in yellow when clicked in the corresponding section of the Model Tree.

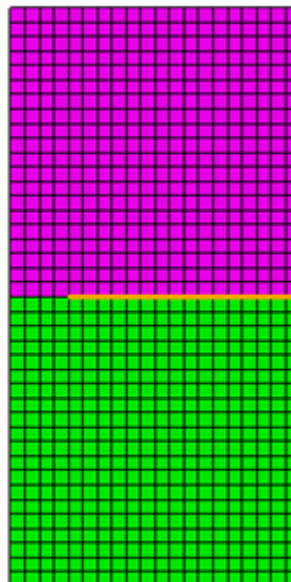
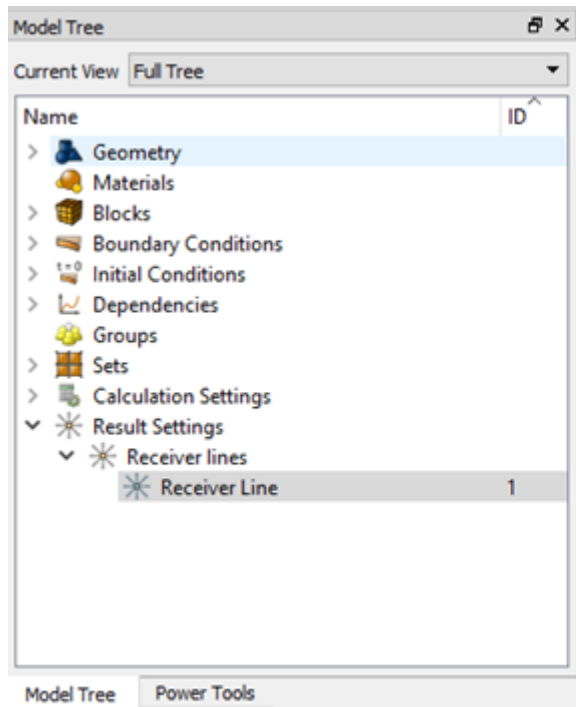

Run calculation

1. Set the type of task you want to solve. On the command panel, select the calculation settings mode (Mode - **Calculation Settings**, Calculation Settings - **Transient analysis**, Transient - **General**).

Set the following calculation parameters:

- Dimension: 2D;
- Method: Complete solution;
- Scheme: Explicit;
- Max time: 10;
- Max steps count: 10000;
- Preloaded model: uncheck;

Click **Apply**.

Go to the settings section for Output Fields. Specify:

- Save Results: Every 100 Steps

Click **Apply**. Click **Start Calculation**.

In the window that appears, select the directory in which the result will be saved, and enter the file name.

In case of a successful calculation, a message will be displayed in the console: "Calculation finished successfully at" date "" time "".

Command Panel

Mode - Calculation Settings

Calculation settings - Transient analysis

Transient - General

Dimensions: 2D

Plain state

Plane strain

Plane stress

Use MPI

Method: Full solution

Scheme: Explicit

Options

Max time: 10

Transient - Output Fields

Calculate nodal and reaction forces

Calculate kinetic and deformation energies

3D record

Output Material Properties

Save Results

Every: 100 steps

Every time interval: 0.3

Output maximum: 100 results

Results analysis

1. Open the file with the results. This can be done in three ways.

- Press Ctrl + E.
- From the main menu, select **Calculation** → **Results**. Click **Open Last Result**.

2. To analyze the results, go to the **Fidesys Viewer** window.

3. On the top bar, select the required result data to display. From the first drop-down list, select **Stress**, from the second - **Mises**.



4. Set the step 1 in the step viewer panel. You should see the plate image in the initial state. Next, click on Play . You should see the propagation of stress over time.

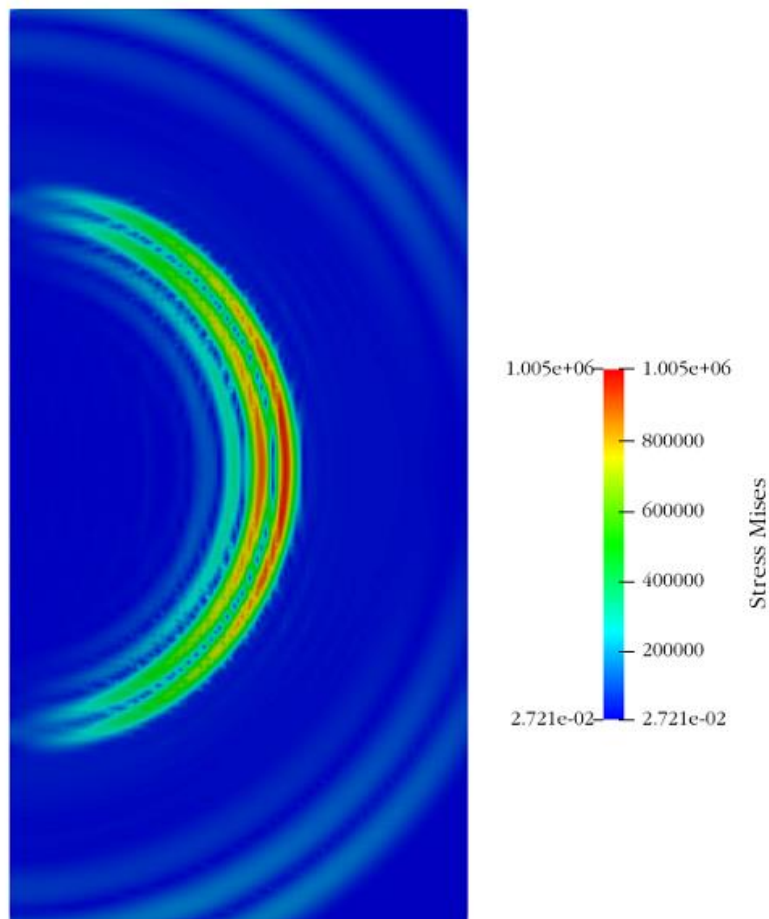

5. Open the saved data in SEG-Y format.

To do this, go to **Menu - File - Open**. In the drop-down list of file types, select SEG-Y Files (*.sgy, *.segy). Specify the file to view **test_Vy.sgs**

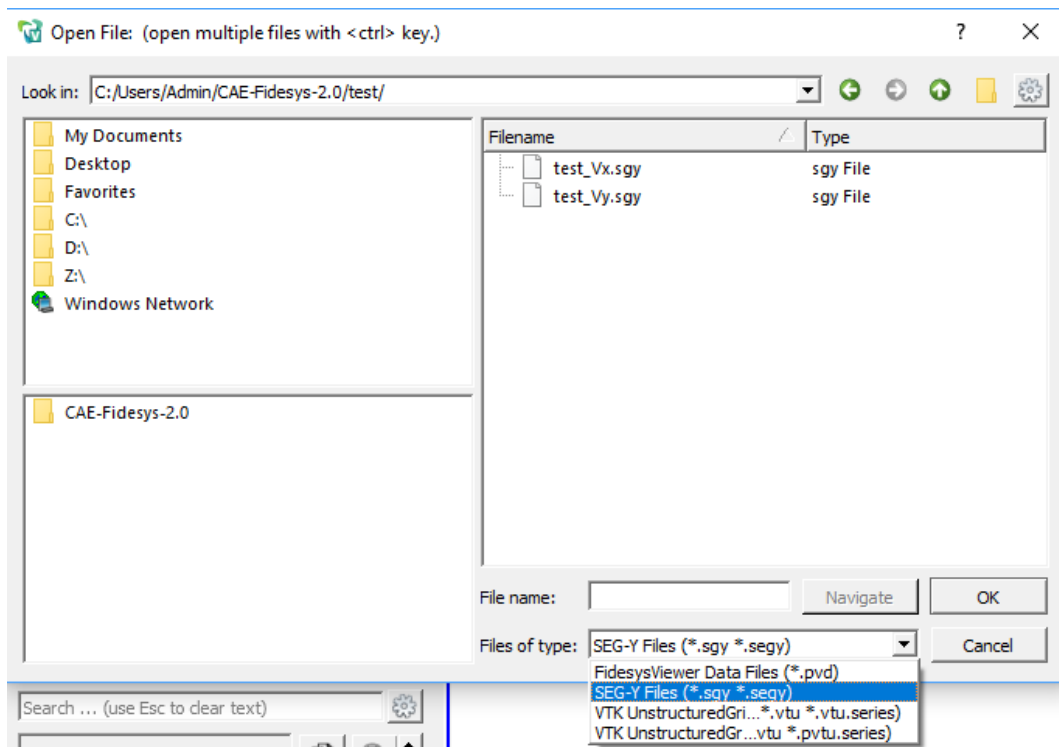

Set the viewing direction along the Y axis



The calculation results for speeds V_y in the SEG-Y format are visualized in the field of visualization.

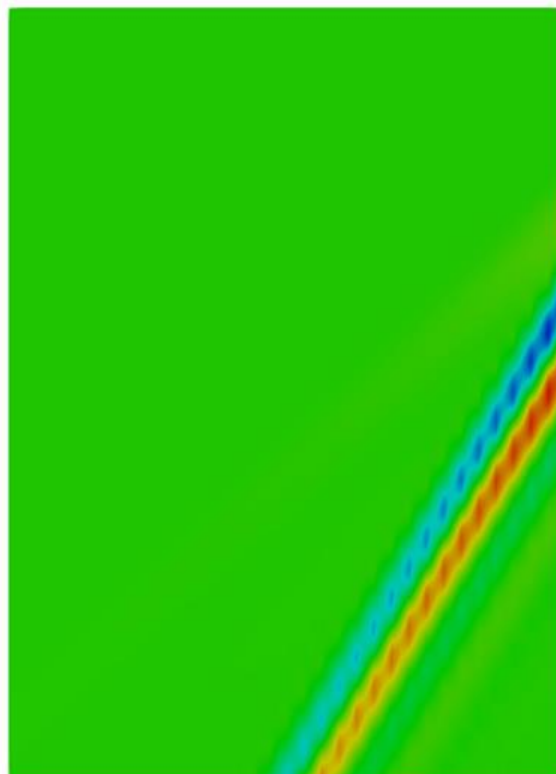

Using the console interface

Geometry creating, meshing, setting boundary conditions and materials can be performed using the console interface. Below is the program code that allows you to perform the steps of the above manual, you only need to **specify the full path and name of the saved file.**

```
reset
create surface rectangle width 10000 zplane
webcut body 1 with plane xplane offset 0
webcut body 1 with plane yplane offset 0
delete Surface 3
imprint all
merge all
split curve 11 distance 1000 from vertex 10
imprint all
merge all
surface all size 250
mesh surface all
create material 1 from 'Soil'
block all add surface all
block 1 add surface all
block 1 material 1
block 1 element plane order 4
create displacement on curve 16 12 dof 1 fix
create absorption on curve 7 15 13 6
create force on vertex 10 force value 1 direction 0 -1 0
bcdep force 1 value 'berlage(2e+8, 10, time)'
create receiver on curve 17 displacement 1 1 1
create receiver on curve 17 velocity 1 1 1
create receiver on curve 17 principalstress 1 1 1
create receiver on curve 17 pressure
output nodalforce off energy off record3d on log on vtu on material off results everystep
100
analysis type dynamic elasticity dim2 planestrain preload off
dynamic method full_solution scheme explicit maxtime 10 maxsteps 10000
calculation start path 'D:\Fidesys\test.pvd'
```



Contacts

<http://www.cae-fidesys.com>

support@cae-fidesys.com

[+7\(495\) 177-36-18](tel:+7(495)177-36-18)